



QUICK SHIP  
PRODUCTS  
2026/1

GLAS  
ITALIA

QUICK SHIP  
PRODUCTS

**TAVOLI  
CONSOLLE  
SCRITTOI**

10  
ATLANTIS



12  
BISEL



18  
DOBLE



24  
FOUNTAIN



66  
THE 5 O'CLOCK LIE



72  
XX



28  
GLASS TABLE 1976



30  
HAROLD AND MAUDE



32  
ILLUSION



34  
L.A. SUNSET



**CONTENITORI**

76  
COMMODORE



80  
OLTRALPE



84  
ROBOTIN



38  
NACRE



42  
OSCAR



44  
PIRANDELLO



46  
REMIS



**SPECCHI**

92  
BRIC



94  
CELESTE



98  
CONTRO PESO



102  
FICTION



52  
SEASONS



54  
SHIMMER



60  
TERRALIQUIDA



62  
THE DARK SIDE OF  
THE MOON



104  
GLI SPECCHI DI DIONISO



114  
I MIRROR



118  
KOOH-I-NOOR



120  
MAESTRALE



124  
**MARLENE**



130  
**MENTEUR**

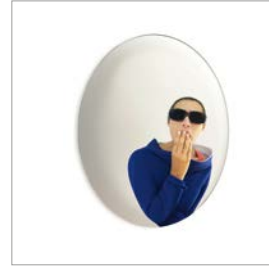

136  
**SCRIBBLE**



142  
**SPECCHI SHIMMER**



146  
**STURM UND DRANG**



**COMPLEMENTI**

152  
**ANGELO E ANGELA**



154  
**TELEGRAFO**



156  
**TRANSFORMER**



158  
**TUTUBE**



**SEDUTE**

162  
**BENT GLASS BENCH  
BENT GLASS STOOL**



166  
**CRYSTAL STOOL**

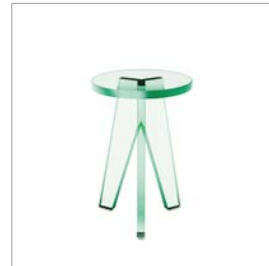

**TAVOLI  
CONSOLLE  
SCRITTOI**

---

## ATLANTIS TAVOLI BASSI

Lorenzo Arosio

**Serie di tavoli bassi realizzati incollando lastre di cristallo 6 mm temperato, tagliato a getto d'acqua e molato a 45°. Disponibili in cristallo trasparente extralight o laccato lucido. La purezza formale, la sobrietà e le sofisticate tecniche di lavorazione sono le caratteristiche principali di questo tavolo.**

Series of low tables obtained by gluing 6 mm thick tempered glass plates, cut with water jet and with 45° chamfered edge. Available in extralight transparent glass or glossy lacquered. The formal purity, the sobriety and the sophisticated craftsmanship are the principal characteristics of this table.

**dimensioni disponibili** / available dimensions

• L110 - P110 - H36

**finiture disponibili** / available finishes

Cristallo trasparente extralight /  
Transparent extralight glass



TAT08

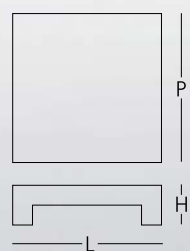

L110 - P110 - H36



## BISEL

Patricia Urquiola

13

**Collezione composta da tavoli alti, tavoli bassi e consolle, realizzati in cristallo multistrato e multi-cromatico, ottenuto stratificando cinque lastre di cristallo extrachiaro 5 mm con pellicole di diversi colori. Le lastre ottenute vengono sagomate in diverse forme, molate filo lucido e sfaccettate grazie ad importanti bisellature che fanno emergere in trasparenza le meravigliose e variegiate colorazioni del materiale. I vari componenti vengono poi saldati tra di loro in totale purezza, grazie a speciali tecniche di incollaggio, dando forma così a preziosissimi gioielli d'arredo. Disponibili nelle finiture verde o ocra.**

Collection of high tables, low tables and console, made in multi-layered and multichromatic glass, created by laminating five slabs of 5mm extralight glass each with a different coloured film. The obtained glass sheets are in different shapes, shiny ground polished and "faceted" by means of unique bevels accentuating through the transparency of the glass the stunning multicoloured material. The different components are then welded together in total clarity, by means of a special gluing technique, so creating very precious "furniture jewels". Available in green or ocher finish.

### dimensioni disponibili / available dimensions

- L100 - P91 - H40
- L60 - P35 - H50
- L119 - P42 - H80

### finiture disponibili / available finishes

- Ocra / Ocher
- Verde / Green

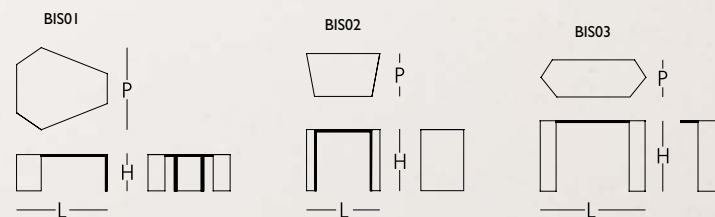
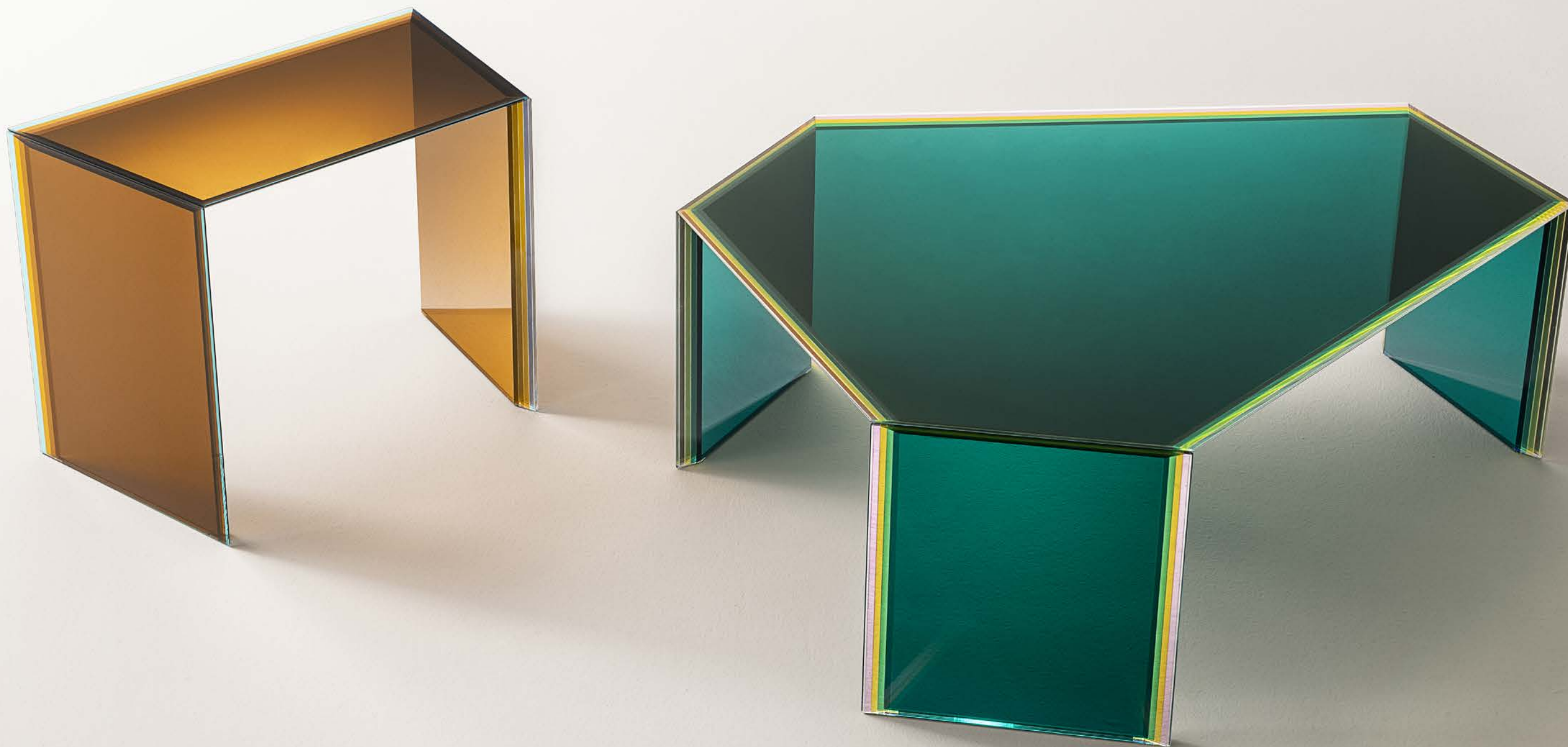

BIS01 L100 - P91 - H40 BIS02 L60 - P35 - H50 BIS03 L119 - P42 - H80

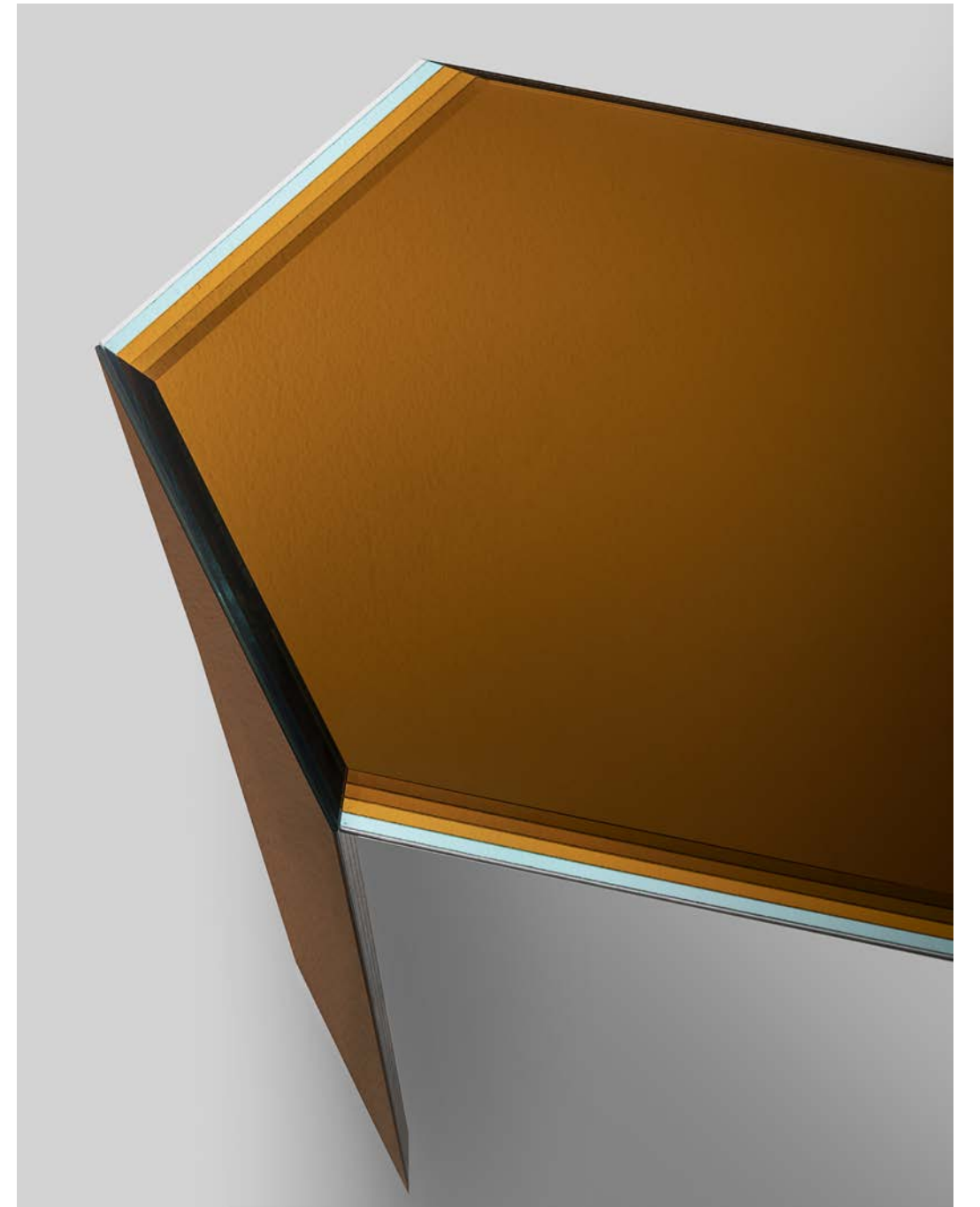

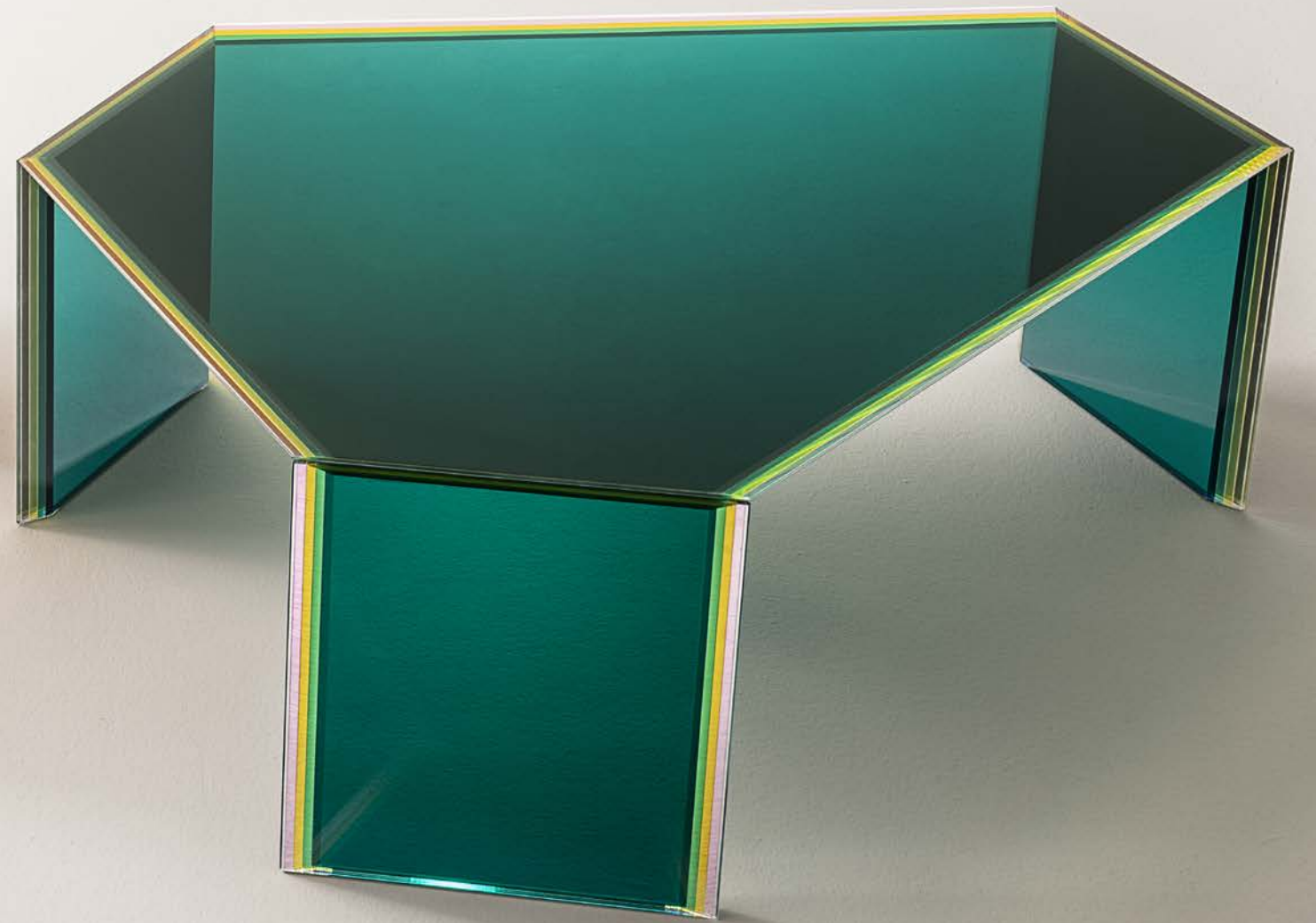
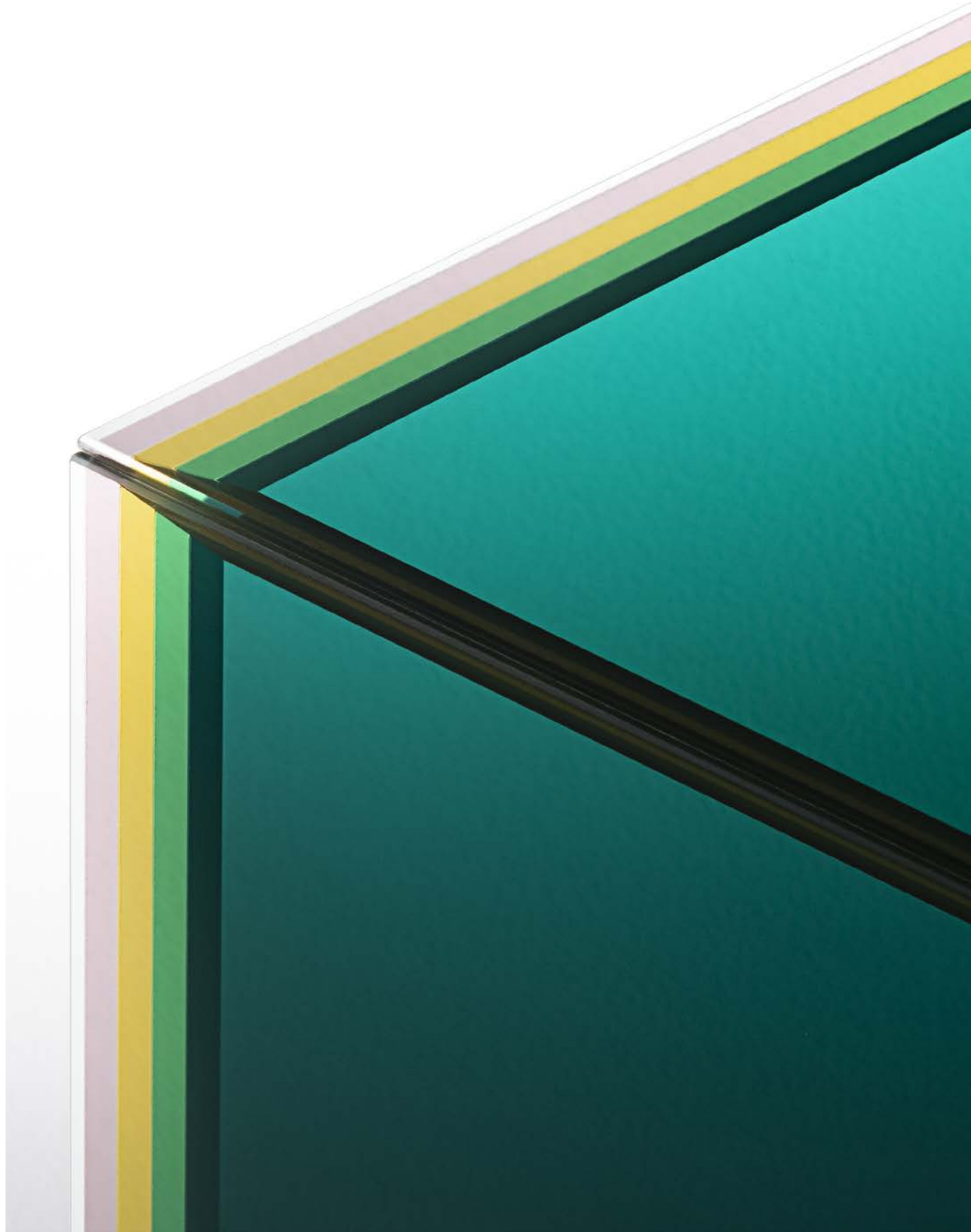

## DOBLE

Patricia Urquiola

19

**Collezione di tavoli bassi e consolle realizzati in un innovativo cristallo stratificato e incollato, che dà vita a straordinarie illusioni ottiche e meravigliosi effetti surreali.**

**Gli oggetti osservati attraverso questo materiale, infatti, sembrano mutare la loro consistenza materica, variare la loro posizione, dimensione e quantità.**

**La base, in specchio stratificato, riflette ed amplifica questi magici effetti.**

Collection of low tables and consoles made of an innovative laminated and glued glass, which gives life to extraordinary optical illusions and wonderful surreal effects.

The objects observed through this material, in fact, seem to change their material consistency, vary their position, size and quantity.

The base, in laminated mirror, reflects and amplifies these magical effects.

**dimensioni disponibili / available dimensions**

- Ø47 - H50
- L100 - P42 - H80



DOL01



DOL07

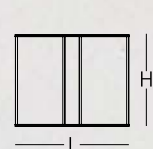
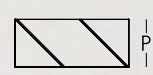

DOL01 Ø47 - H50 DOL07 L100 - P42 - H80





## FOUNTAIN

Tokujin Yoshioka

**Tavoli bassi rotondi di grande preziosità e poesia, con base in cristallo di Murano colato, modellato e cesellato a mano secondo sapienti tecniche di lavorazione. Il piano, anch'esso in cristallo colato, è inserito in appoggio all'interno della base.**

**Questi oggetti riproducono la poesia dell'acqua che sgorga da una fonte, con tutte le sue irregolari increspature e i vibranti scintillii.**

Precious and poetic round low tables with Murano poured glass bases, hand shaped and chiseled by highly-tuned processing techniques. The top is also in poured glass and is inserted resting inside the base. These objects reproduce the poetry of water flowing from a spring with all its changing rivulets and glittering sparkle.

dimensioni disponibili / available dimensions

- Ø38 - H42
- Ø45 - H33
- Ø65 - H21

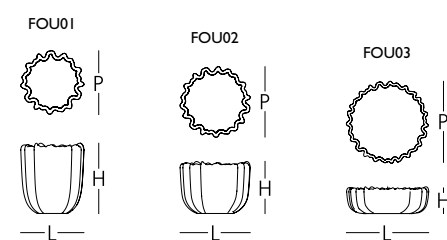

FOU01 Ø38 - H42 FOU02 L Ø45 - H33 FOU03 L Ø65 - H21





## GLASS TABLE 1976

Shiro Kuramata

**Tavolo basso dal raffinatissimo aspetto minimale con gambe in cristallo trasparente 24 mm termosaldate ad un piano in cristallo trasparente 12 mm temperato. Prodotto storico ed iconico del design internazionale, disegnato dal grande maestro Shiro Kuramata nel 1976.**

Low table characterised by the very refined minimal aspect with feet in 24 mm thick transparent glass thermo-welded to a top in 12 mm transparent tempered glass. Historical and iconic product of the international design, designed in 1976 by the great master Shiro Kuramata.

**dimensioni disponibili / available dimensions**

• L120 - P120 - H38

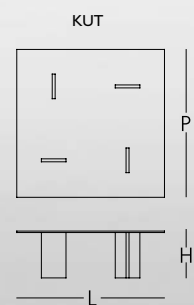

KUT L120 - P120 - H38

## HAROLD AND MAUDE

Carlo Tamborini

**Tavolini in cristallo trasparente extrachiaro, disponibili in due misure differenti. Una complessa ed innovativa curvatura, caratterizzata da angoli ed inclinazioni molto ardite, conferisce ai tavolini grande dinamismo e plasticità. Questo virtuosismo tecnico dona al tavolino un aspetto di estrema leggerezza.**

Low tables in transparent extralight glass, available in two different sizes. A complex and innovative curvature, characterized by particularly daring angles and gradients, confers great dynamism and plasticity to the low tables. This technical virtuosity gives the low table an extremely light appearance.

**dimensioni disponibili / available dimensions**

- L58 - P58 - H33
- L50 - P50 - H57



HAR01/ HAR02

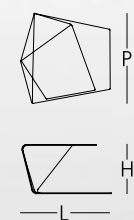

HAR01 L58 - P58 - H33 HAR02 L50 - P50 - H57

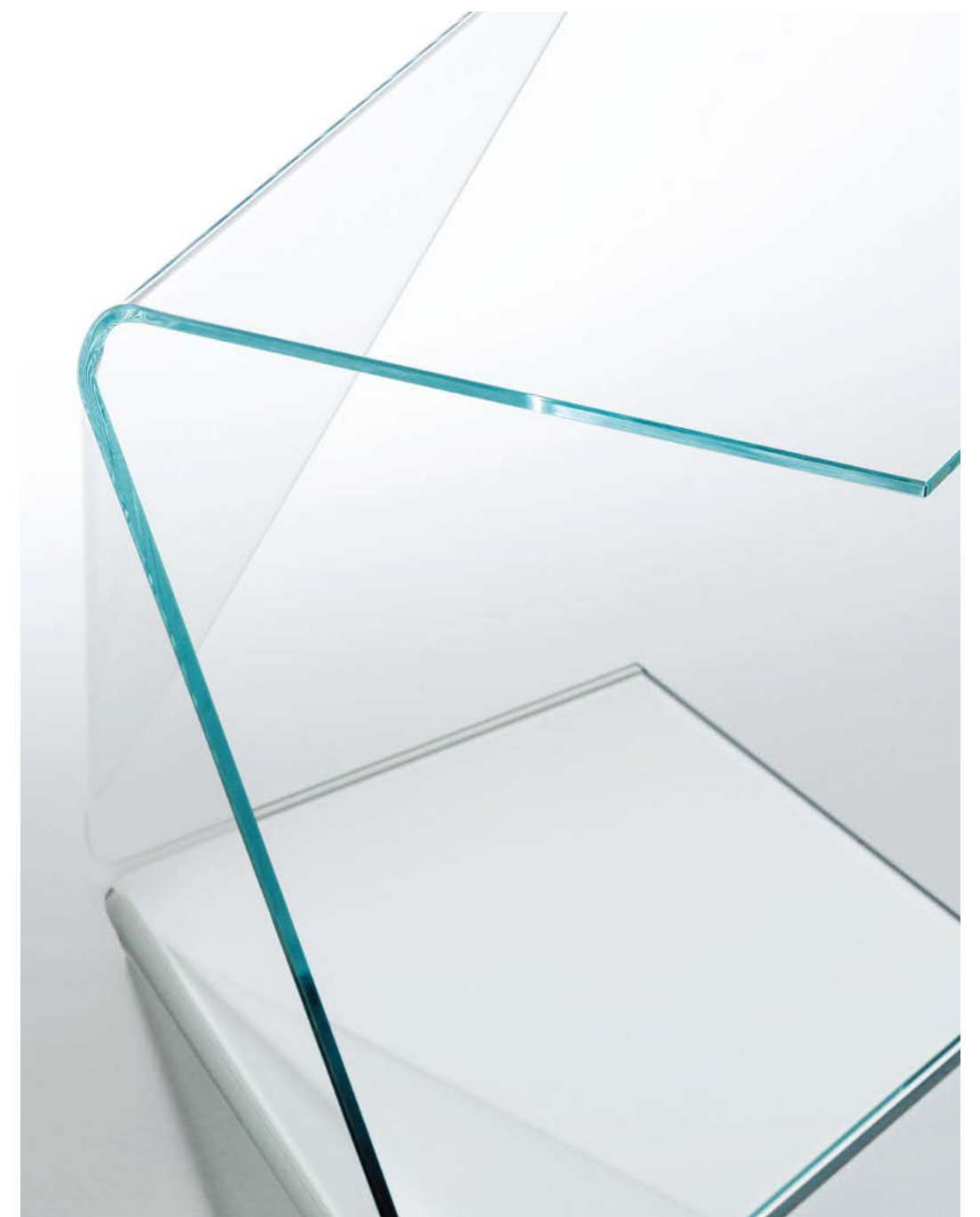

# ILLUSION

Jean-Marie Massaud

**Serie di tavoli bassi a forma di parallelepipedo con piano con finitura a specchio e fianchi a specchio sfumato digradante. Realizzati in cristallo extralight incollato a 45°.**

Series of parallelepiped shaped low tables with mirroring top and degrading shading mirroring sides. Realized in extralight glass, glued at 45°.

**dimensioni disponibili / available dimensions**

- L40 - P40 - H40
- L40 - P40 - H60
- L39 - P39 - H80
- L110 - P110 - H3
- L70 - P70 - H33

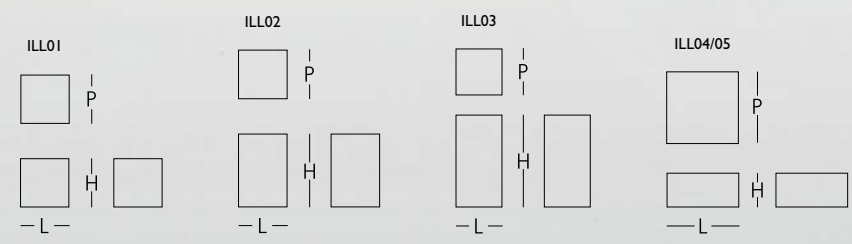

ILL01 L40 - P40 - H40 ILL02 L40 - P40 - H60 ILL03 L39 - P39 - H80 ILL04 L110 - P110 - H3 ILL05 L70 - P70 - H33



## L.A. SUNSET

Patricia Urquiola

**Tavoli bassi di forma rotonda con struttura in tubo metallico verniciato nei colori blu notte o rame in una speciale finitura metallizzata opaca.**

**Il piano, in vetro stratificato, è una tavolozza di colori su un fondo a specchio, che sfumano e si fondono tra loro come gas o fluidi, dissimulando lo stato solido della materia. Il fondo a specchio conferisce una particolare energia e luminosità a questa nuance di colori.**

Low round tables with tubular metal structure painted midnight blue or copper colour in a special metallic opaque finish.

The top, in laminated glass, is a palette of colours on a mirrored background, blending and mixing with one another like gas or fluids, disguising the solid state of the material.

The mirrored background lends a particular energy and brightness to these colour tones.

**dimensioni disponibili / available dimensions**

- Ø79 - H40
- Ø94 - H35

**finiture disponibili / available finishes**

Blu notte / Midnight blue

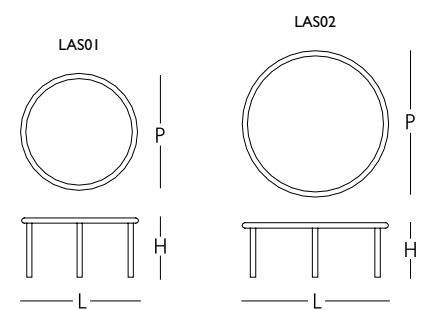

LAS01 Ø79 - H40 LAS02 Ø94 - H35





## NACRE

Yabu Pushelberg

39

**Nacre è un tavolo basso dall'aspetto fluido che trae ispirazione dalla forma organica di una conchiglia d'ostrica.**

**La base è costituita da una vasca ovale in cristallo trasparente extralight con fondo a specchio, ottenuta deformando con un complesso processo termico una lastra piana da 12 mm e rifilandola perimetralmente.**

**Il top, in appoggio sulla vasca, è in vetro stratificato 6+6 mm con finitura a specchio extralight che sfuma in maniera circolare, definendo un'area trasparente di forma rotonda.**

**Il top è disponibile anche con un foro, in corrispondenza dell'area trasparente, attraverso il quale si ha accesso all'interno della vasca, per poterla utilizzare come fioriera, terrario o contenitore-espositore di oggetti.**

Nacre is a low table with a fluid aspect inspired by the organic form of an oyster shell.

The base, made up of an oval basin in transparent extralight glass with mirrored bottom, is created by moulding a flat slab of 12 mm glass through a complex heat treatment and trimming the perimeter to shape.

The top, placed on the basin, is in laminated glass 6+6 mm in extralight mirror finish which fades in a circular way, emphasizing the transparent round area.

The top is also available with an opening next to the transparent area, through which you can access the inside of the basin, and use it as flower box, terrarium (planter) or storage/display unit.

**dimensioni disponibili / available dimensions**

• L128 - P92 - H37 (con foro - with hole)

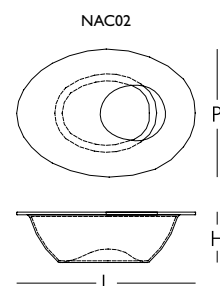

NAC02 (con foro - with hole) L128 - P92 - H37



## OSCAR

Piero Lissoni

**Tavolo in cristallo trasparente extralight dall'estrema leggerezza e pulizia formale. La base molto esile, nonostante un'apparenza di fragilità e delicatezza, è solida e resistente grazie ad uno speciale trattamento del cristallo. Il piano, in cristallo temperato, va in appoggio sulla base.**

Table in transparent extralight glass characterised by extreme lightness and formal cleanness. The very slender base, despite an apparent fragility and fineness, is solid and resistant thanks to a special treatment of the glass. The top, in tempered glass, rests on the base.

**dimensioni disponibili / available dimensions**

- L220 - P90 - H74
- L140 - P140 - H74

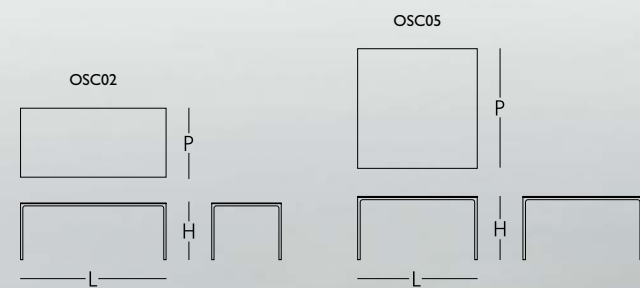

OSC02 L140 - P140 - H74 OSC05 L220 - P90 - H74



## PIRANDELLO

Jasper Morrison

45

**Scrittoio in cristallo trasparente extralight, temperato e termosaldato, disponibile in due diverse misure. Disponibile con la barra poggipiedi in legno di frassino naturale. La grande cura dei dettagli e le calibrate proporzioni conferiscono un aspetto di delicata armonia.**

Writing desk in transparent extralight glass tempered and thermo-welded. Available in two different sizes. Available with the footrest bar in natural ash. The great care of the details and the balanced proportions endow an appearance of delicate harmony.

**dimensioni disponibili / available dimensions**

- L110 - P49 - H83
- L80 - P49 - H83



PIR01/02

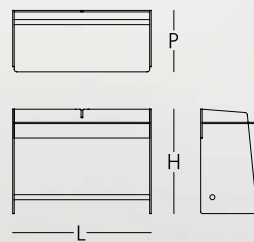

PIR01 L110 - P49 - H83 PIR02 L80 - P49 - H83



< INDEX

## REMIS

Patricia Urquiola

47

**Collezione composta da un tavolo basso e da una consolle con una struttura in legno completamente rivestita da un mosaico di piastrelle in vetro colato dalle colorazioni variegata e irregolari. Le piastrelle sono sagomate e posizionate in modo che il piano riproduca la proiezione assonometrica di un parallelepipedo. I pezzi sono completati da dei funzionali cassetti invisibili con sistema di apertura push-pull.**

Collection composed by a low table and a console with a wooden structure completely covered by a mosaic of cast glass tiles in various and random colours. The tiles are shaped and positioned so that the surface reproduces the axonometric projection of a parallelepiped element. The pieces are completed by functional invisible drawers with a push-pull opening system.

**dimensioni disponibili / available dimensions**

- L100 - P80 - H32
- L120 - P44 - H85

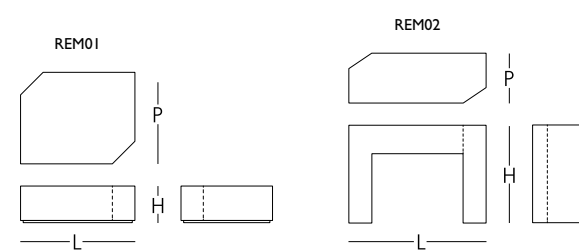

REM01 L 100 - P 80 - H 32    REM02 L 120 - P 44 - H 85





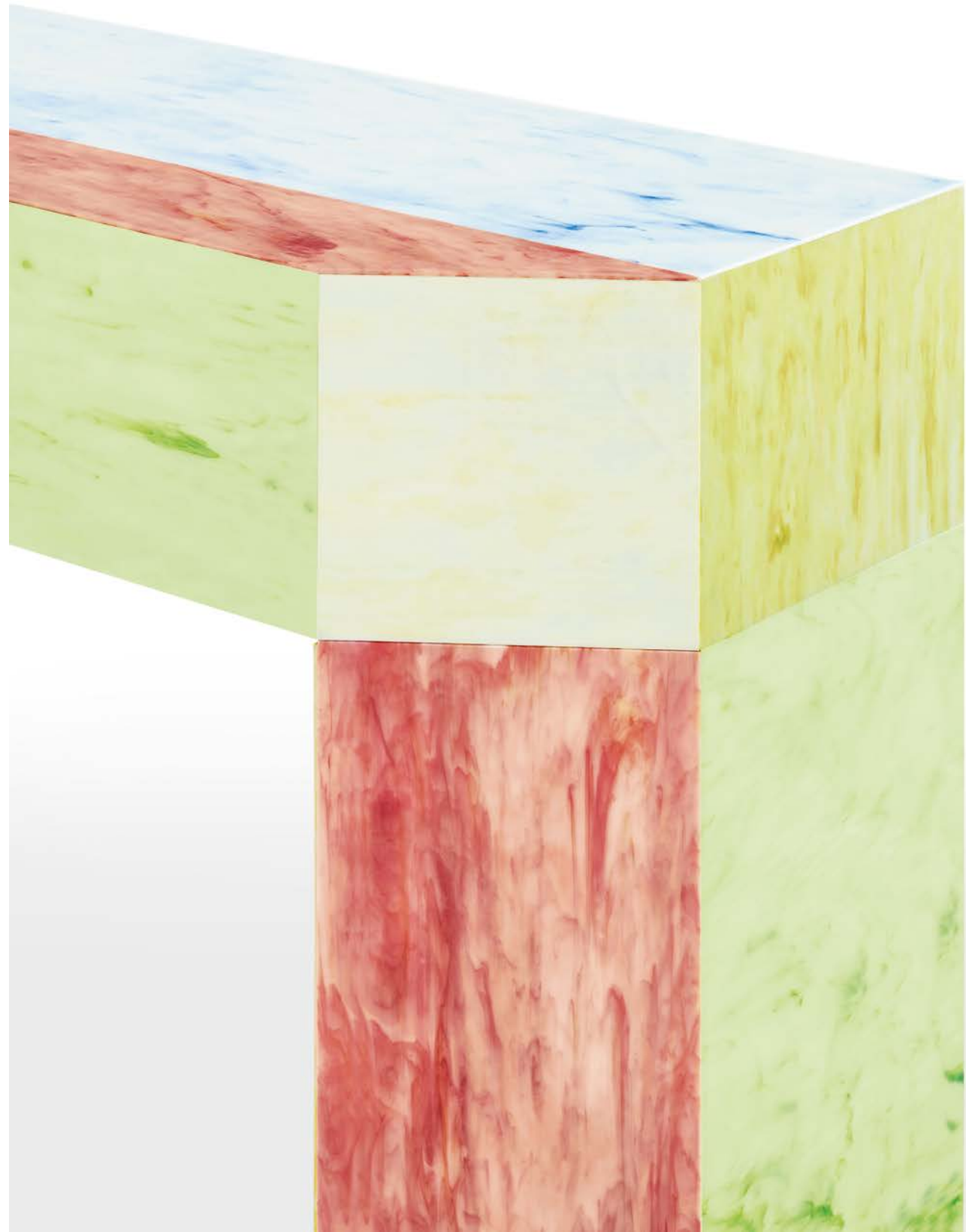

## SEASONS

Jean-Marie Massaud

**Tavolo basso realizzato completamente in cristallo trasparente extralight, temperato e incollato, con al centro una vasca di contenimento.**

**Il doppio piano permette di alloggiare all'interno del tavolino oggetti di vario genere, mentre la vasca, grazie ad un incollaggio che garantisce la tenuta dell'acqua, può essere utilizzata come vaso, fioriera o acquario. È disponibile anche una versione con bruciatore in acciaio inox alimentato da bioetanolo.**

Low table realized completely in tempered and glued transparent extralight glass. A retaining basin is placed in the centre. The double top allows various objects to be placed inside the low table, whilst the basin, which is watertight through a special gluing, can be used as vase, flower box or aquarium. A version with a burner in steel inox fuelled by bioethanol is also available.

dimensioni disponibili / available dimensions

• L120 - P120 - H33

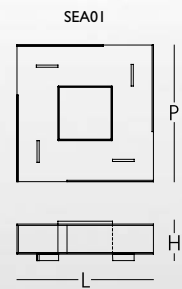

SEA01 L120 - P120 - H33



## SHIMMER TAVOLI

Patricia Urquiola

**Tavoli alti, bassi e consolle in cristallo stratificato e incollato, con una speciale finitura multicromatica cangiante, la cui colorazione varia in funzione dell'angolo di incidenza della luce e del punto di osservazione. Ne risultano oggetti dall'aspetto magico ed etereo. Per i codici da SHI01 a SHI07 le gambe sono incollate al piano, mentre nei tavoli alti sono smontabili e vengono fissate ai piani tramite piastre metalliche, dissimulate da decori circolari con finitura coprente. Per i codici da SHI14 a SHI26 il piano è in appoggio sulla base. Nella consolle SHI23 è inoltre fissato alla parete con dei fermi metallici.**

High tables, low tables and consoles in laminated and glued glass, characterized by a special iridescent multichromatic finish; the nuance varies according to the angle of the light source and the vantage point. Reflected objects with a magical and ethereal appearance emerge. For the codes from SHI01 to SHI07 the legs are glued to the top, while in the high tables they are removable. The high tables bases can be dismantled and are fixed to the top by means of metal plates, concealed by a circular decorated covering. For the codes from SHI14 to SHI26 the top rests on the base. In the SHI23 console it is also fixed to the wall with metal brackets.

dimensioni disponibili / available dimensions

- Ø52 - H45
- Ø65 - H50
- L120 - P65 - H35
- L100 - P45 - H84,5

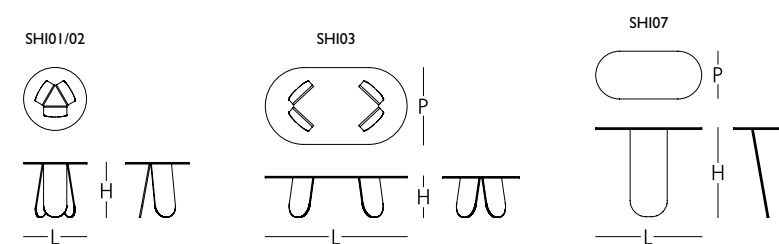

SHI01 Ø52 - H45 SHI02 Ø65 - H50 SHI03 L120 - P65 - H35 SHI07 L100 - P45 - H84,5







## TERRALIQUIDA

Claudio Silvestrin

**Tavolo basso composto da un parallelepipedo in pietra Limestone di aspetto monolitico e un elemento in cristallo trasparente extralight 15 mm temperato, incollato a 45°, che va in appoggio sullo stesso.**

**Il parallelepipedo in pietra ha i fianchi con finitura a spacco, mentre il piano è fiammato. La matericità, la gravità e la solidità della pietra si incontrano con la leggerezza, la purezza e l'etereità del cristallo.**

Low table composed of parallelepiped Limestone with a monolithic appearance and an element in tempered 15 mm thick glued 45° transparent extralight glass that rests on it.

The stone parallelepiped has the sides in a split-face finish, whereas the top is flamed. The materiality, the gravity and the solidity of the stone juxtapose the lightness, the purity and the ethereality of the glass.

dimensioni disponibili / available dimensions

• L185 - P100 - H23



TERLO1



TERLO1 L185 - P100 - H23



## THE DARK SIDE OF THE MOON

Piero Lissoni

**Tavolo basso a ponte in cristallo extralight stratificato con una sofisticata tecnica di lavorazione grazie alla quale il piano e i fianchi sono caratterizzati da una finitura multicromatica. Disponibile in due versioni: una a strisce, l'altra a tinte sfumate.**

Low table with bridge shape in laminated transparent extralight glass with sophisticated and innovative technical process, thanks to which the top and the sides are characterized by a multicoloured finish. Available in two versions: one is striped, and the other one with faded colours.

**dimensioni disponibili / available dimensions**

• L155 - P55 - H30

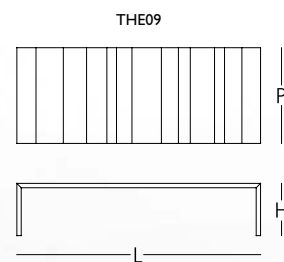
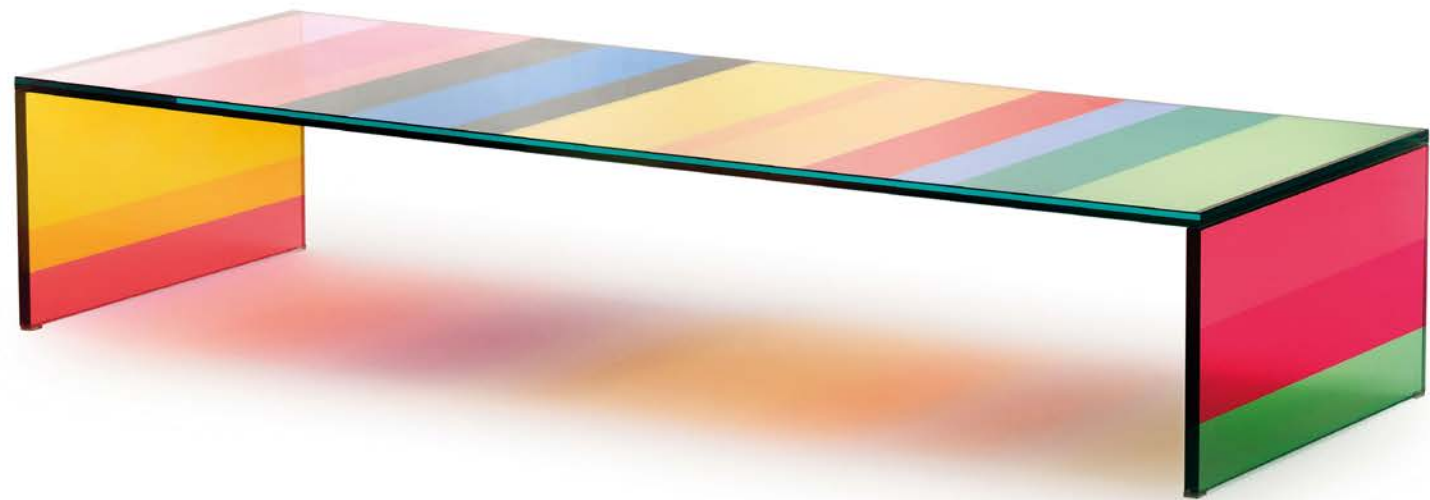

THE09 L155 - P55 - H30

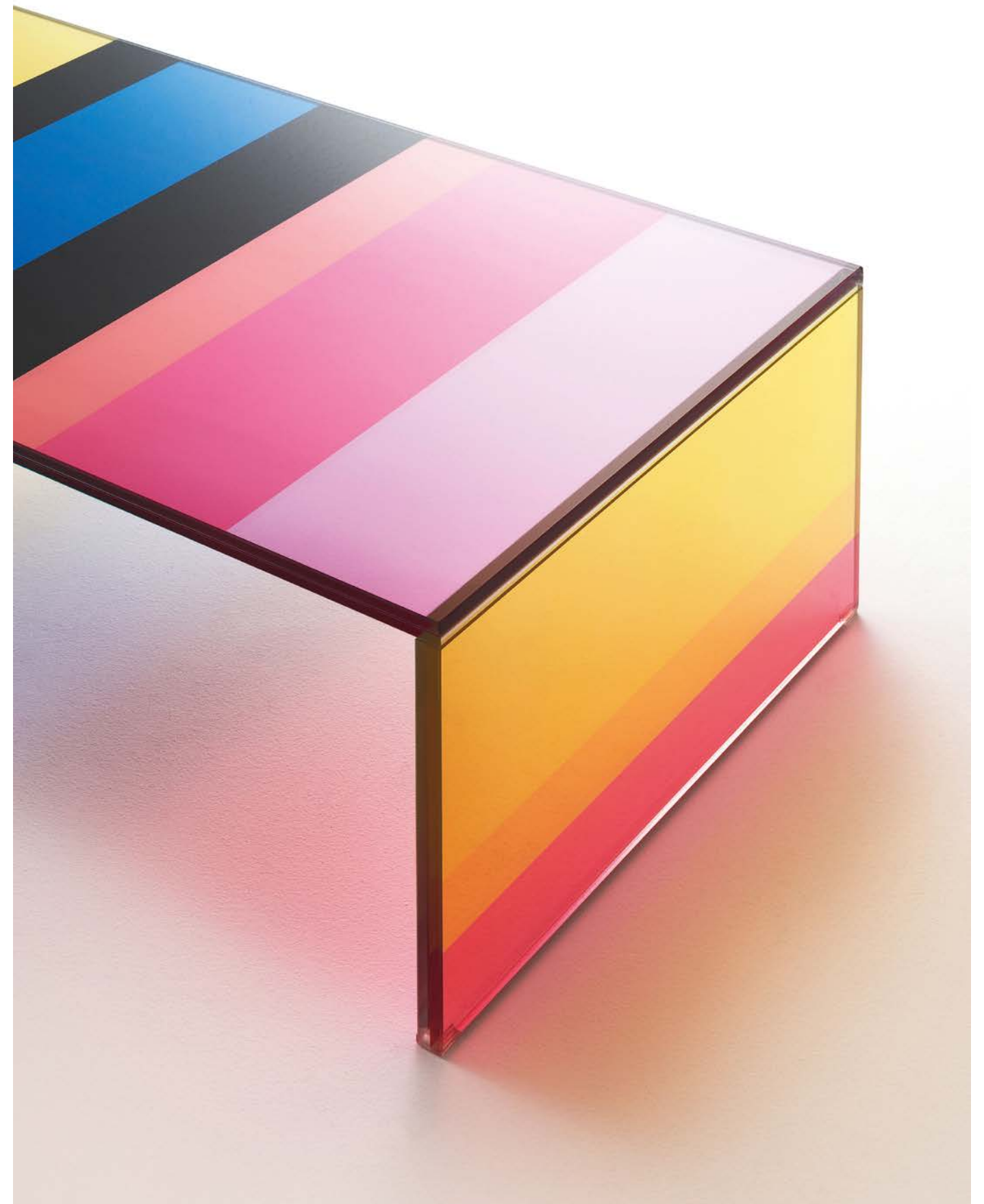



## THE 5 O'CLOCK LIE

Philippe Starck

67

**Tavoli bassi in cristallo bronzo o extrachiaro 8 mm, che, grazie ad innovative e complesse tecniche di lavorazione, è curvato su tutto il perimetro e argentato manualmente a regola d'arte. Si ottengono così dei piani in specchio con un bordo rialzato che riflette le immagini distorcendole in maniera inaspettata, mentre la superficie al centro rimane perfettamente piana, con un riflesso fedele. Le gambe, leggermente inclinate, e la struttura portante sono in acciaio con finitura nickel (per il piano in specchio extrachiaro) o bronzo (per il piano in specchio bronzo), ottenuta tramite trattamento galvanico. Disponibili in due formati, con altezze differenti.**

Low tables in bronze or extra clear 8 mm glass which, thanks to innovative and complex manufacturing techniques, is curved along the perimeter and perfectly manually silvered. In this way you create mirror tops with a raised edge giving unexpectedly distorted reflections, leaving the centre surface completely even and with a true reflection. The legs, slightly inclined, and the supporting structure are in nickel finished steel (for the extra clear mirror top) or bronze (for the bronze mirror), obtained through a galvanic treatment. They are available in two sizes, with different heights.

### dimensioni disponibili / available dimensions

- Ø92 - H45
- L175 - P86 - H40

### finiture disponibili / available finishes

- Specchio extrachiaro / Extralight silvered glass
- Specchio bronzo / Bronze silvered glass

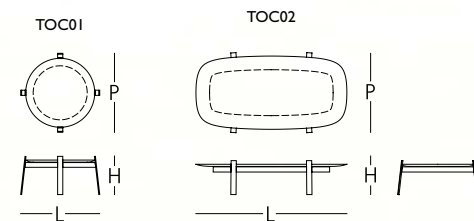

TOC01 Ø 92 - H 45 TOC02 L 175 - P 86 - H 40





**Consolle realizzata in cristallo trasparente di colore rosa e arancio. La base composta da due X in cristallo temperato e stratificato 8+8 mm, con speciali bisellature ed incollaggi, è impreziosita da elementi in metallo cromato lucido. Il piano, in cristallo stratificato 8+8 mm, va in appoggio sulla base.**

Console realized in transparent pink and orange coloured glass. The base composed of two Xs in tempered and laminated 8+8 mm thick glass, with special chamfering and gluing, is embellished by metal polished chrome elements. The top, in laminated 8+8 mm thick glass, leans on the base.

**dimensioni disponibili / available dimensions**

• L175 - P40 - H89

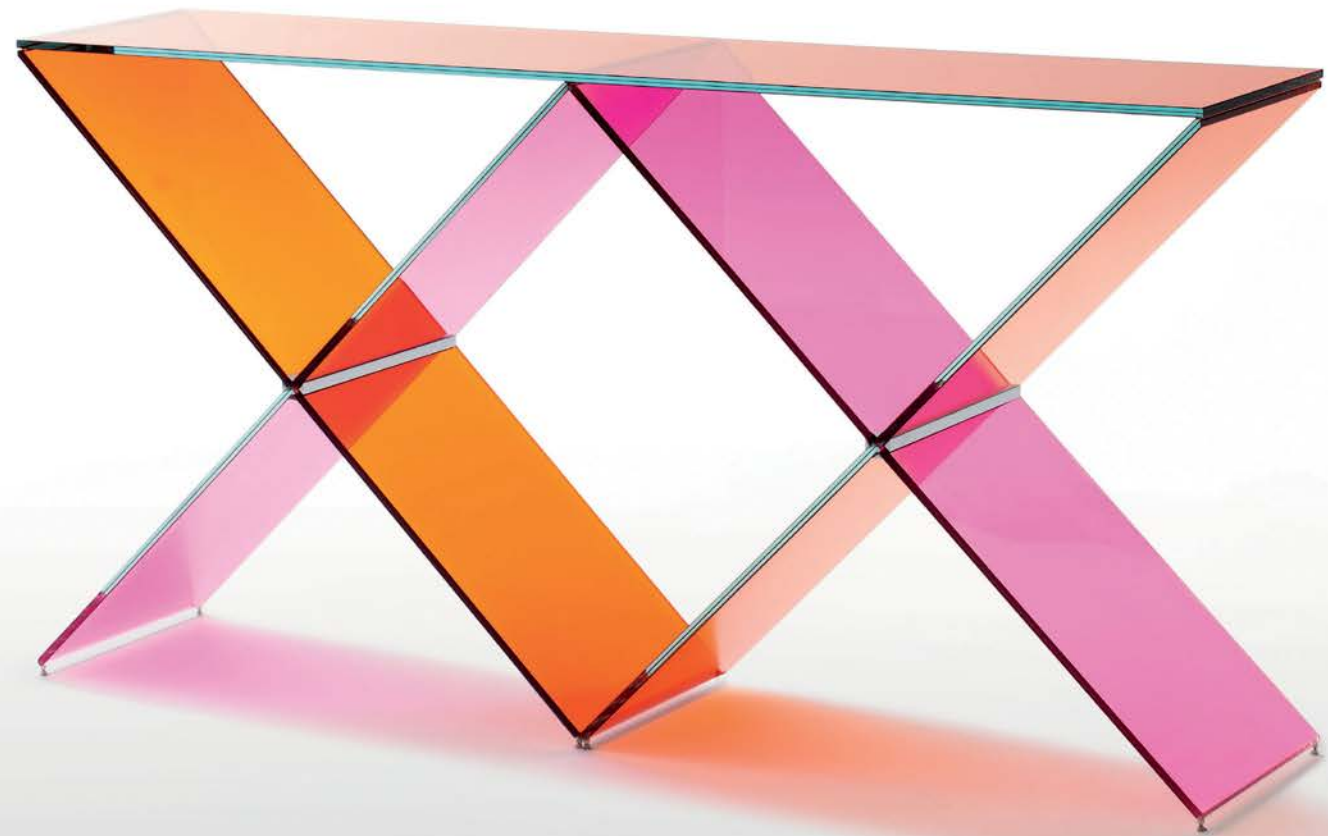

XX03

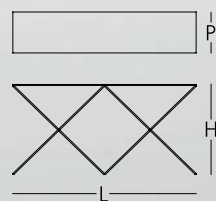

XX03 L175 - P40 - H89



## CONTENITORI

## COMMODORE

Piero Lissoni

**Mobili in cristallo stampato a quadretti 8 mm, temperato e incollato a 45°, con base argentata. Le antine scorrevoli sono inserite in guide di plexiglass trasparente, mentre le esili gambe sono in metallo cromato lucido. Forniti con ripiani in cristallo extrachiaro 8 mm temperato.**

Storage furniture in checked patterned glass 8 mm, tempered and glued 45°, with silvered base. The sliding doors run in transparent plexiglass tracks, whilst the slender legs are in glossy chromium-plated metal. Supplied with 8 mm thick tempered extralight glass shelves.

**dimensioni disponibili / available dimensions**

- L100 - P50 - H120
- L180 - P50 - H96

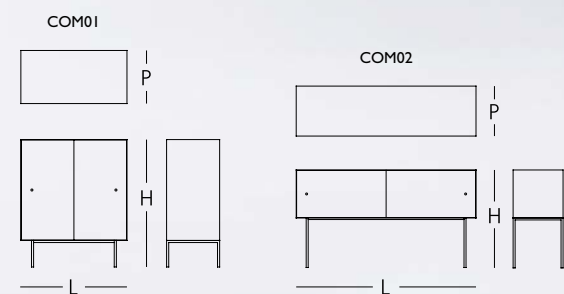

COM01 L100 - P50 - H120 COM02 L180 - P50 - H96



## OLTRALPE

Inga Sempé

81

**Mobili in uno speciale cristallo specchiato dalle forme curve e morbide.**

**La struttura è in cristallo stratificato 6+6 mm completamente specchiante, sia all'interno sia all'esterno.**

**Le ante sono in cristallo specchiante bifacciale 6 mm curvato e temperato, dai riflessi distorti e indefiniti, che rendono il materiale inafferrabile e dall'apparenza quasi liquida.**

**Le ante hanno chiusura blumotion ammortizzata e sono apribili per mezzo di maniglie cilindriche in cristallo.**

Storage units in a special mirrored glass with soft curved shapes.

The structure is in 6+6 mm laminated glass fully mirrored, both inside and outside.

The doors are in 6 mm curved and tempered double-sided mirrored glass, characterized by distorted and undefined reflections, which allow the material to be elusive and optically fluid.

The doors have a blue-motion soft closure and are opened with cylindrical glass handles.

**dimensioni disponibili / available dimensions**

- L96 - P47 - H95
- L44 - P26 - H55

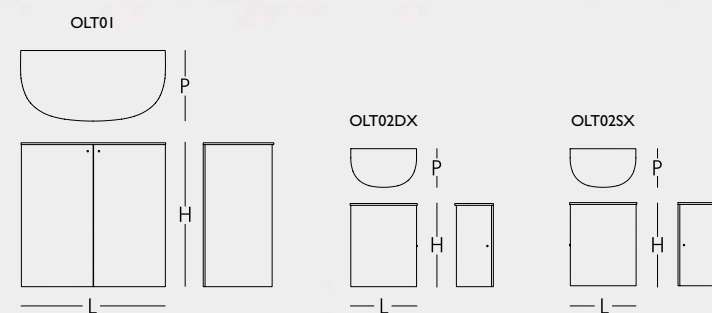

OLT01 L96 - P47 - H95 OLT02DX L44 - P26 - H55 OLT02SX L44 - P26 - H55



## ROBOTIN

Patricia Urquiola

85

**Collezione di tavoli bassi, consolle e mobile contenitore completamente realizzati in uno speciale cristallo specchiante su entrambe le facce, con un pattern decorativo a bolli trasparenti, che simula una lamiera traforata. Tutti i cristalli sono temperati e incollati a UV. Il contenitore è chiuso da due antine con sistema di chiusura push-pull.**

Collection of low tables, consoles and storage furniture, completely created from a special double-sided mirrored glass, with a decorative pattern made from round transparent marks, simulating a perforated metal sheet. All the glass is tempered and UV bonded. The two doors are opened and closed with a push-pull system.

**dimensioni disponibili / available dimensions**

- L132 - P41 - H79
- L164 - P51 - H71
- L56 - P41 - H55
- L112 - P112 - H35
- L120 - P85 - H35

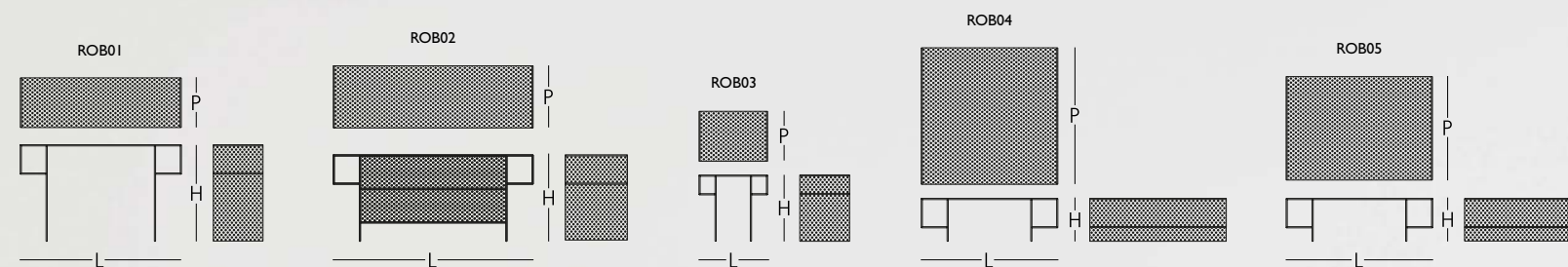

ROB01 L132 - P41 - H79 ROB02 L164 - P51 - H71 ROB03 L56 - P41 - H55 ROB04 L112 - P112 - H35 ROB05 L120 - P85 - H35





**SPECCHI**

## BRIC

Nanda Vigo

**Serie di specchi con bordi perimetralmente bisellati con una profondità di 3 cm. Le forme rettangolari e ovali sono fornite di doppi attacchi orizzontali e verticali.**

Set of mirrors whose external edges are chamfered with a depth of 3 cm. The oval and rectangular-shaped mirrors have a double horizontal and vertical fixture.

**dimensioni disponibili / available dimensions**

- L90 - H180 (ovale)
- L70 - H140 (ovale)

SB01/SB02

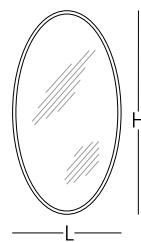

SB01 ovale L90 - H180 SB02 ovale L70 - H140



## CELESTE

Piero Lissoni

**Specchio 5 mm in cristallo extralight, disponibile in forma rotonda e ovale. Lo specchio assume un aspetto magnetico e crea effetti surreali, grazie a tre oblò ingranditori su una superficie completamente piana, ognuno con diametro e grado di ingrandimento differenti. Un delicato bisello perimetrale, rifinisce ed impreziosisce l'oggetto.**

**dimensioni disponibili / available dimensions**

- Ø110 - P3
- L83 - P3 - H160

5 mm extralight mirror available in round or oval shapes. The mirror assumes a magnetic aspect creating surreal effects thanks to three magnifying portholes fixed on a flat surface with each porthole having a different diameter and different degree of magnification. The mirror has a delicate bevelled edge on its perimeter to refine and enhance the beauty of this object.

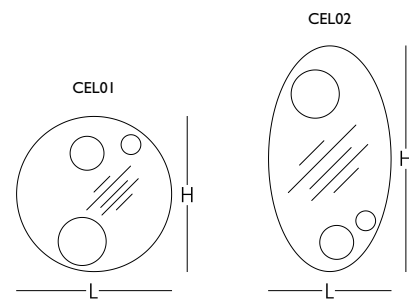

CELO1 Ø110 - P3 CEL02 L83 - P3 - H160



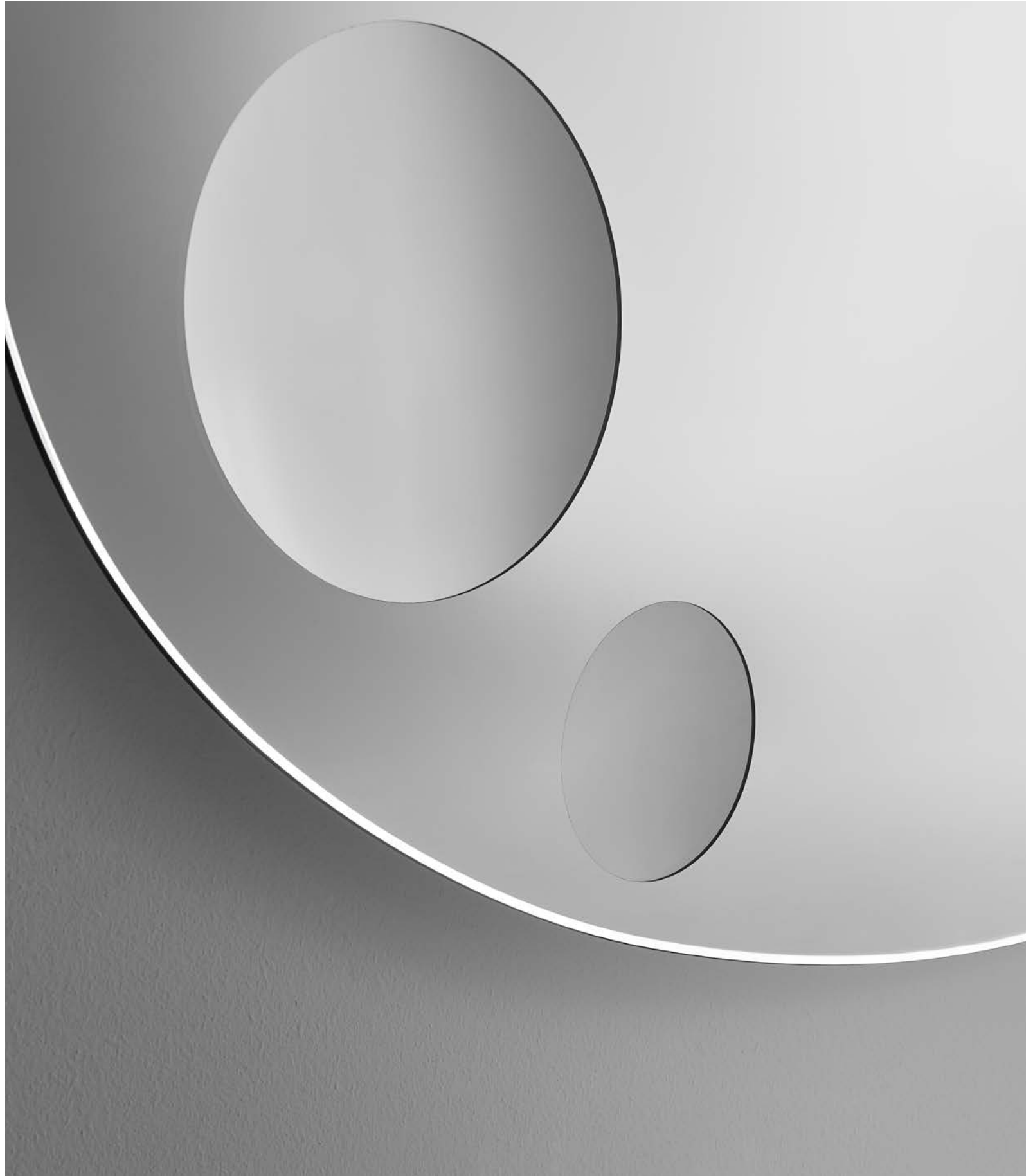

## CONTRO PESO mirror

Ronan Bouroullec

**Specchiera da terra bifacciale basculante, con una struttura in acciaio verniciato opaco RAL 6006 e base realizzata in un blocco di cristallo colato, specchiato tramite argentatura manuale, che funge da zavorra.**

Double-sided tilting and regulated floor mirror; with a structure in RAL 6006 matt lacquered steel and base made from a block of crystal cast, mirrored by manual silvering, which acts as a counterweight.

dimensioni disponibili / available dimensions

• L47 - P25 - H171

CON01

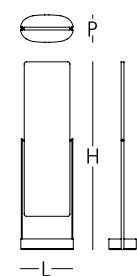

CON01 L 47 - P 25 - H 171

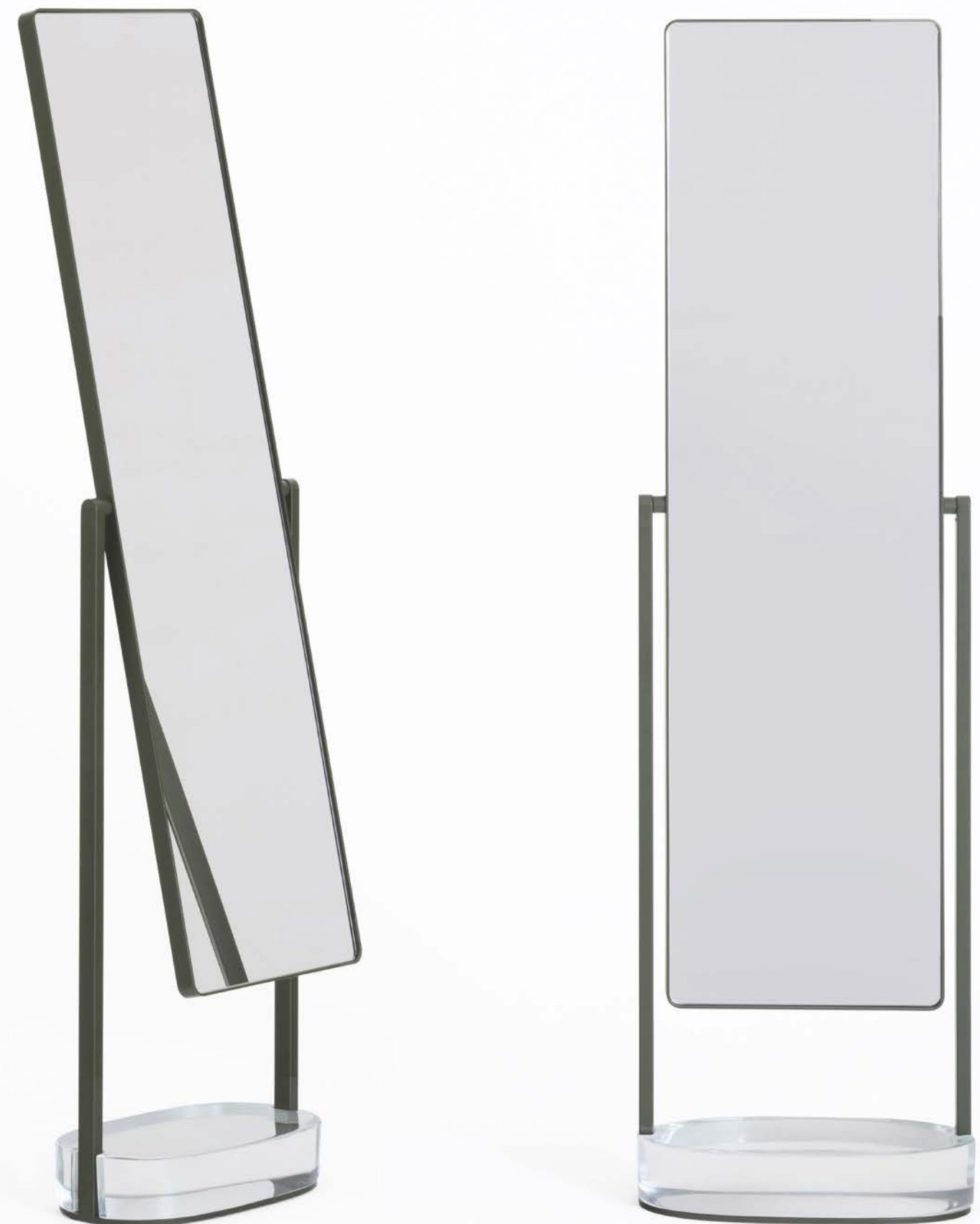



## FICTION

Jean-Marie Massaud

**Serie di specchi disponibili in due misure differenti, realizzati in cristallo extralight con argentatura sfumata digradante, appesi a parete con una barra retro incollata e un cilindro in metallo cromato. Lo specchio piccolo può avere sfumatura digradante verso l'alto o verso il basso.**

Series of mirrors available in two different sizes, realized in extralight glass with degrading shaded silvering, hanging on the wall with a back glued and with a chromium-plated metal cylinder. The small mirror can have a degrading shade upwards or downwards.

**dimensioni disponibili / available dimensions**

- L60 - P7 - H105 (con foro/with hole)
- L60 - P7 - H180 (con foro/with hole)

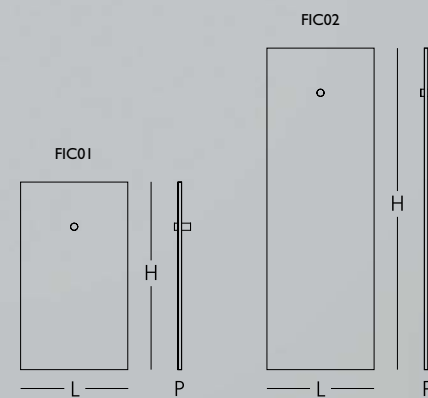

FIC01 L60 - P7 - H105 FIC02 L60 - P7 - H180

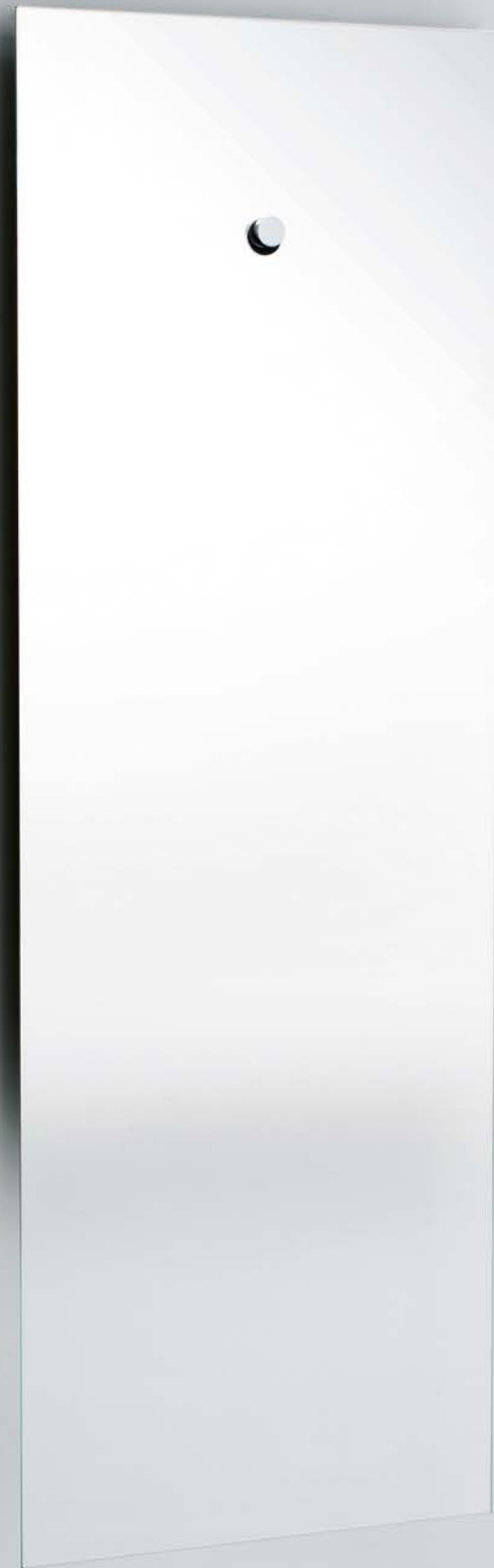

## GLI SPECCHI DI DIONISO

Ettore Sottsass

Collezione di 6 specchi a parete di varie forme e misure caratterizzati da cornici policrome composte da elementi in specchio laminato colorato, in cristallo laminato colorato e in cristallo laccato.

Collection of 6 wall mirrors in different shapes and sizes characterizes by polychromatic frames composed of elements in laminated coloured mirror, coloured laminated glass and lacquered glass.

dimensioni disponibili / available dimensions

- L70 - H64
- L52,5 - H50
- L72 - H52
- L69 - H69
- L63 - H72

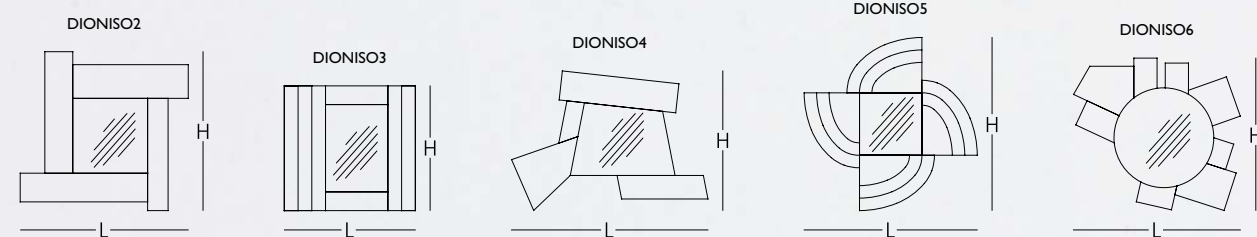

DIONISO2 L70 - H64 DIONISO3 L52,5 - H50 DIONISO4 L72 - H52 DIONISO5 L69 - H69 DIONISO6 L63 - H72





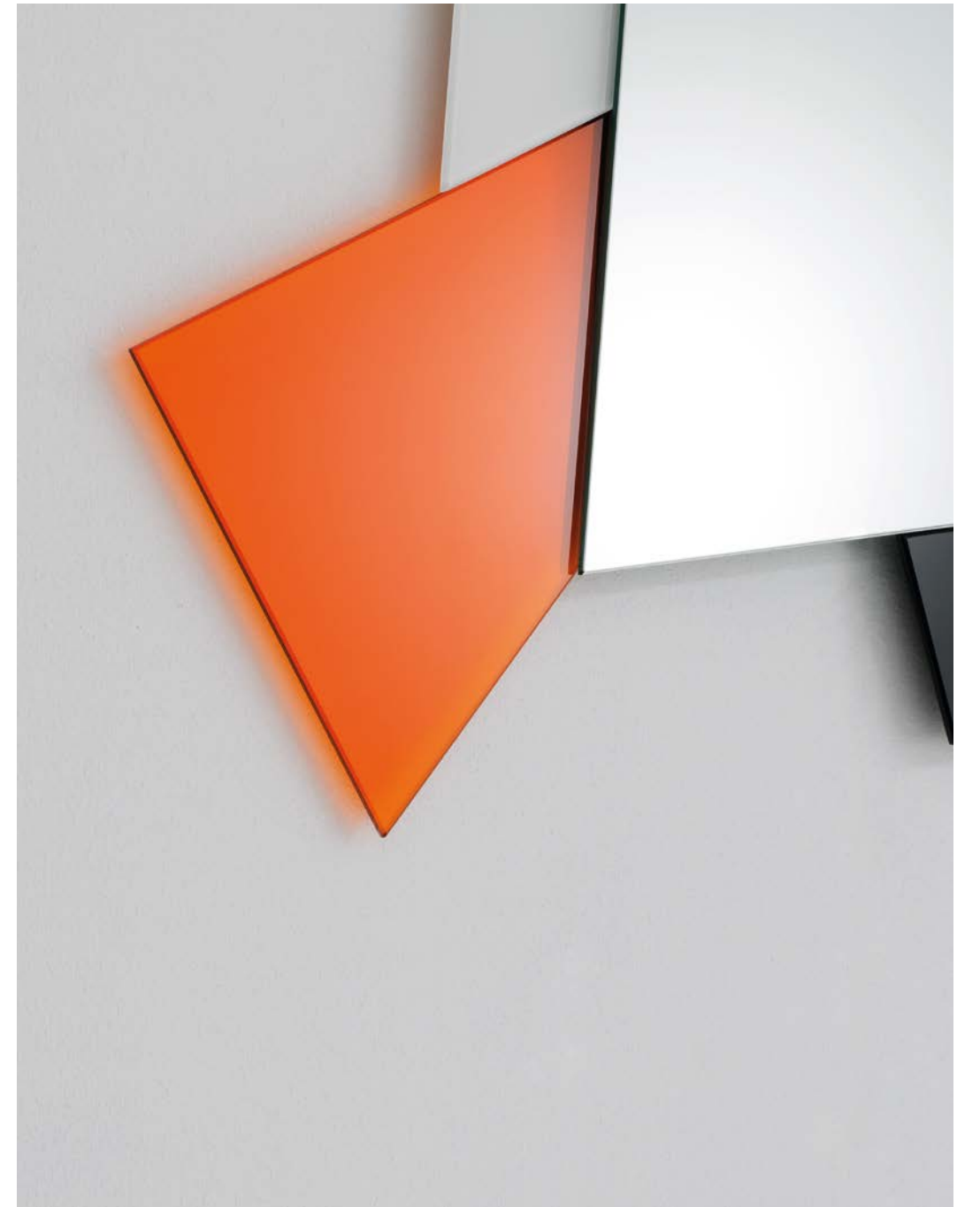



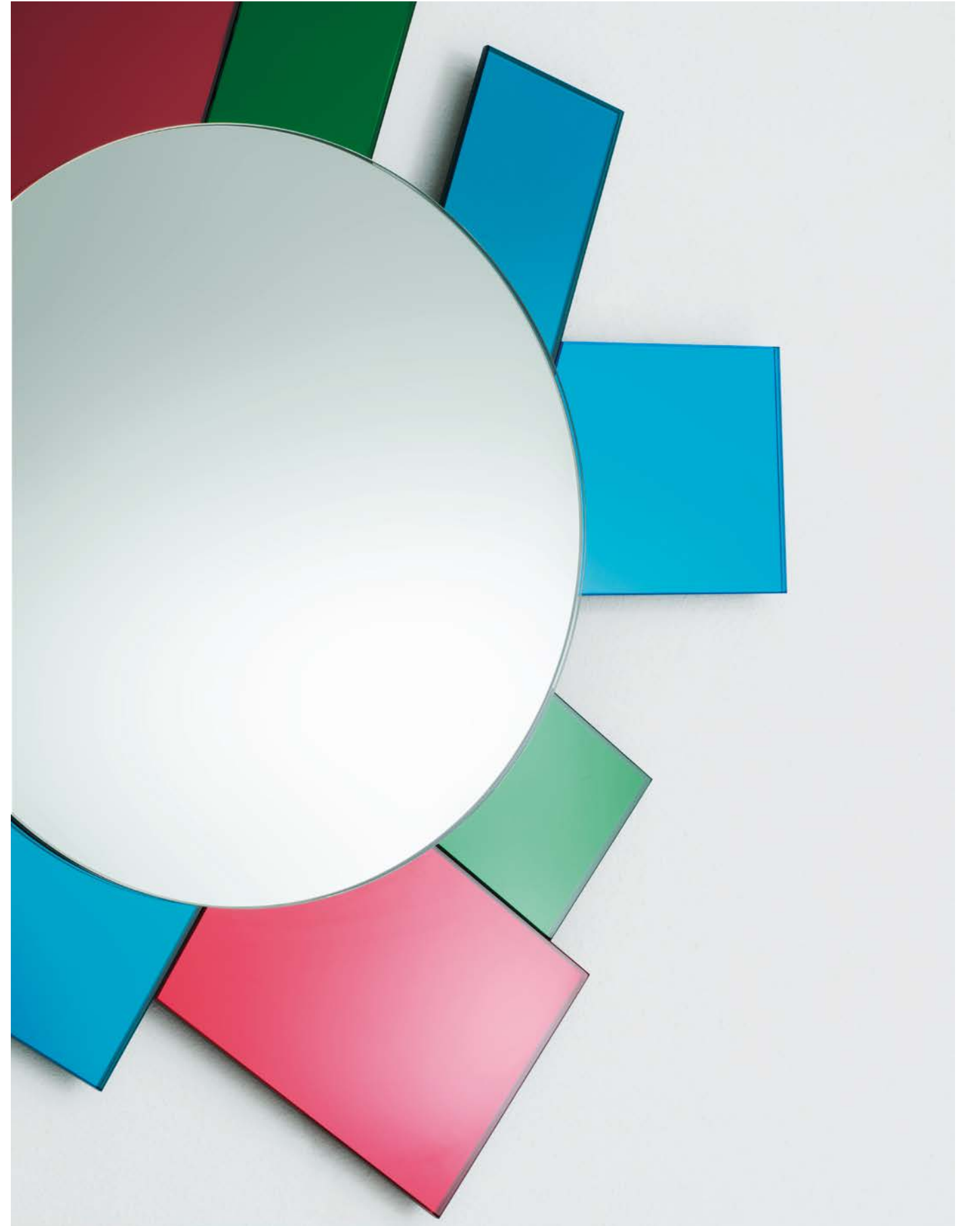
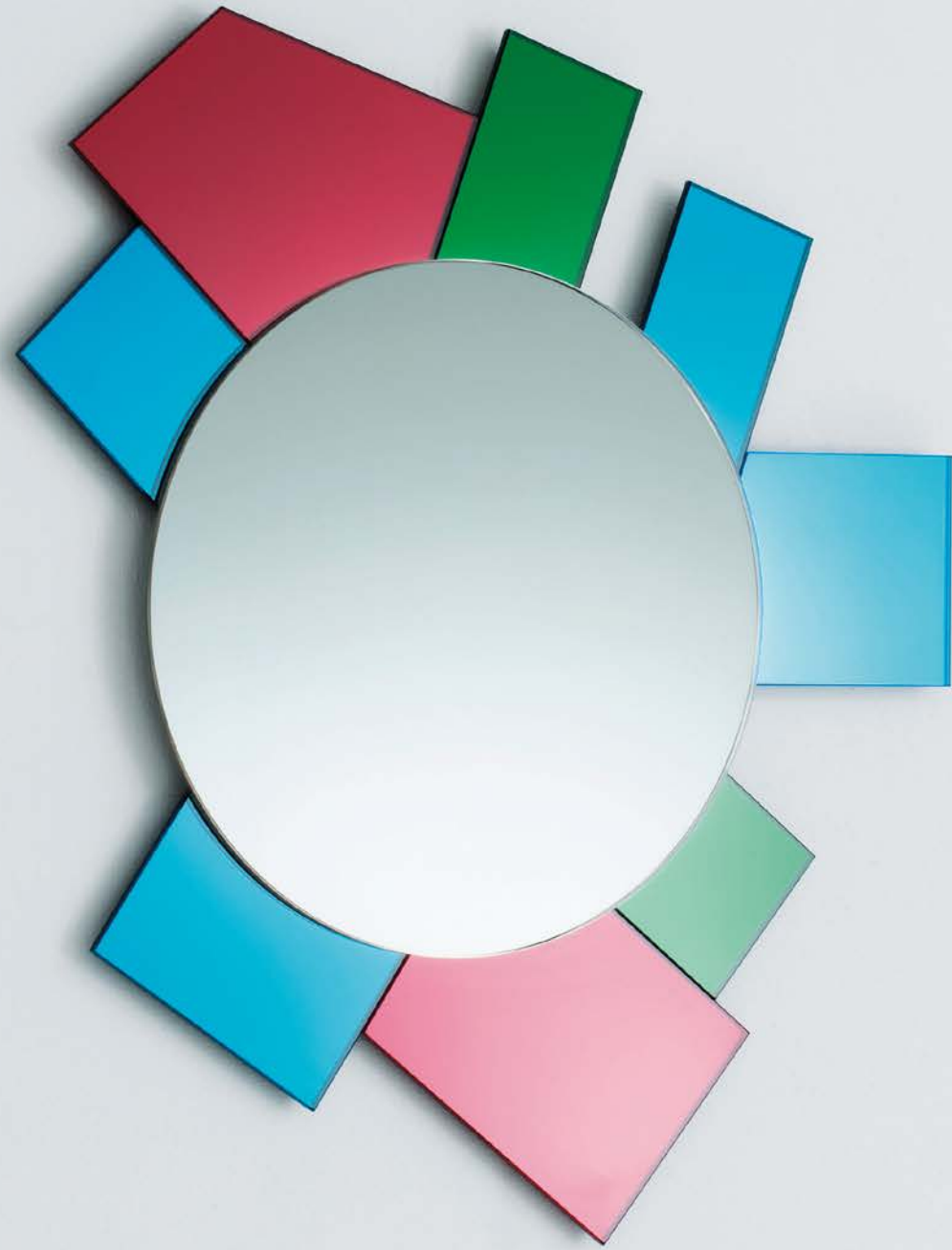

## I MIRROR

Tokujin Yoshioka

**Specchiera da terra autoportante realizzata in cristallo extrachiaro 12 mm curvato e argentato a mano. I bordi verticali sono impreziositi da una raffinata molatura a filo toro. Sul retro, rifinito con una verniciatura color argento, è presente un discreto rinforzo che irrigidisce la lastra di cristallo. Disponibile in tre diverse larghezze, con una zavorra smontabile che conferisce stabilità. La versione più stretta (codice IM101) è provvista anche di una base girevole.**

Free standing floor mirror made from 12 mm extra clear curved and manually silvered glass. The vertical edges are embellish by a unique bullnose edge polishing. On the back, finished with a silver-grey lacquering, there is a discrete reinforcement which stiffens the glass panel. It is available in three different widths, with a removable counterweight which gives stability. The narrower version (code IM101) has a swivel base.

**dimensioni disponibili / available dimensions**

- L50 - P45 - H174
- L85 - P45 - H173
- L120 - P45 - H173

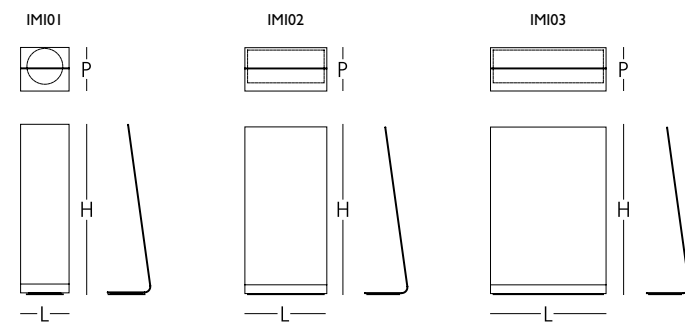

IM101 L50 - P45 - H174 IM102 L85 - P45 - H173 IM103 L120 - P45 - H173





## KOOH-I-NOOR SPECCHI

Piero Lissoni

**Specchio da terra di forma irregolare con perimetro sfaccettato, con speciali bisellature dalle profondità e inclinazioni variabili.**

Standing mirror irregularly shaped with faceted perimeter and special chamferings with variable depths and inclinations.

**dimensioni disponibili / available dimensions**

- L116 - H206
- L150 - H265



KOS01/02

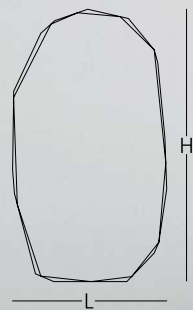

KOS01 L116 - H206 KOS02 L150 - H265



## MAESTRALE

Piero Lissoni

**Specchi realizzati in un'unica lastra di cristallo extrachiaro o blu ondulato alle due estremità e argentato manualmente, in modo da simulare lo sventolio di un drappo o la superficie di un liquido mossa da leggere onde.**

**Le zone ondulate riflettono le immagini distorcendole in maniera inaspettata, mentre la zona al centro, perfettamente piana, garantisce un riflesso fedele e un utilizzo funzionale.**

**Gli specchi, disponibili in due misure, possono essere appesi liberamente in qualsiasi direzione. MAE01 fornito con un set di piedini, può essere posizionato anche a terra.**

Mirrors created from a single sheet of extralight or blue glass undulating at both ends and hand-silvered, simulating the fluttering of a drape or the surface of a liquid moved by slightly waves.

The undulating reflected images are distorted in an unexpected way, whilst the perfectly flat area in the center guarantees a faithful reflection and a functional use.

The mirrors, available in two sizes, can be freely hung in any direction.

MAE01 supplied with a set of feet, can also be placed on the ground.

dimensioni disponibili / available dimensions

- LI15 - P11 - H196
- LI15 - P11 - H90

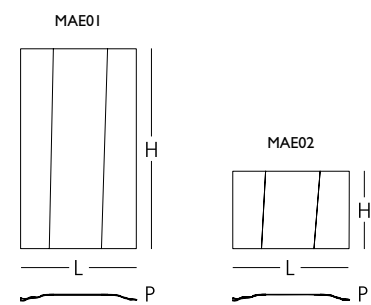

MAE01 LI15 - P11 - H196 MAE02 LI15 - P11 - H90





## MARLENE

Philippe Starck with Sergio Schito

**Serie di specchi a parete di grande eleganza, ottenuti curvando una lastra di cristallo extrachiaro 6 mm, sagomato e molato filo lucido, e argentandola manualmente. La parte centrale e le due ali laterali riflettono l'immagine in maniera fedele e funzionale, mentre le superfici curve deformano l'immagine in maniera inaspettata. Il retro dello specchio è disponibile nei colori rosa, bianco o argento. I codici MAR03 e MAR04 possono essere appoggiati a terra tramite piedini cromati in dotazione.**

A collection of elegant wall mirrors, created by bending a slab of extralight 6 mm glass, moulded and shiny ground polished and then manually silvered. The central part and the two lateral sides give true reflection, whilst the curved part of the surface distorts the reflection randomly and unexpectedly. The back of the mirror is available in pink, white or silver colour. The codes MAR03 and MAR04 can be placed on the floor by means of the supplied chromed feet.

### dimensioni disponibili / available dimensions

- L75 - P12 - H77
- L100 - P17 - H56
- L95 - P20 - H185

### finiture disponibili / available finishes

- Retro colore argento /  
Back in silver colour
- Retro colore bianco /  
Back in white colour

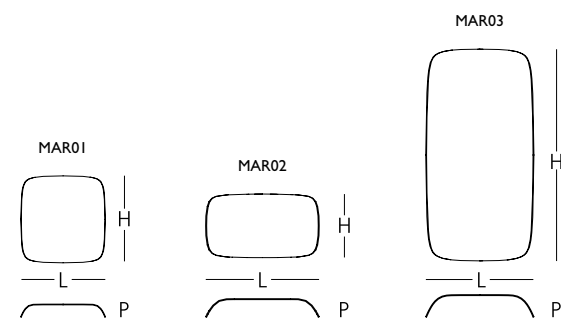

MAR01 L75 - P12 - H77 MAR02 L100 - P17 - H56 MAR03 L95 - P20 - H185







## MENTEUR

Philippe Starck

**Specchi realizzati in un'unica lastra di cristallo extrachiaro, che, grazie ad innovative e complesse tecniche di lavorazione, è curvata su tutto il perimetro e argentata manualmente a regola d'arte. A seconda della faccia argentata, si ottiene uno specchio dalla superficie concava o convessa, con una cornice che riflette le immagini distorcendole in maniera inaspettata, mentre la zona al centro, perfettamente piana, garantisce un riflesso fedele e un utilizzo funzionale. Disponibili in due formati, la forma rettangolare può essere appesa in entrambe le direzioni. La forma concava è disponibile retroverniata nei colori argento o arancio Pantone 163C.**

Mirrors made from a single sheet of extra-clear glass, which, thanks to innovative and complex bending techniques, is curved around its entire perimeter and manually silvered to perfection. Depending on the silver face, a mirror with a concave or convex surface is obtained, with a frame reflecting the images and distorting them at random, while the area in the center, perfectly flat, guarantees a true reflection and functional use. Available in two sizes, the rectangular shape can be hung in either direction. The back side of the concave version is available in the colours silver or orange Pantone 163C.

**dimensioni disponibili / available dimensions**

- L85 - P5 - H175
- L85 - P5 - H175
- Ø80 - P5
- Ø80 - P5

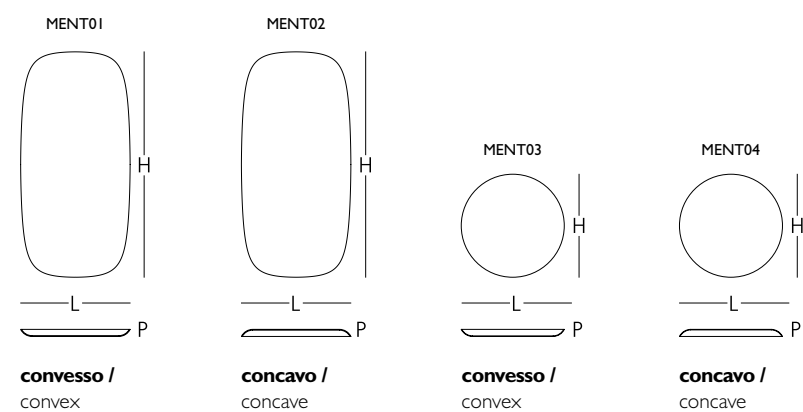

MENT01 L85 - P5 - H175    MENT02 L85 - P5 - H175    MENT03 Ø80 - P5    MENT04 Ø80 - P5







## SCRIBBLE

YabuPushelberg

**Specchio in cristallo extralight 5 mm, caratterizzato da un gesto artistico e ironico. La superficie specchiante, infatti, è come se fosse disegnata a mano libera con un pennello su un fondo neutro di colore nero, oppure rivestito con una preziosa foglia d'argento anticata. Lo specchio può essere appeso in tutte e quattro le posizioni.**

Mirror produced in 5 mm thick extralight glass, characterized by an artistic and ironic sign. The mirrored surface, in fact, is as if it were drawn freehand with a brush on a neutral black background or coated with a precious antiqued silver leaf.

The mirror can be hung in all four positions.

**dimensioni disponibili / available dimensions**

- L60 - H60
- L75 - H100
- L80 - H180



SCR101



SCR102



SCR103

SCR101 L60 - H60 SCR102 L75 - H100 SCR103 L80 - H180



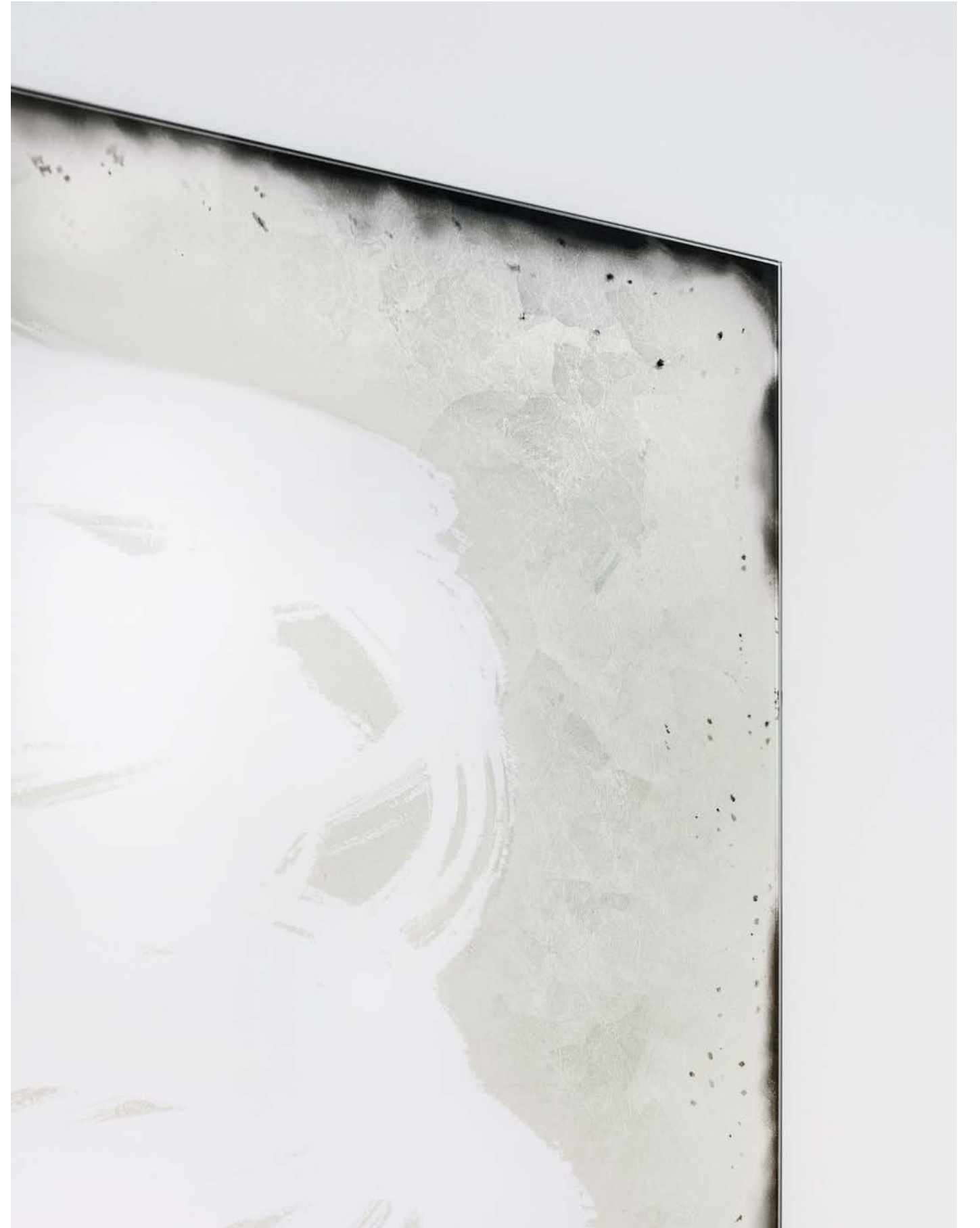



## SHIMMER SPECCHI

Patricia Urquiola

**Serie di specchi realizzati in cristallo extrachiaro, nei quali, con sofisticate tecniche di lavorazione, si integrano e si fondono una specchiatura sfumata digradante e la meravigliosa finitura multicolorata cangiante, caratteristica della collezione Shimmer. Ne risulta uno specchio magico ed ammaliante, dall'aspetto animato, continuamente mutevole al variare dell'incidenza della luce e del punto di osservazione. Ad eccezione del modello SHS03, è disponibile anche una versione con impianto luminoso.**

A series of mirrors in extralight glass. Made with refined processing techniques, a degrading shaded silvering mix and the magnificent iridescent multichromatic finish, a feature of the Shimmer collection. A magical, fascinating and animated mirror; continuously variable according to the angle of the light source and the vantage point. Except for the model SHS03, a version with light is also available.

dimensioni disponibili / available dimensions

- L100 - P5 - H80
- L125 - P5 - H100
- L100 - P5 - H180
- Ø60 - P5
- Ø80 - P5

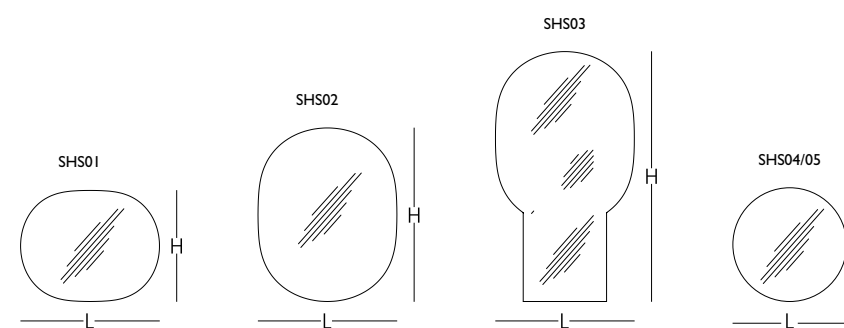

SHS01 L100 - P5 - H80 SHS02 L125 - P5 - H100 SHS03 L100 - P5 - H180 SHS04 Ø60 - P5 SHS05 Ø80 - P5



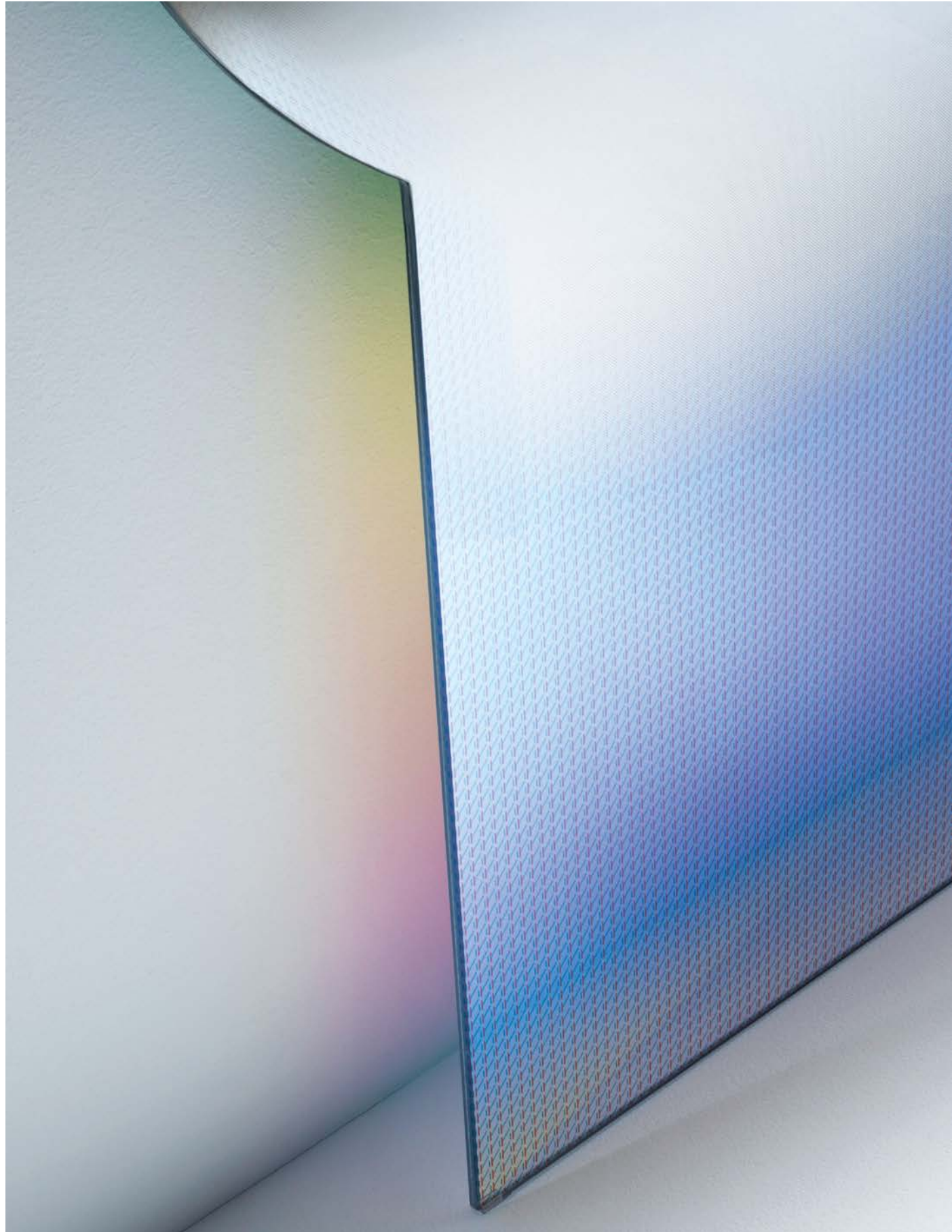

## STURM UND DRANG

Piero Lissoni

147

**Specchio di grande magnificenza con cornice in cristallo di Murano, ottenuta grazie a complesse e raffinate lavorazioni manuali, che rendono ogni pezzo unico ed irripetibile. La cornice è composta da diversi elementi, che vengono fissati ad un pannello appeso a parete, sul quale viene poi applicato uno specchio bisellato da 5 mm.**  
**Disponibile anche con un impianto di illuminazione a Led, che enfatizza e valorizza la cornice.**

A truly magnificent mirror with Murano glass frame, achieved through a complex and refined hand-made production process, making each piece unique and unrepeatable. The frame is composed of various elements which are fixed to a wall hanging structure upon which a 5 mm thick chamfered mirror is then applied.  
Available also with a Led lighting system, which enhances and exalts the frame.

### dimensioni disponibili / available dimensions

- L210 - P20 - H230
- L150 - P20 - H150 (con luce/with light)

### finiture disponibili / available finishes

Con luce / With light

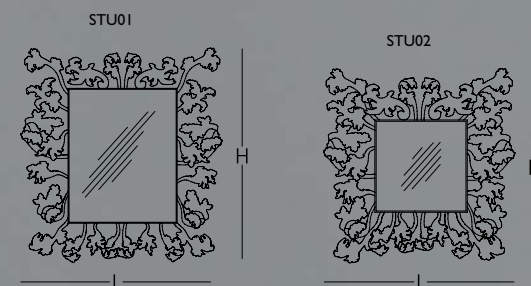

STU01 L210 - P20 - H230 STU02 L150 - P20 - H150 (con luce/with light)



**COMPLEMENTI**

## ANGELO E ANGELA

Jean-Marie Massaud

**Vasi composti da un involucro a forma di parallelepipedo, realizzato in cristallo fumè, incollato a 45°, e da una scultura in ceramica di forma organica, sostenuta e contenuta al suo interno. L'elemento in ceramica, disponibile nelle finiture bianco opaco o laccato platino, è cavo e può contenere acqua. Disponibile in due differenti forme e misure.**

A series of vases composed of a parallelepiped shaped case, realized in smoked glass, glued 45°, and an organic shaped ceramic sculpture, supported and contained in its inside.

The ceramic element, available in the finishes opaque white or platinum lacquered, is hollow and can contain water.  
Available in two different shapes and sizes.

**dimensioni disponibili / available dimensions**

- L20 - P20 - H60
- L60 - P23 - H45

**finiture disponibili / available finishes**

Bianco opaco e laccato platino /  
Opaque white and platinum lacquered

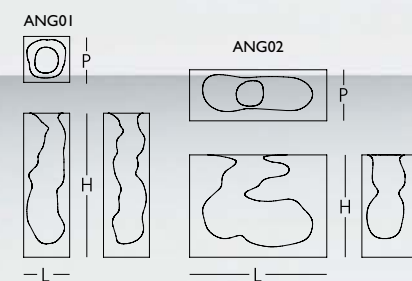

ANG01 L20 - P20 - H60 ANG02 L60 - P23 - H45



## TELEGRAFO

Piero Lissoni

**Porta abiti a piantana di grande leggerezza e rigore formale. Lo stelo, realizzato incollando barre quadrate di cristallo trasparente da 24x24 mm, è fissato mediante un sistema ad incastro ad una base in metallo verniciato nero opaco di grosso spessore. Nonostante l'estrema esilità delle sezioni, il cristallo, grazie ad uno speciale trattamento di tempera, assume un'incredibile resistenza ai carichi.**

Coat stand with great lightness and formal accuracy. The stem is achieved by gluing square bars of 24x24 mm thick transparent glass fixed by means of a joint system to a base made of very thick black opaque varnished metal. Despite the extreme thinness of the sections, the crystal glass has a high load resistance thanks to a special tempering treatment.

dimensioni disponibili / available dimensions

• Ø30 - H 164

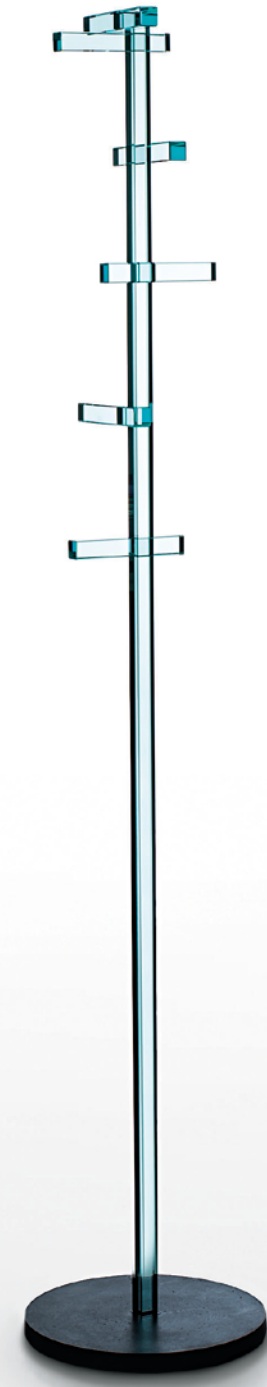

TELO1

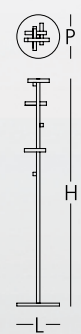

TELO1 Ø30 - H 164



# TRANSFORMER

Piero Lissoni

**Collezione di vasi in cristallo borosilicato con forme cilindriche e coniche deformate in maniera casuale e irregolare attraverso un processo termico, in modo che ogni pezzo risulti essere diverso dall'altro e non riproducibile. Queste lavorazioni manuali rendono quindi ogni vaso unico e speciale.**

Collection of vases in borosilicate glass with cylindrical and conical shapes, manually twisted in a casual and irregular manner through a thermal process so that each piece is a one-off and cannot be reproduced. This hand-made production makes each vase unique and special.

**dimensioni disponibili / available dimensions**

- Ø18 H30
- Ø23 H39
- Ø22 H27
- Ø32 H39
- Ø22 H26
- Ø33 H39
- Ø23 H34
- Ø17 H38

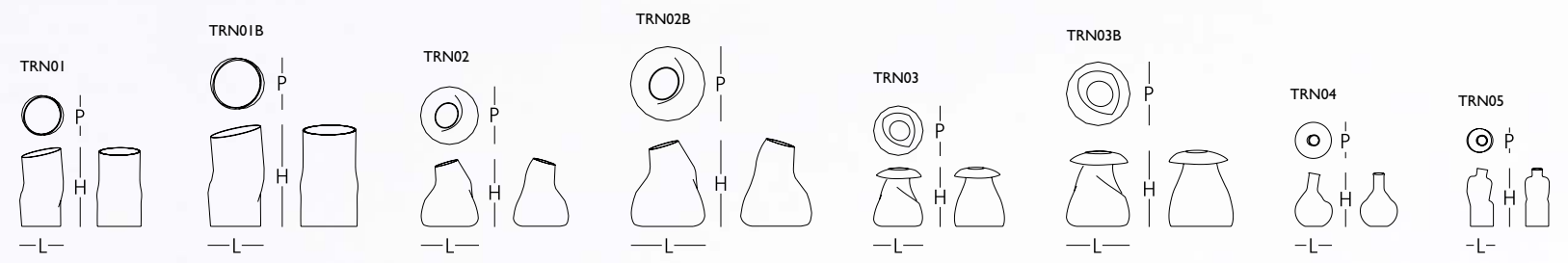

TRN01 Ø18 H30 TRN01B Ø23 H39 TRN02 Ø22 H27 TRN02B Ø32 H39 TRN03 Ø22 H26 TRN03B Ø33 H39 TRN04 Ø23 H34 TRN05 Ø17 H38

## TUTUBE

Marc Krusin

**Vasi cilindrici in cristallo borosilicato trasparente.**  
**Grazie ad una complessa e raffinata lavorazione di soffiatura, all'interno del cilindro viene creata una concavità che presenta soluzione di continuità con l'esterno.**  
**Disponibile in due altezze differenti.**

Cylindrical vases in borosilicate transparent glass.  
Thanks to a complex and refined blowing manufacturing, a concavity, presenting continuity of solution with the outside, is created in the inside of the cylinder. Available in two different heights.

**dimensioni disponibili / available dimensions**

- Ø15 - H37,5
- Ø15 - H50

TUT01/02

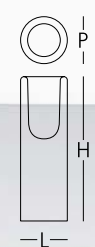

TUT01 Ø15 - H37,5 TUT02 Ø15 - H50



< INDEX

**SEDUTE**

## BENT GLASS BENCH & BENT GLASS STOOL

Naoto Fukasawa

163

**Panca e sgabello con un aspetto di naturale semplicità, realizzati in cristallo trasparente extralight 12 mm, sagomato e curvato. La particolare curvatura del vetro e uno speciale processo di tempera conferiscono al cristallo una straordinaria resistenza ai carichi. È disponibile anche una versione in cristallo argentato dall'aspetto molto prezioso.**

Bench and stool with an aspect of natural simplicity, made from shaped and curved 12 mm thick transparent extralight glass. The particular glass curvature and a special tempering process endow the glass with an extraordinary load resistance. It is also available a version in silver glass with a precious appearance.

**dimensioni disponibili / available dimensions**

- L200 - P49 - H41
- L40 - P49 - H40

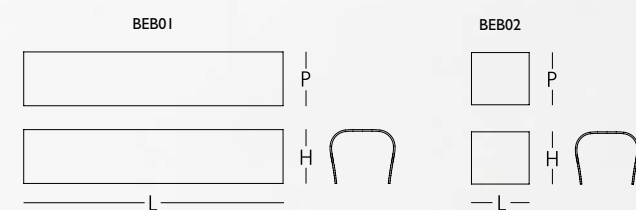

BEB01 L200 - P49 - H41 BEB02 L40 - P49 - H40

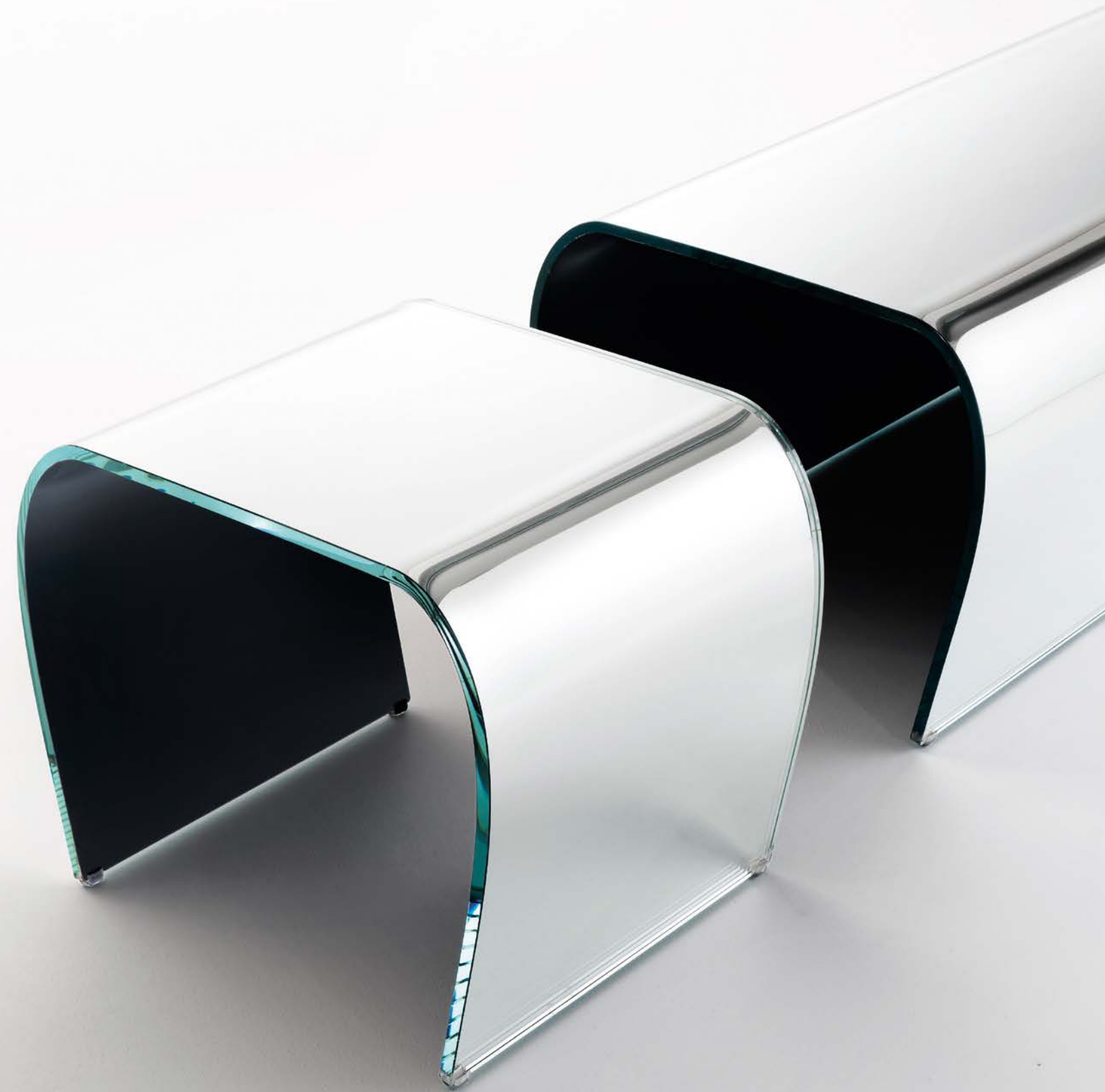

## CRYSTAL STOOL

Philippe Starck

167

**Sgabello-piccolo tavolino in cristallo trasparente 24 mm temperato, incollato a UV. Grazie a sofisticate e complesse lavorazioni è stato realizzato un oggetto completamente in cristallo, estremamente resistente ai carichi e dai dettagli magistralmente risolti. Dei discreti piedini in acciaio inox lucidato a specchio rifiniscono ed impreziosiscono l'oggetto.**

Stool - small table in 24 mm tempered transparent glass - UV bonded. Following sophisticated and complex manufacturing processes, an object entirely in glass has been created with high load resistance and masterfully resolved details. Discreet mirror-polished stainless steel little feet finish and embellish the object.

**dimensioni disponibili / available dimensions**

• Ø 32 - H 48

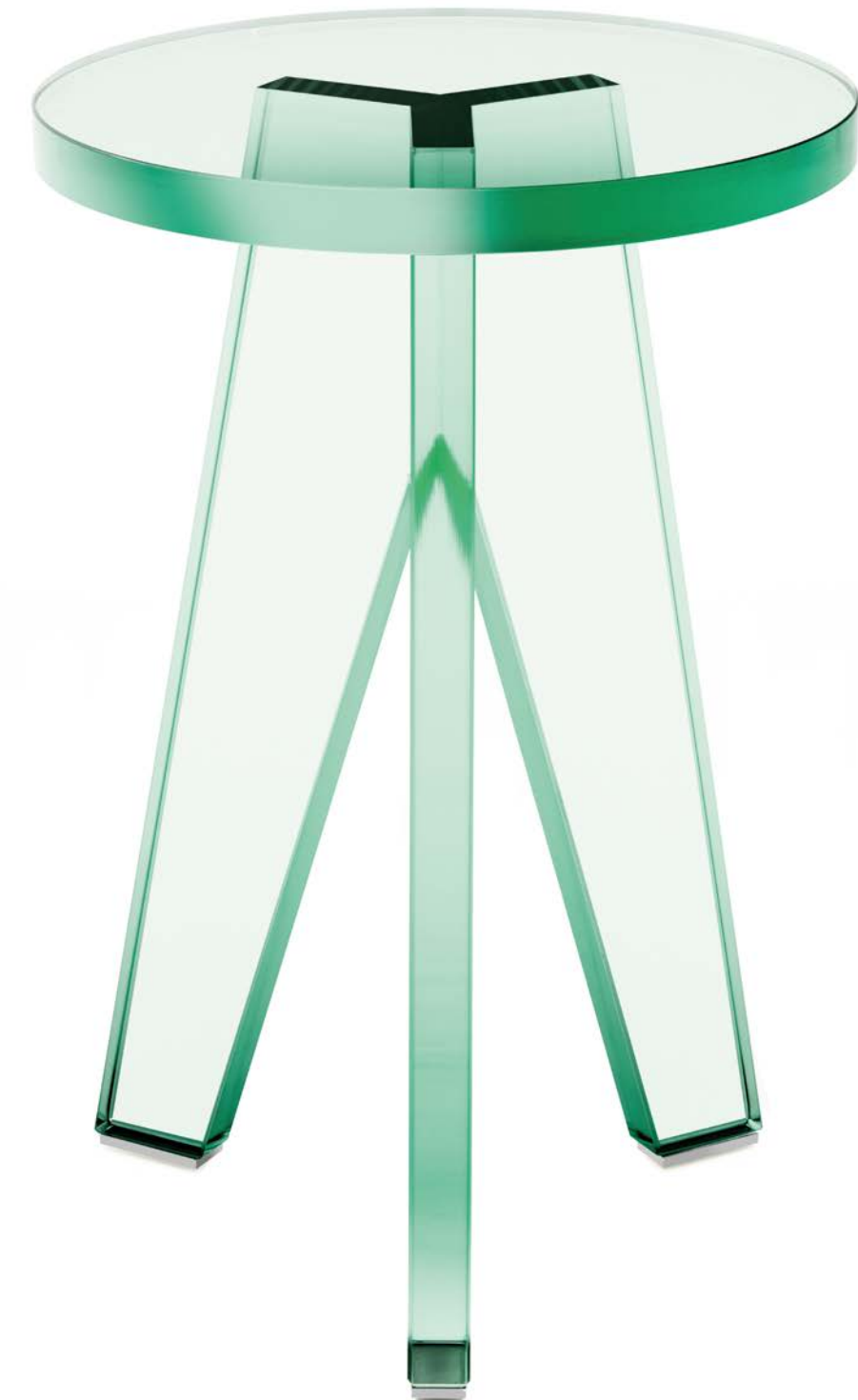

CRY01

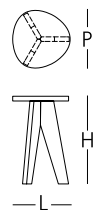

CRY01 Ø 32 - H 48

< INDEX

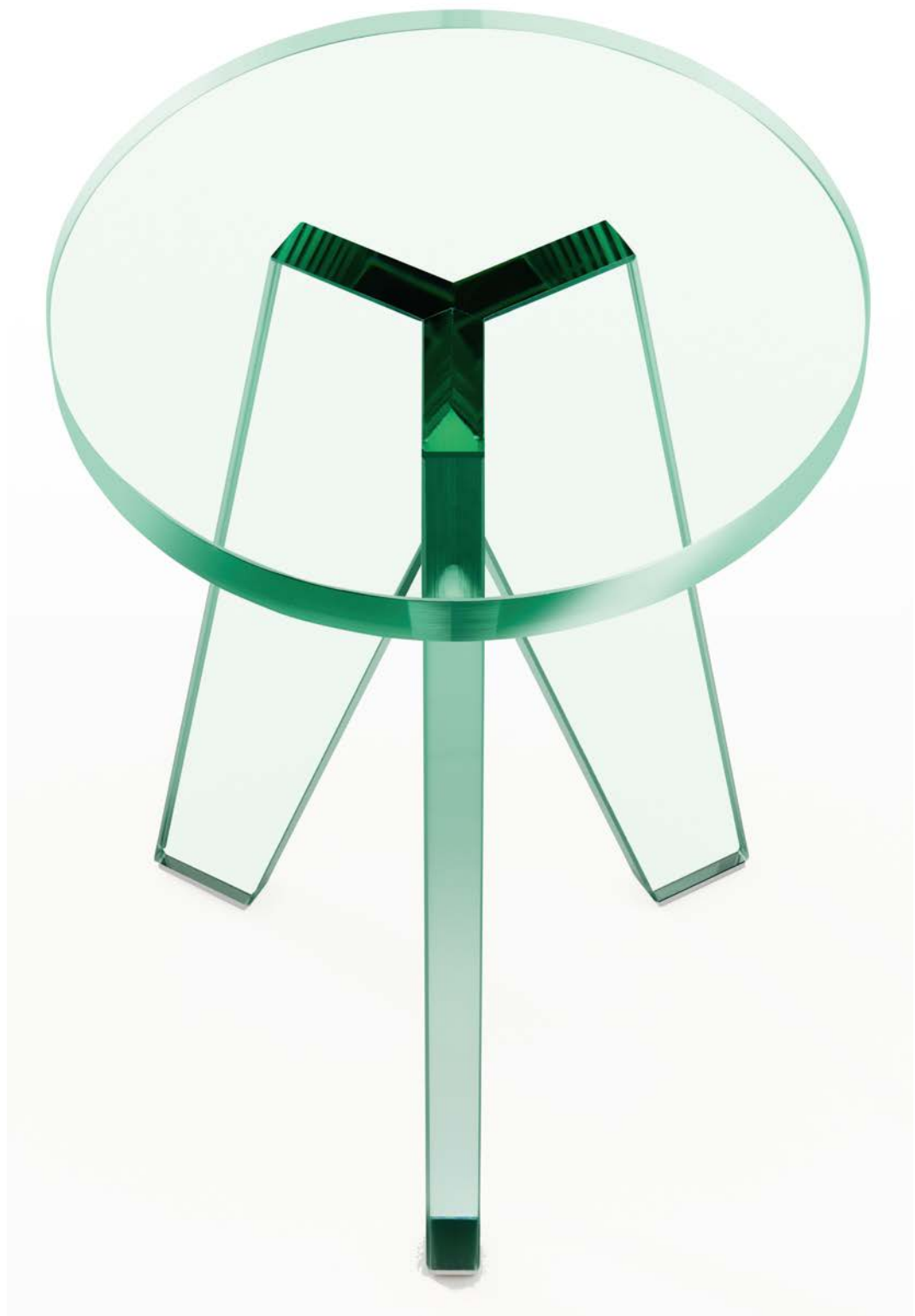

GLAS

Sede, direzione commerciale e showroom:  
Via Cavour, 29 - 20846 Macherio (MB) - I  
tel: +390392323202 ra fax +390392323212  
e-mail: [glas@glasitalia.com](mailto:glas@glasitalia.com) - [www.glasitalia.com](http://www.glasitalia.com)

