

BOXINBOX
DESIGN PHILIPPE STARK

Istruzioni di montaggio ed utilizzo
Assembling and use instruction

GLAS
ITALIA

BIB01/02/03/05

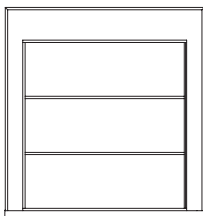

BIB04/06

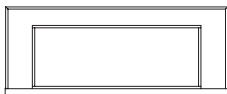

BIB07



BIB08

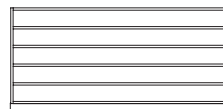

step 1 BIB01/BIB02/BIB03/BIB05

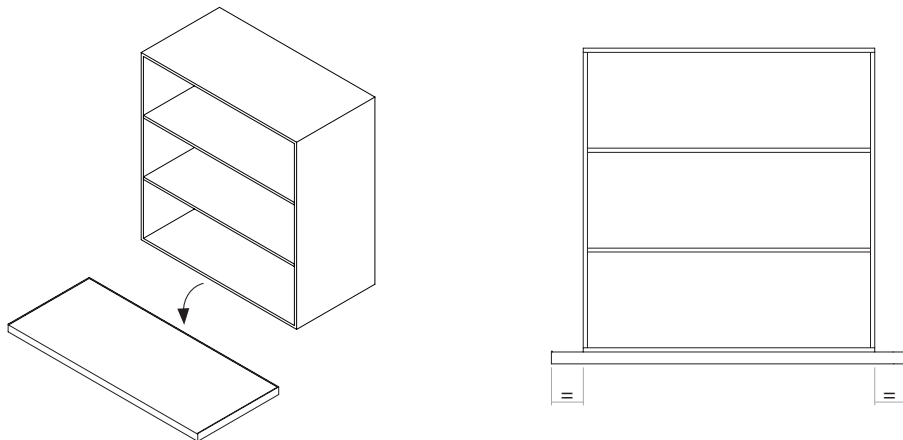

step 2 BIB01/BIB02/BIB03/BIB05

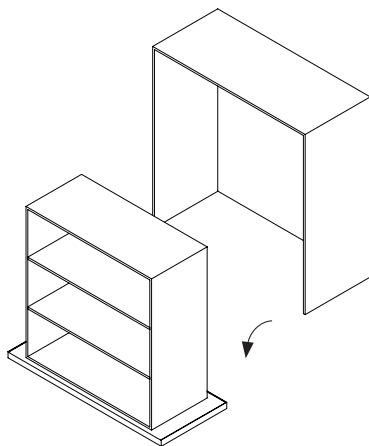

step 3 BIB01/BIB02/BIB03/BIB05

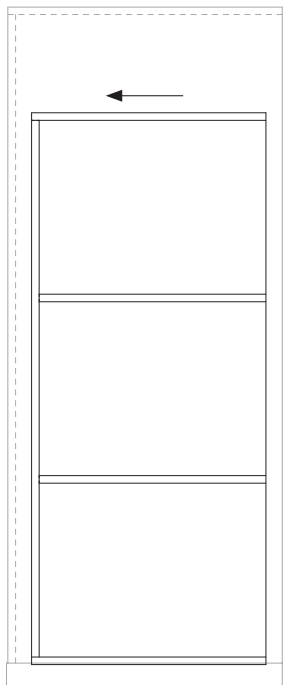

step 3b BIB04/BIB06

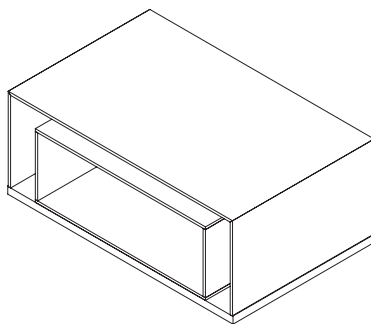

step 1b BIB07/BIB08

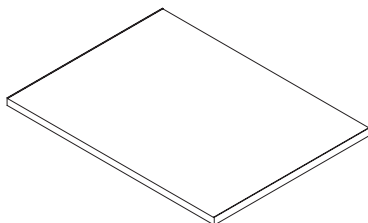
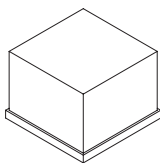

ATTENZIONE

Nel maneggiare i componenti in cristallo evitare urti e non appoggiarli su superfici che possano causare scheggiature o graffi.

ATTENTION

When handling glass components, please avoid shocks and do not lay them on surfaces that could cause chips or scratches.

ATTENTION

En maniant les composants en cristal éviter les heurts et ne pas les appuyer sur des surfaces qui puissent causer des ébréchures ou des griffures.

ACHTUNG

Während der Handhabung der Glasbestandteile vermeiden Sie Stöße und achten Sie darauf, sie nicht auf Oberflächen abzustellen, die diese zersplittern oder verkratzen könnten.

ATENCIÓN

Al desplazar las piezas de cristal, evitar choques y evitar apoyarlas sobre superficies que puedan crear marcas o rayas.

step 2b BIB07/BIB08

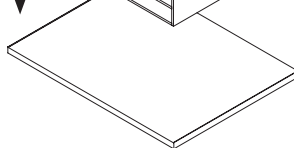
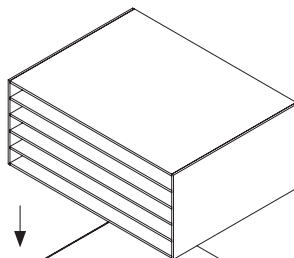
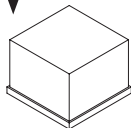
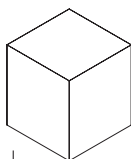

BOXINBOX cod. BIB01/BIB02/BIB03/BIB05/BIB06

ITALIANO

step 1. Posizionare la base a terra e appoggiarvi sopra, centrandolo, il volume di vetro interno.

step 2. Posizionare volume esterno sulla base.

step 3. Per **BIB01/BIB02/BIB03/BIB05**, spingere delicatamente il volume interno contro lo schienale del volume esterno.

step 3b. Per **BIB04/BIB06**, che sono sprovvisti di schienale, il volume interno va posizionato a filo della base.

ENGLISH

step 1. Place the base on the floor and lay on it, centering, the volume of the internal volume.

step 2. Place the external volume on the base.

step 3. For **BIB01/BIB02/BIB03/BIB05**, push carefully the internal volume against the back of the external one.

step 3b. For **BIB04/BIB06**, which have not the back, the internal volume should be placed at the flush of the base.

FRANCAIS

step 1. Placez la base sur le sol et appuyer sur, au centre, le volume de la vitre intérieure.

step 2. Placez le volume externe sur la base.

step 3. Pour **BIB01/BIB02/BIB03/BIB05**, poussez doucement le volume intérieur contre le dos du volume externe.

step 3b. Pour **BIB04/BIB06**, qui sont dépourvues du dossier, le volume interne doit être placé au ras de la base.

DEUTSCH

step 1. Stellen Sie das Untergestell auf den Boden und legen Sie dann das innere Volumen aus Glas auf das Untergestell auf. Zentrieren Sie die innere Glasstruktur.

step 2. Legen Sie das äußere Volumen auf das Untergestell.

step 3. Für **BIB01/BIB02/BIB03/BIB05** stellen Sie leicht die Rückseite des inneren Volumens gegen die einige des äußeren Volumens.

step 3b. Für **BIB04/BIB06**, die ohne Rückseite sind, soll das innere Volumen bündig mit dem Untergestell positioniert werden.

ESPAÑOL

step 1. Posicionar la base al suelo y apoyar, centrandolo, el volumen interior de cristal en la base .

step 2. Posicionar el volumen exterior en la base.

step 3. Para **BIB01/BIB02/BIB03/BIB05**, empujar con delicadez el volumen interior contra la trasera del volumen exterior.

step 3b. Para **BIB04/BIB06**, donde hay la trasera, el volumen interior se posiciona al hilo de la base.

BOXINBOX cod. BIB07/BIB08

ITALIANO

step 1b. Posizionare la base a terra.

step 2b. Appoggiarvi sopra il volume in vetro e allinearlo usando la massima delicatezza.

ENGLISH

step 1b. Place the base on the floor.

step 2b. Gently lay on it the glass volume and align it.

FRANCAIS

step 1b. Positionner la base sur le sol.

step 2b. Appuyer au-dessus le volume en verre et l'aligner en utilisant la plus grande délicatesse.

DEUTSCH

step 1b. Stellen Sie das Untergestell auf den Boden.

step 2b. Legen Sie leicht das Glasvolumen auf das Untergestell und lassen Sie sie ausrichten.

ESPAÑOL

step 1b. Posicionar la base al suelo.

step 2b. Apoyar el volumen de cristal en la base utilizando la máxima delicadez y alinearlos.

