



SHERAZADE

**Sistema scorrevole | Anta scorrevole | Montaggio
Sliding system | Sliding door | Installation**

Installazione anta scorrevole / Sliding door installation

Installazione 1 anta scorrevole / 1 sliding door configuration	pag.	1.102
Esploso componenti / Components exploded diagram	pag.	1.103
Installazione perno a pavimento / Floor pivot installation	pag.	1.107
Installazione anta / Door installation	pag.	1.109
Regolazione anta / Door adjustment	pag.	1.110
Posizionamento tappo con logo / Closure cap with logo positioning	pag.	1.111
Installazione configurazione 4 ante scorrevoli / 4 sliding door configuration installation	pag.	1.112

ATTENZIONE: Per evitare rumori e vibrazioni durante lo scorrimento delle ante, le ruote dei carrelli e l'interno del binario devono essere perfettamente puliti.

AVERTISSEMENT : Pour éviter le bruit et les vibrations pendant le glissement des portes, les roues des chariots et l'intérieur du rail doivent être parfaitement propres.

ACHTUNG: um Geräusche und Vibrationen während des Gleitens der Türen zu vermeiden, sollen die Räder der Wagen und die Innerseite der Schiene perfekt sauber sein.

ATTENTION: To avoid noises and vibrations during the door's sliding, the wheels of the carriages and the inside of the rail must be perfectly clean.

ATENCIÓN: Para evitar ruidos y vibraciones durante el deslizamiento de las puertas, las ruedas de los carrillos y el interior de la guía tienen que ser perfectamente limpios.

Configurazione 1 anta scorrevole / 1 sliding door configuration

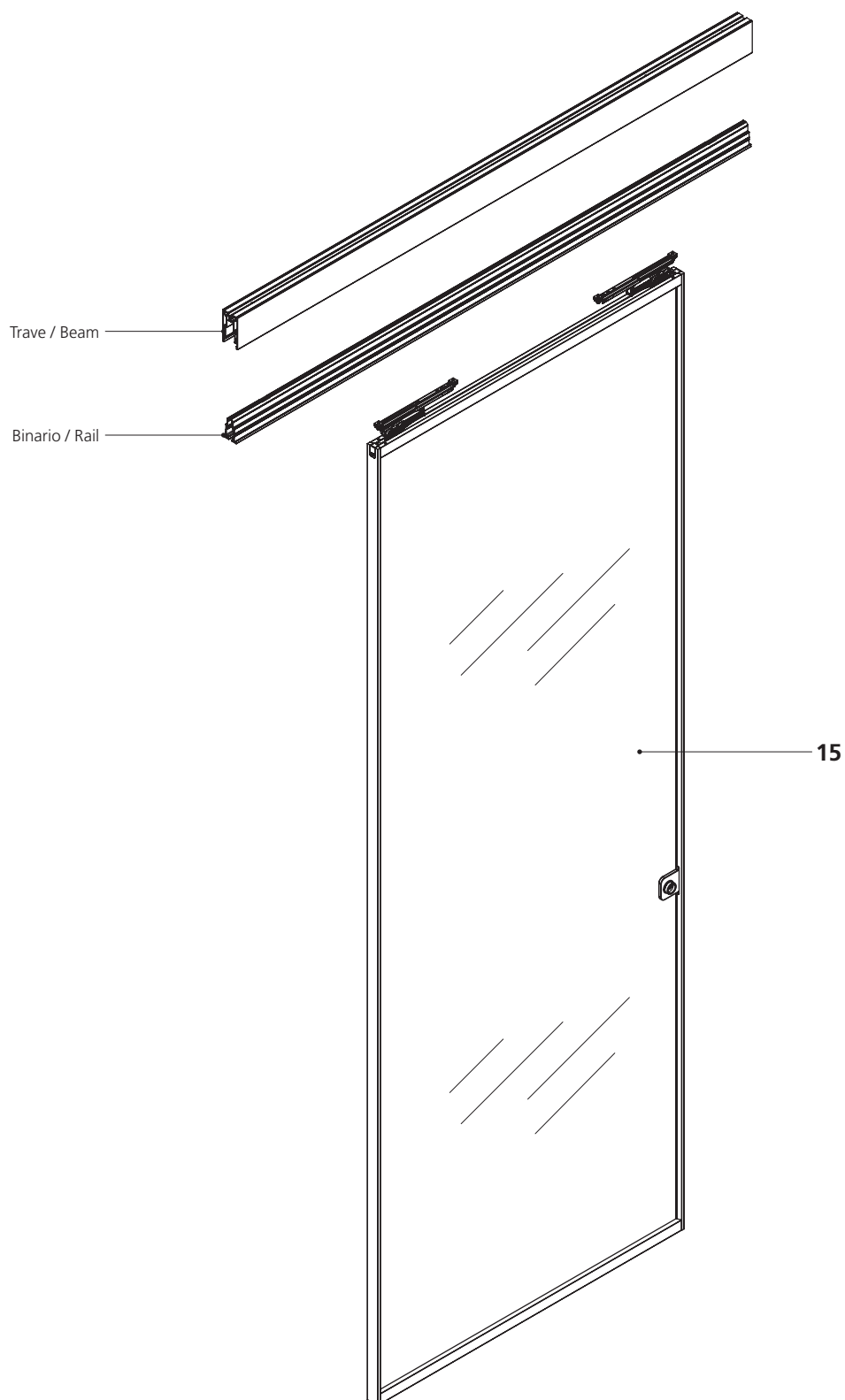

Installazione ante / Doors installation

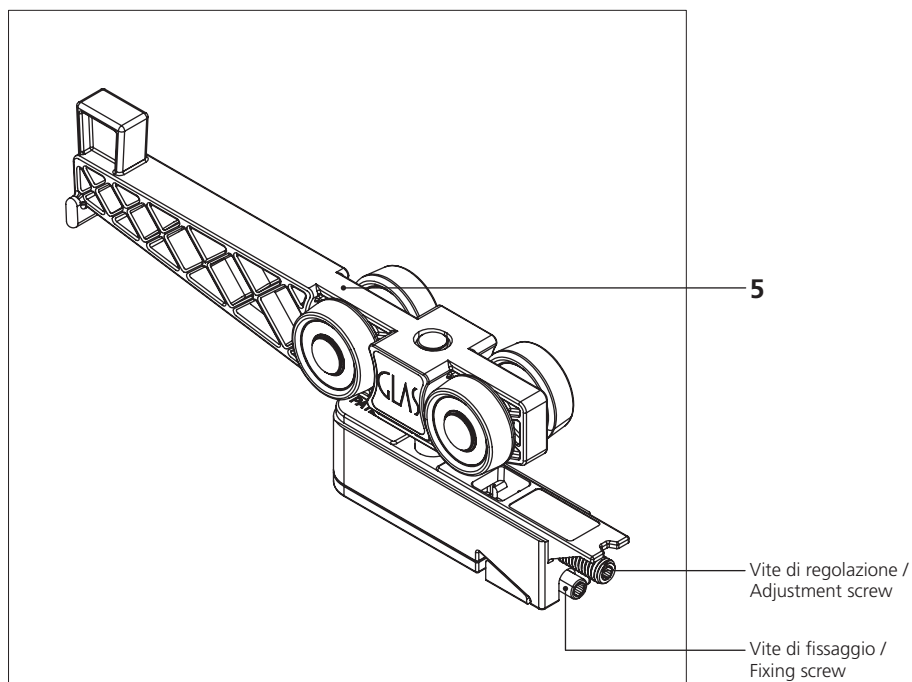

- 1b. Carter di finitura / Finishing case
- 2. Trave / Beam
- 3. Binario / Rail
- 5. Carrello / Carriage
- 6. Rallentatore / Slow motion device
- 15. Anta mobile / Sliding door
- 16. Perno a pavimento / Floor pivot
- 17. Tappo con logo / Closure cap with logo

5

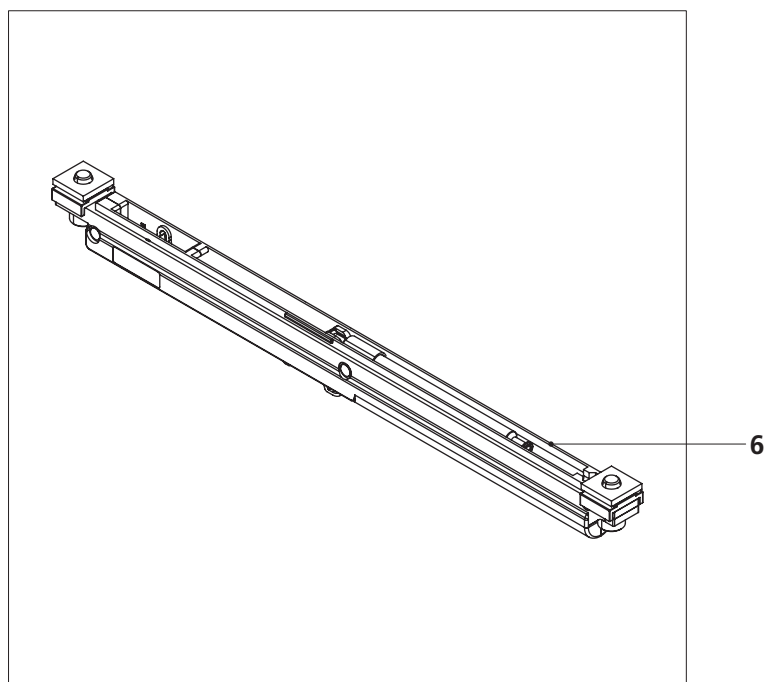
Vite di regolazione /
Adjustment screwVite di fissaggio /
Fixing screw

6



ATTENZIONE: Prima di proseguire con il montaggio, leggere attentamente tutto il fascicolo delle istruzioni. /

WARNING: Before proceeding with the installation, read carefully all the installation manual.

Simbologia e strumenti di montaggio / Symbology and assembly tools



Fare attenzione/
Pay attention



Allineare/
Align

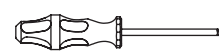

Cacciavite a croce/
Crosshead screwdriver



Avvicinare - togliere/
Bring closer - Remove



Avvitare-regolare/
Screw-adjust



Chiave a brugola/
Hex key



In squadra/
At right angle



Inserisci/
Insert



Quota/
Level

Installazione ante / Doors installation

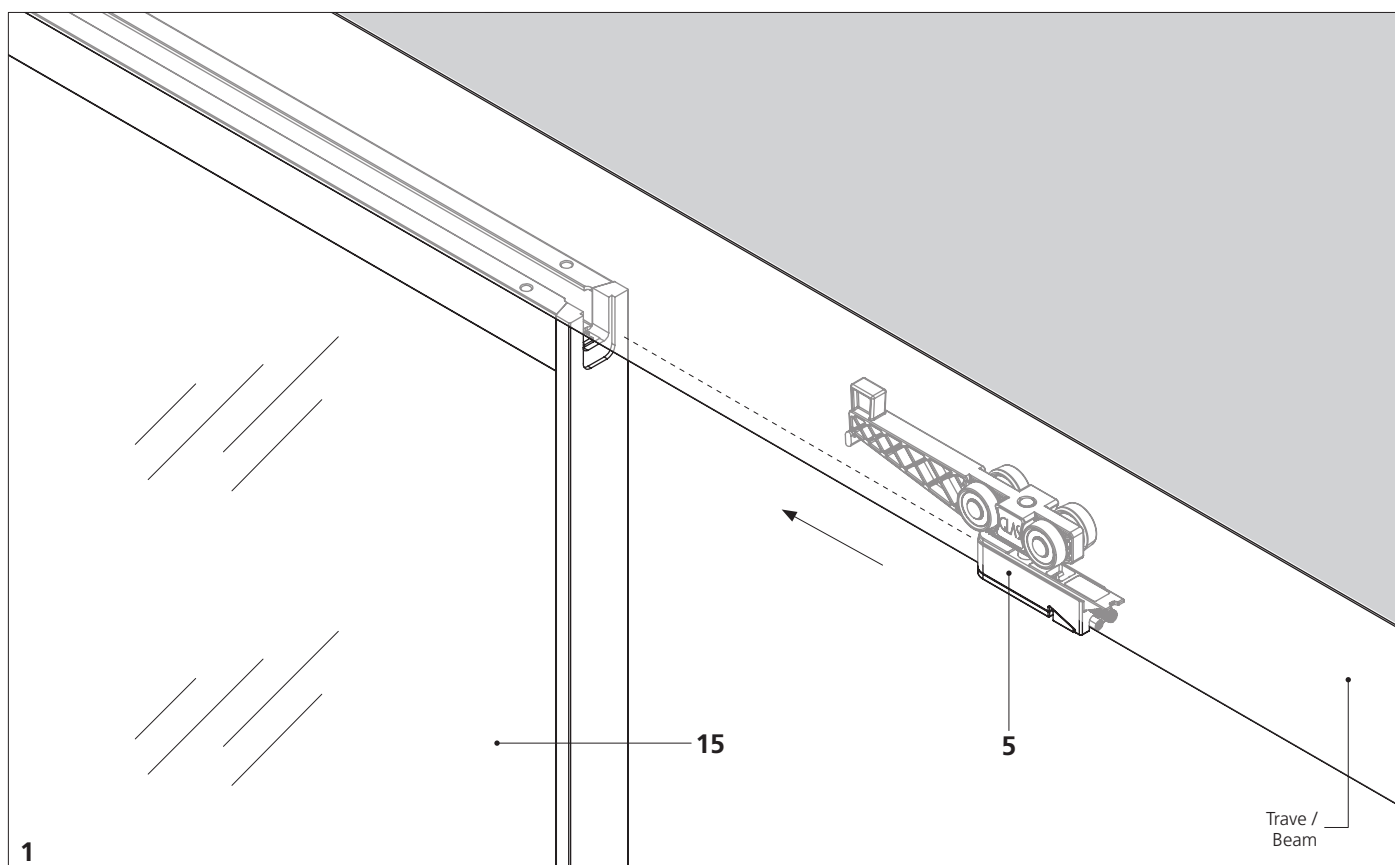

1. Agganciare l'anta ai carrelli.
1. Hook the door to the sliding carriages.

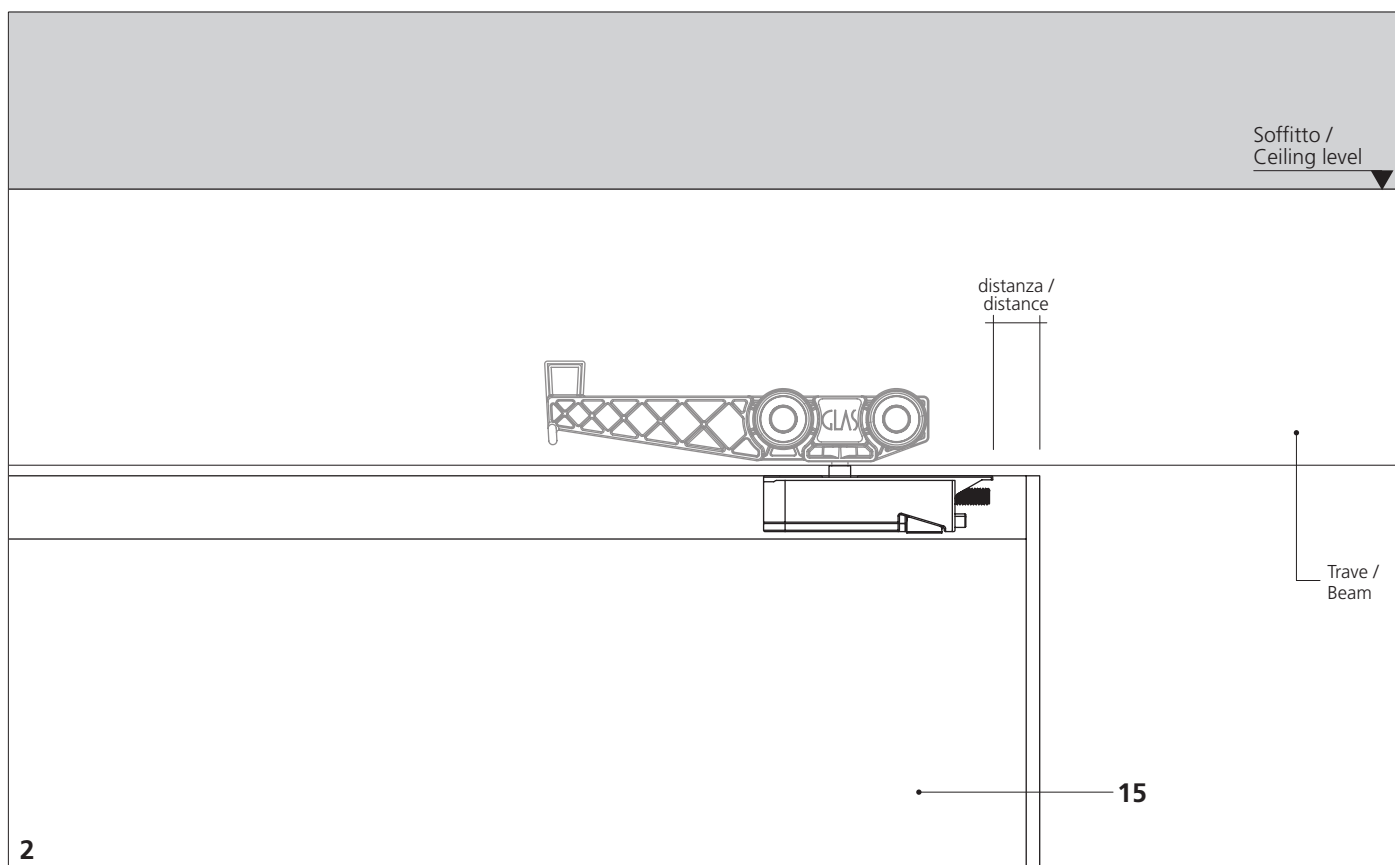

2. La lavorazione presente sul traverso dell'anta identifica la posizione del carrello rispetto al bordo dell'anta stessa.
2. Machining on the door's crosspiece identifies the position of the carriage in relation to the door's edge.

Installazione ante / Doors installation

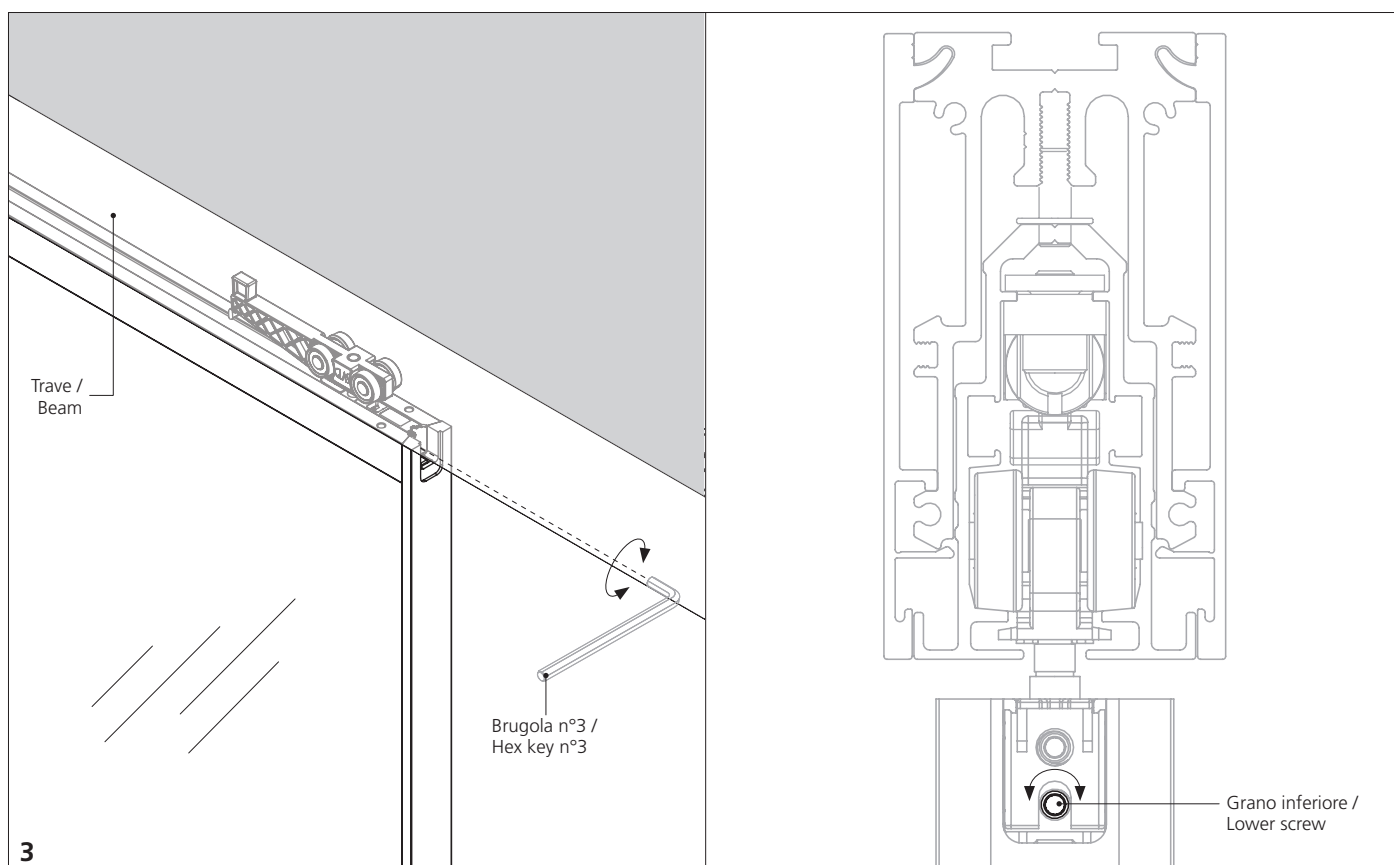

3. Avvitare il grano inferiore per bloccare il carrello. Ripetere i passaggi da n°1 a 3 per tutte le ante.
 3. Screw the lower grain to block the carriage. Repeat the steps from n° 1 to 3 for all doors.

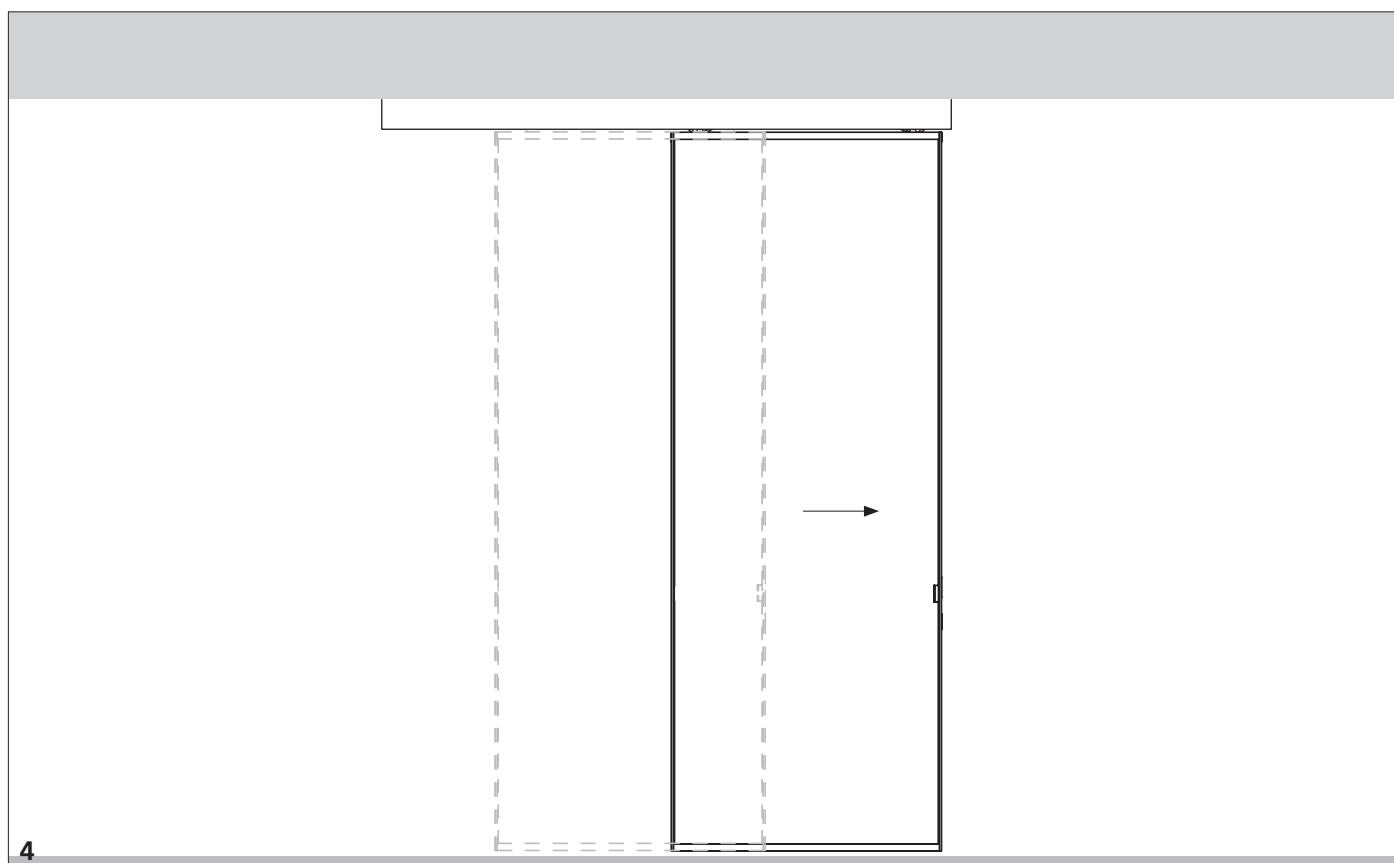

4. Portare l'anta nella posizione di chiusura.
 4. Place the door in the closing position.

Installazione ante / Doors installation

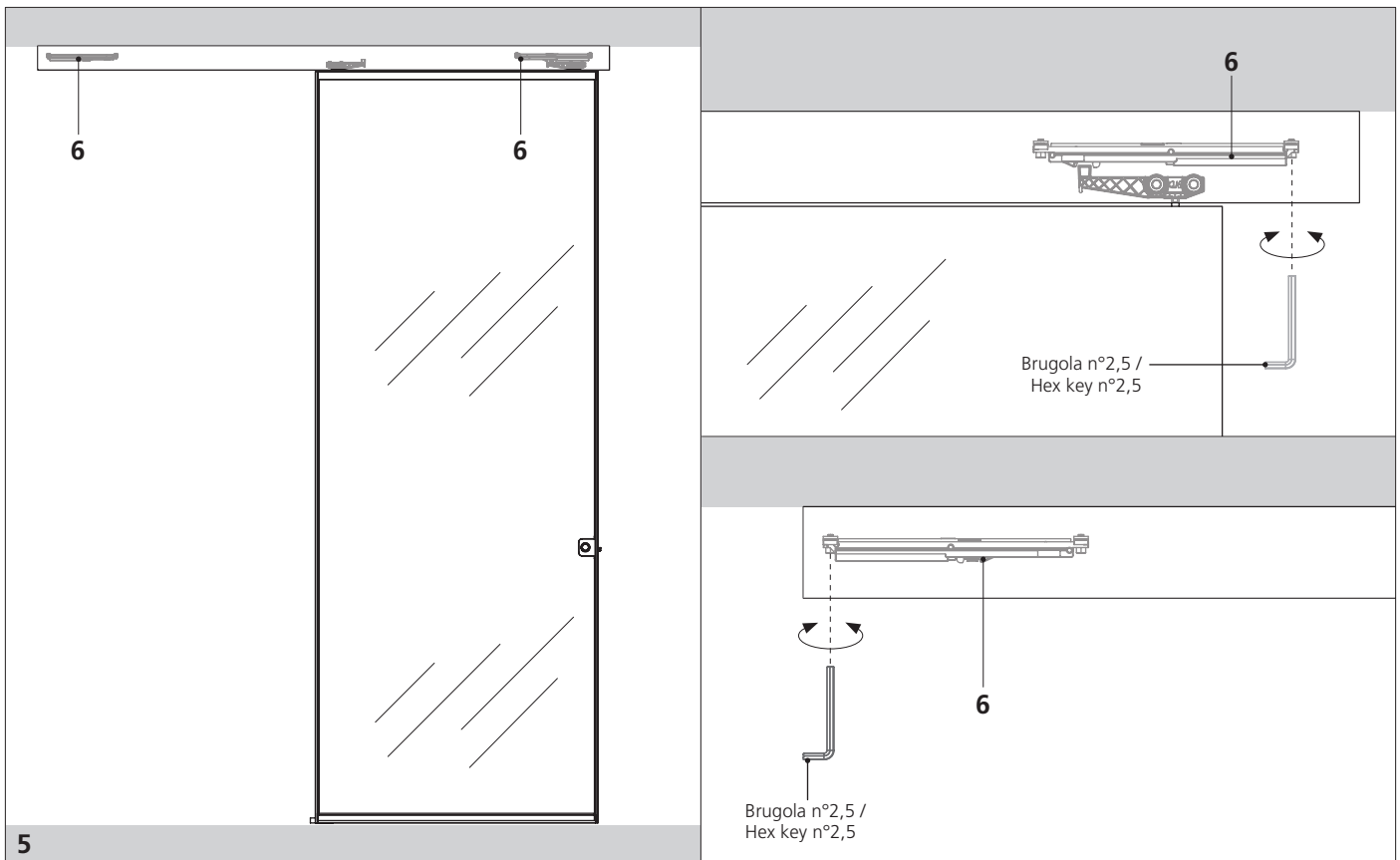

5. Posizionare i rallentatori alla giusta distanza e stringere le viti di fissaggio.
5. Place the slow motions in the correct position and tighten the fixing screws.

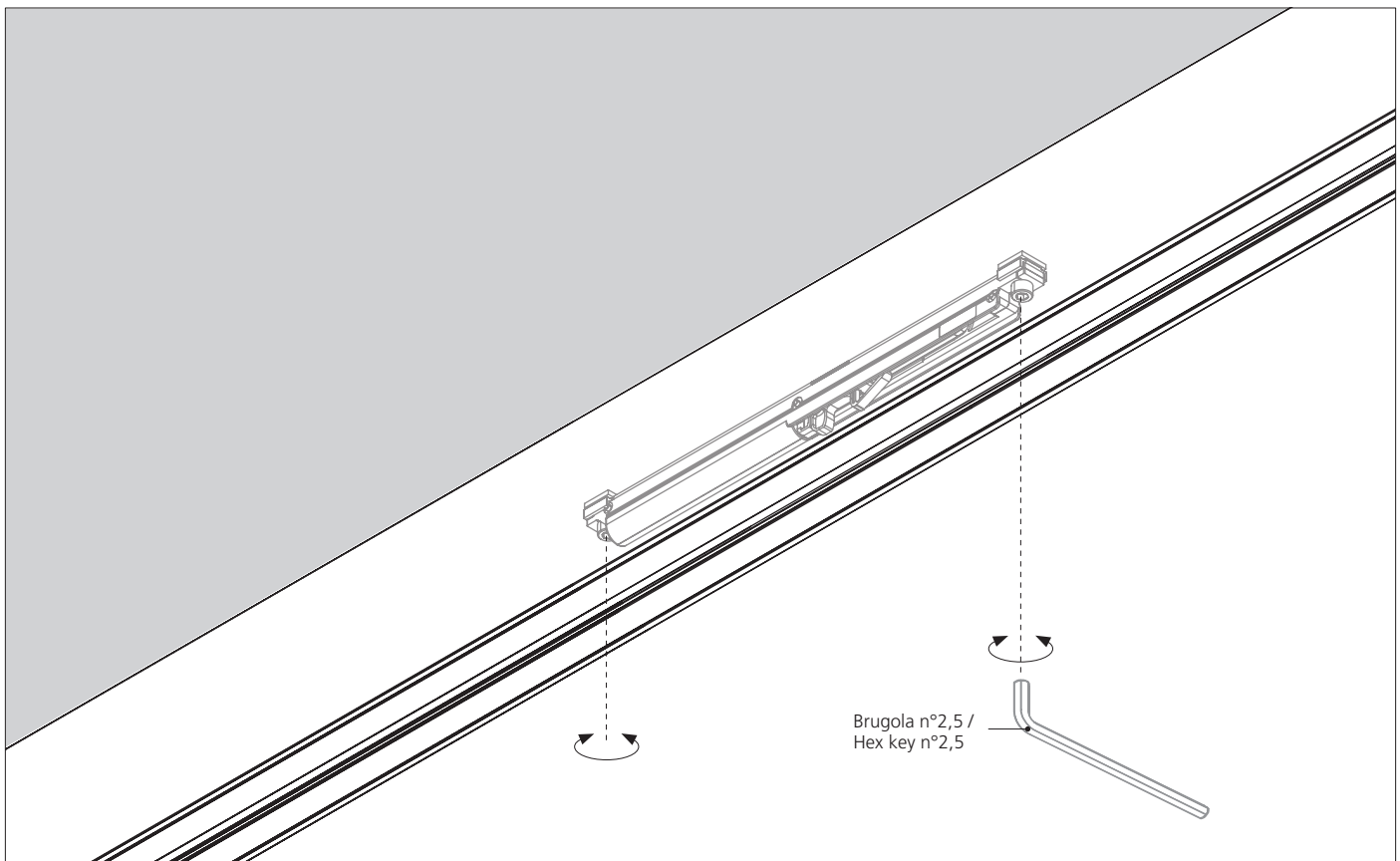

Installazione ante / Doors installation

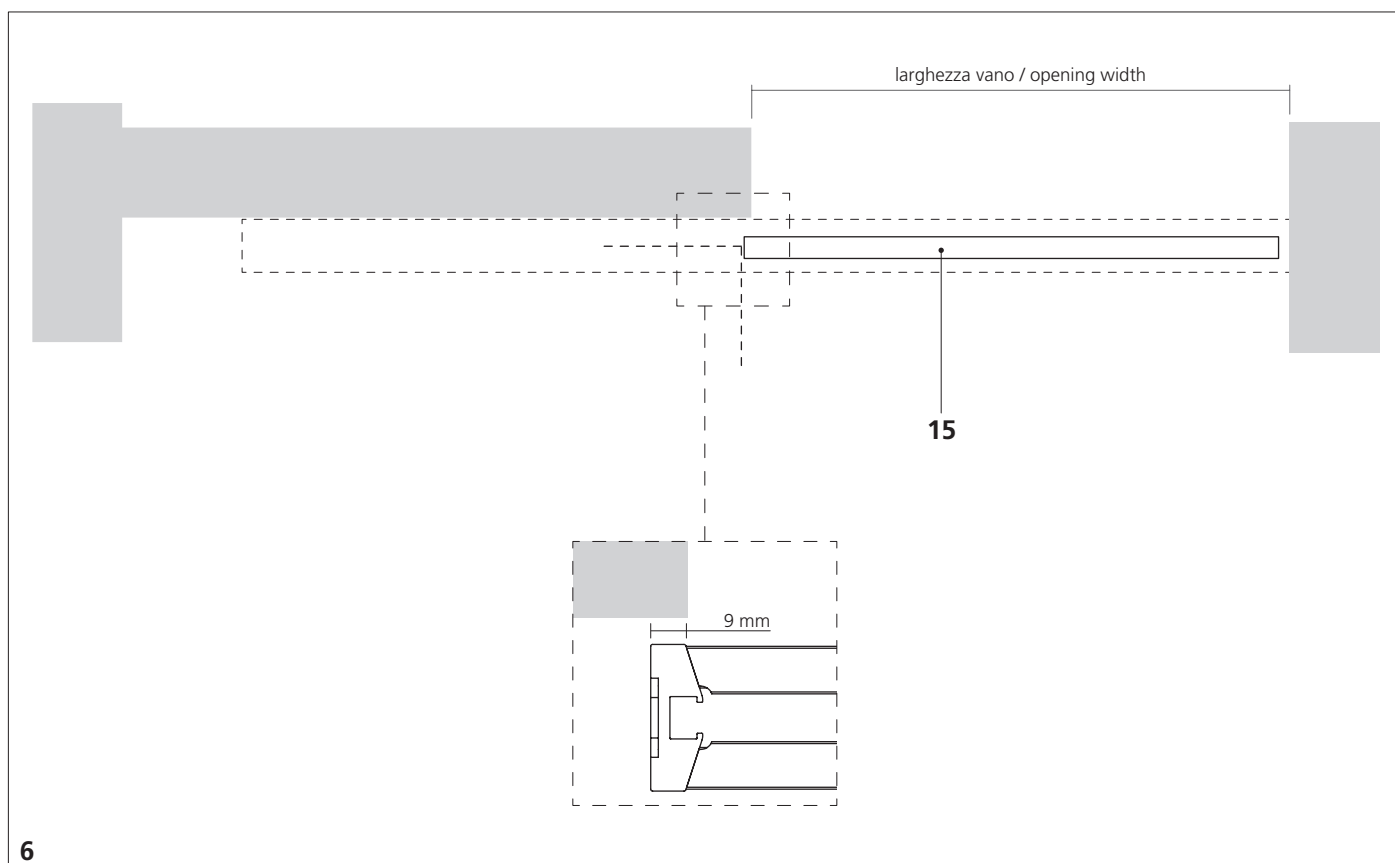

6

6. Segnare la posizione dell'anta per posizionare il perno a pavimento.
6. Mark the door position in order to place the floor pivot.

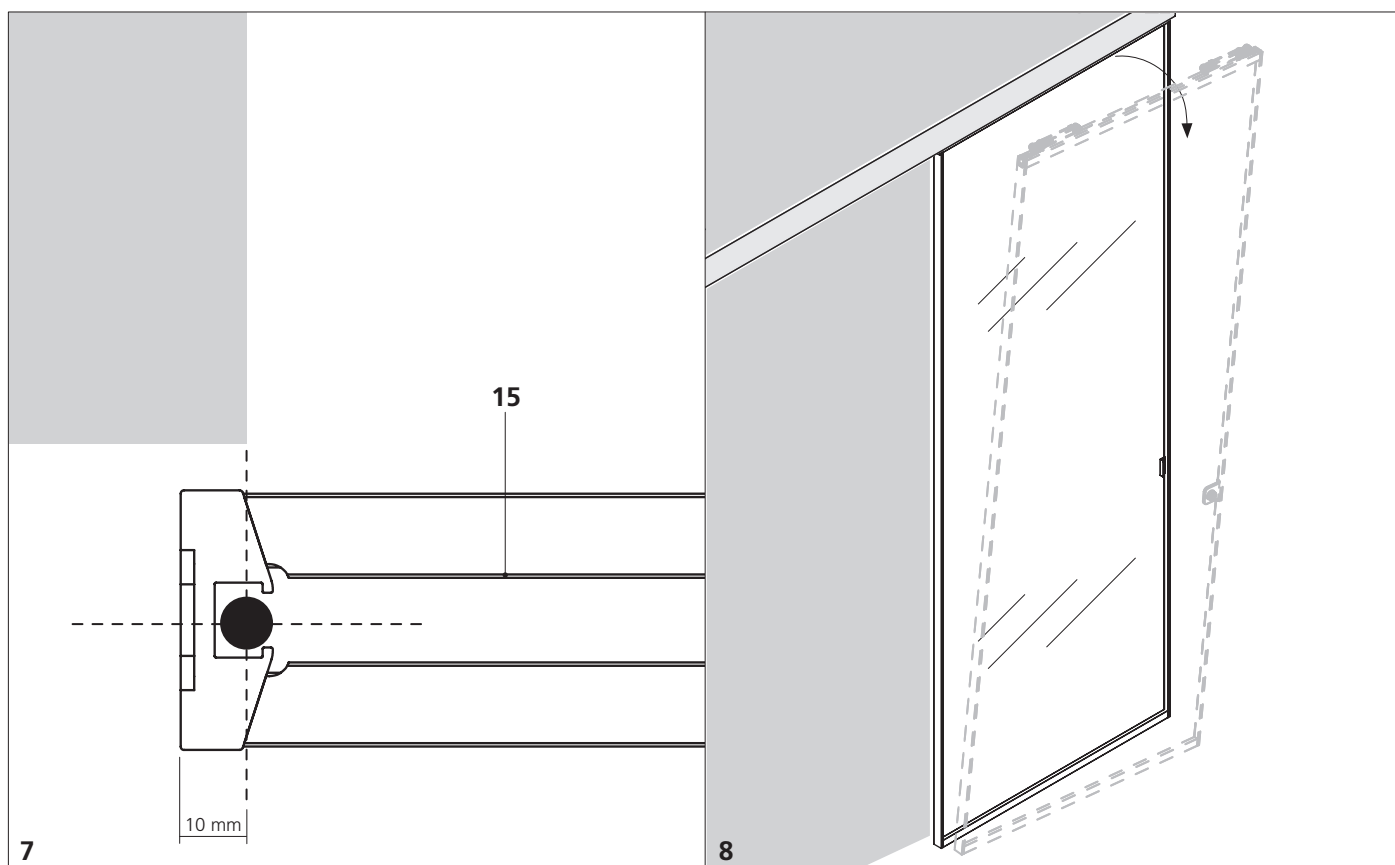

7

8

7. Il perno deve essere posizionato in centro all'anta e a 10 mm dal bordo posteriore. / 8. Svitare i carrelli e togliere l'anta.
7. The floor pivot has to be placed in the middle of the door and at 10mm from the rear edge. / 8. Unscrew the carriages and remove the door.

Installazione ante / Doors installation

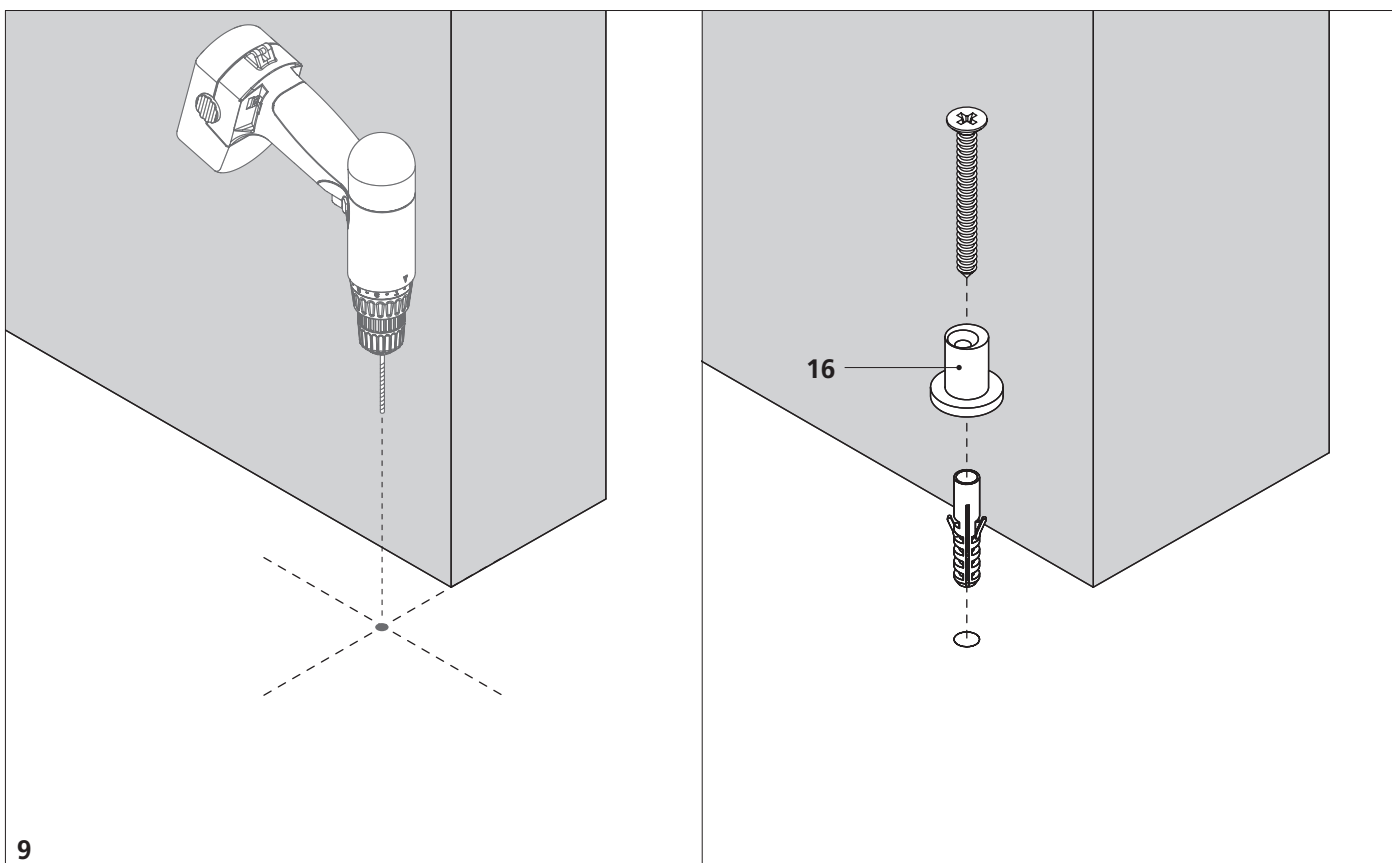

9. Forare e fissare il perno a pavimento.
9. Drill and fix the floor pivot to the floor.

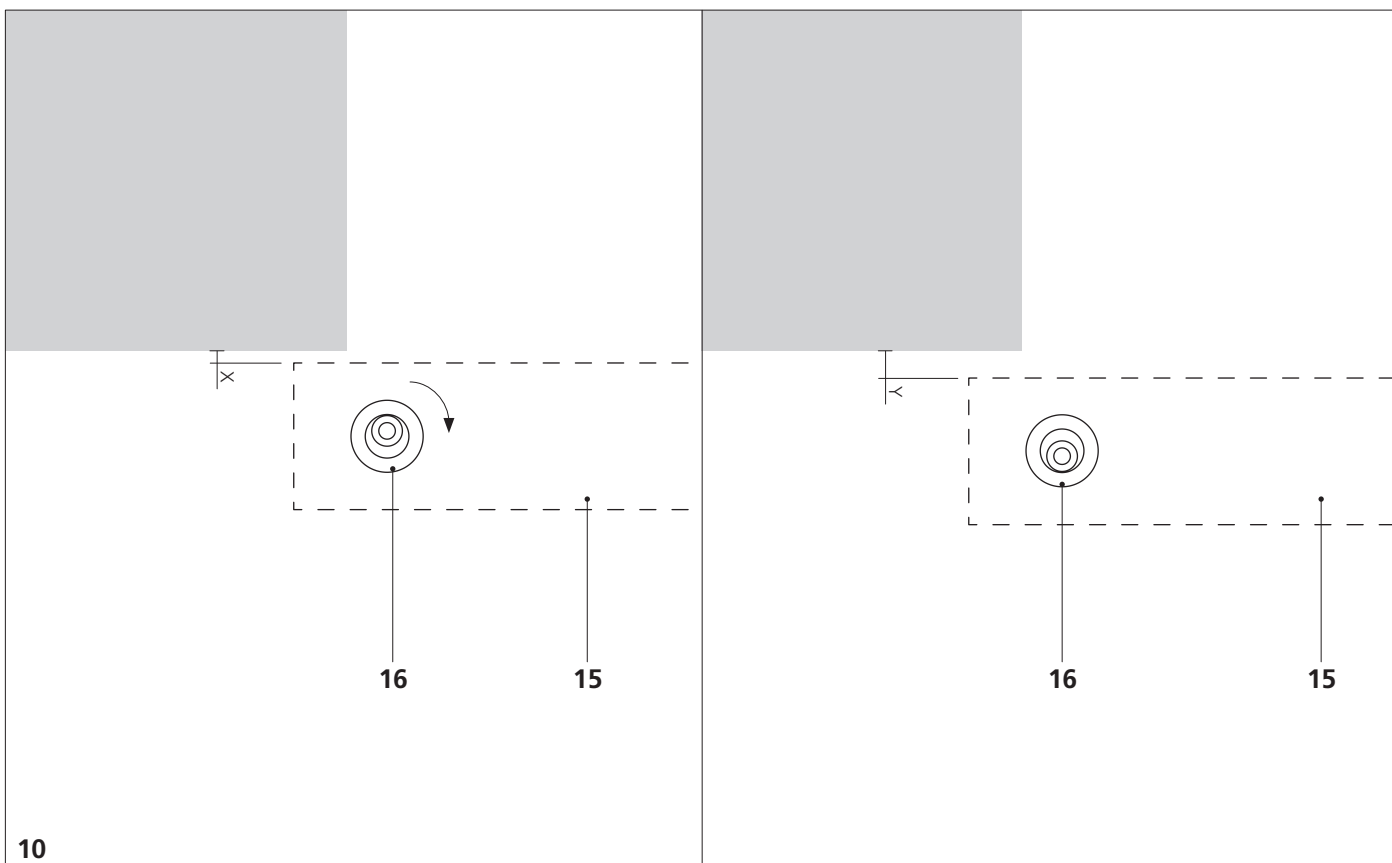

10. Se necessario regolare il perno a pavimento tramite il foro eccentrico.
10. If necessary, adjust the floor pivot through the eccentric hole.

Installazione ante / Doors installation

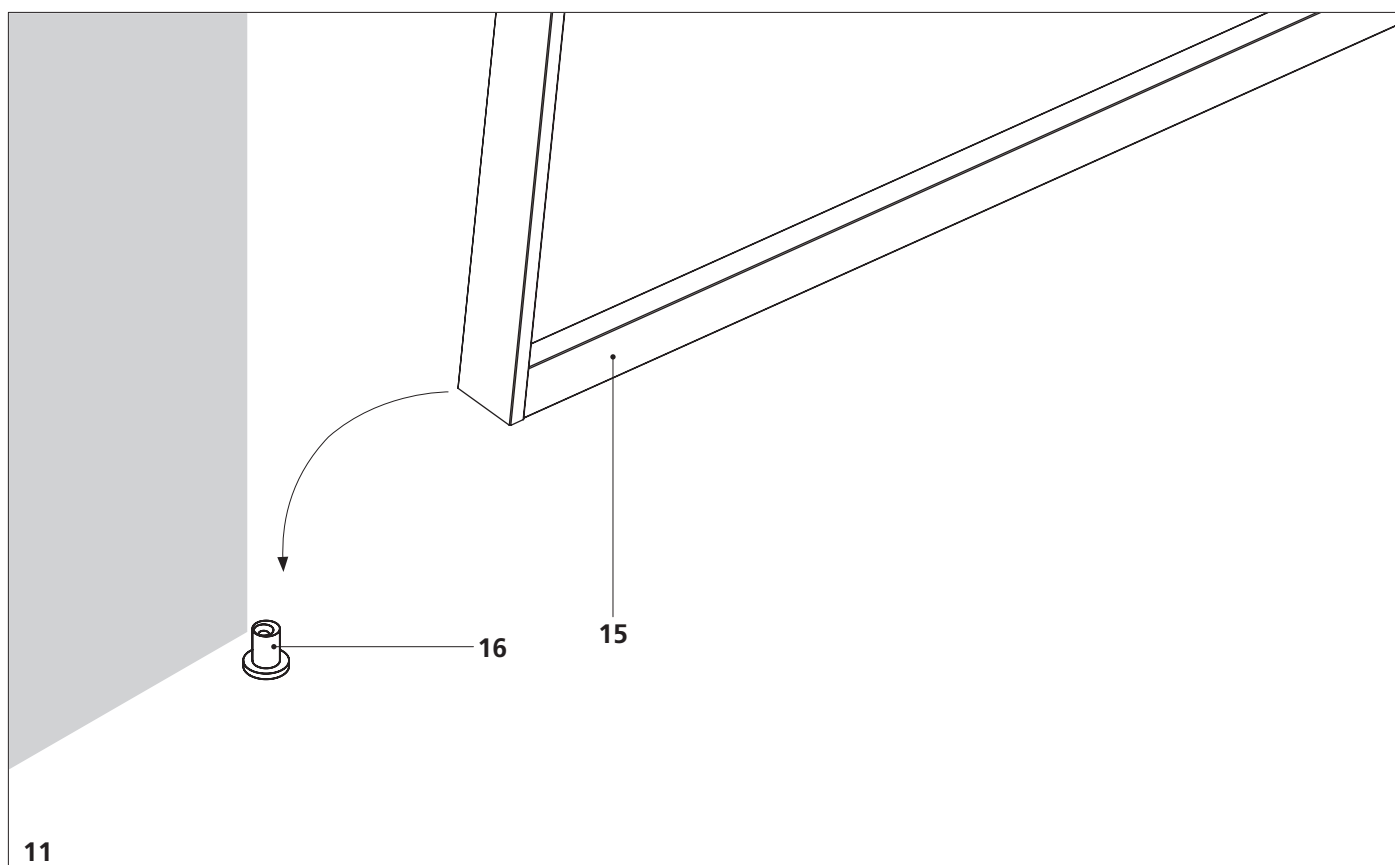

11. Infilare l'anta sopra al perno a pavimento.
11. Insert the door on the floor pivot.

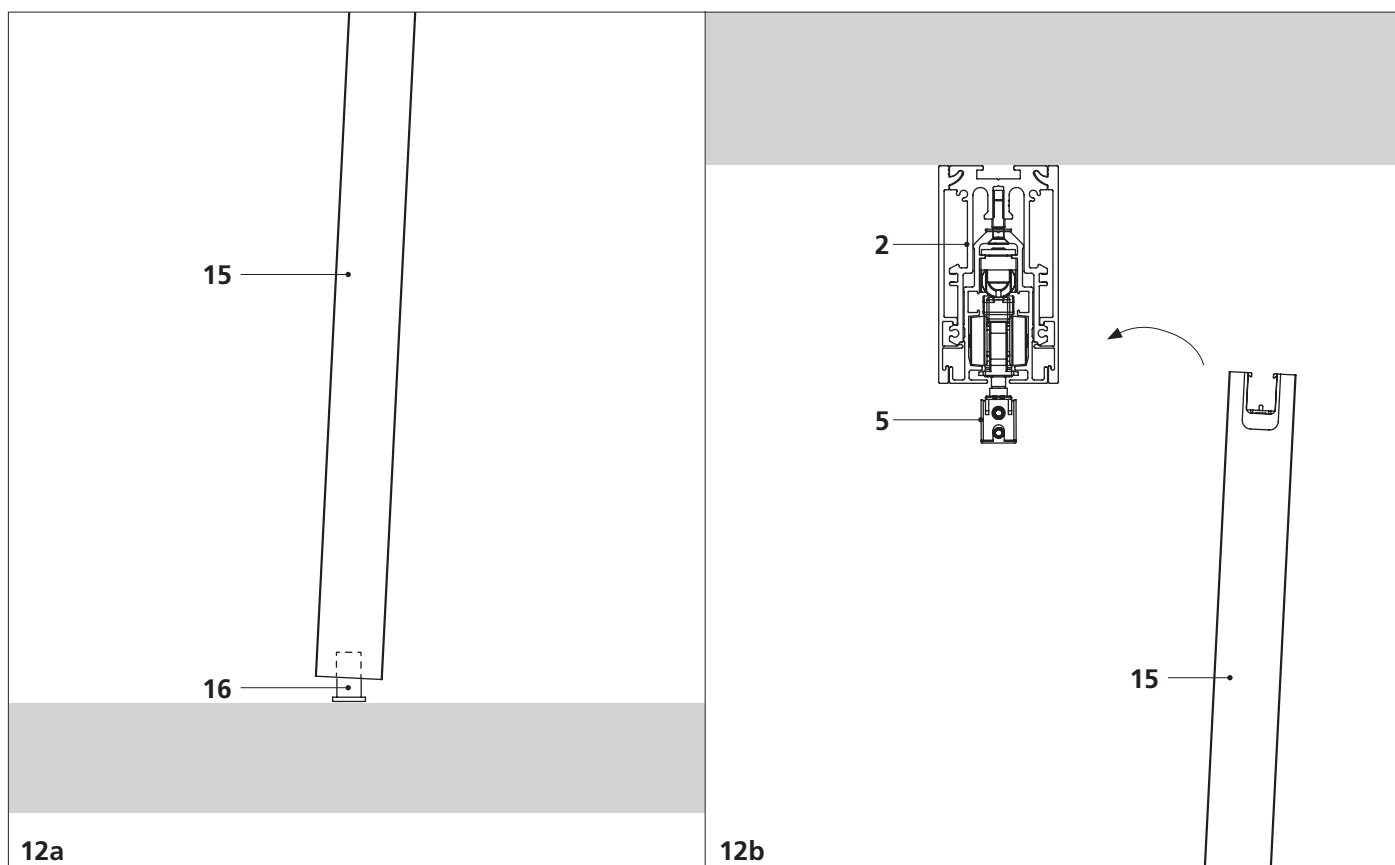

12. Calzare l'anta sul perno, sollevarla e avvicinarla ai carrelli inseriti nel binario.
12. Insert the door on the pivot, lift it and bring it close to the carriages inserted in the beam.

Installazione ante / Doors installation

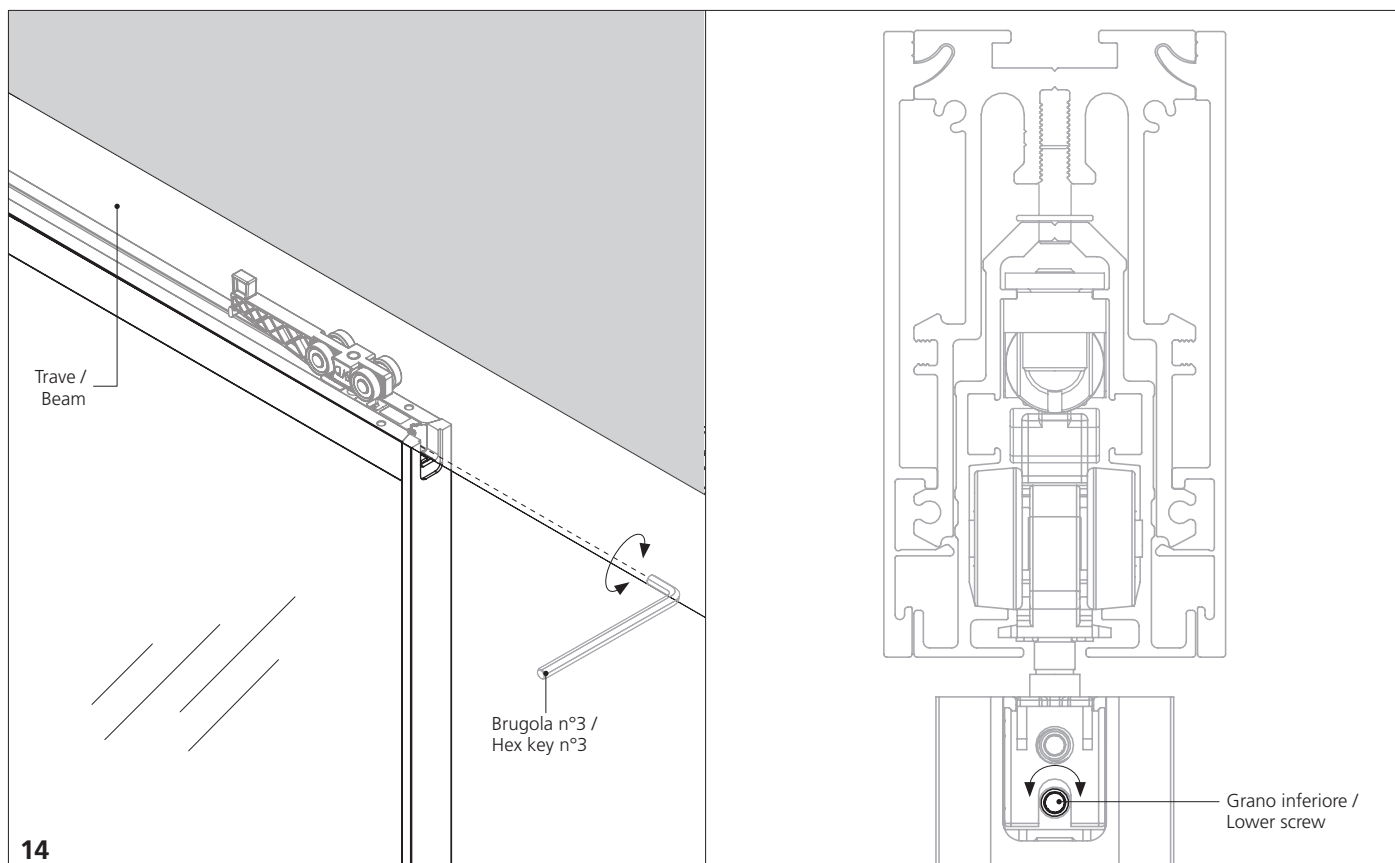

14. Avvitare il grano inferiore per bloccare il carrello.
14. Screw the lower grain to lock the carriage.

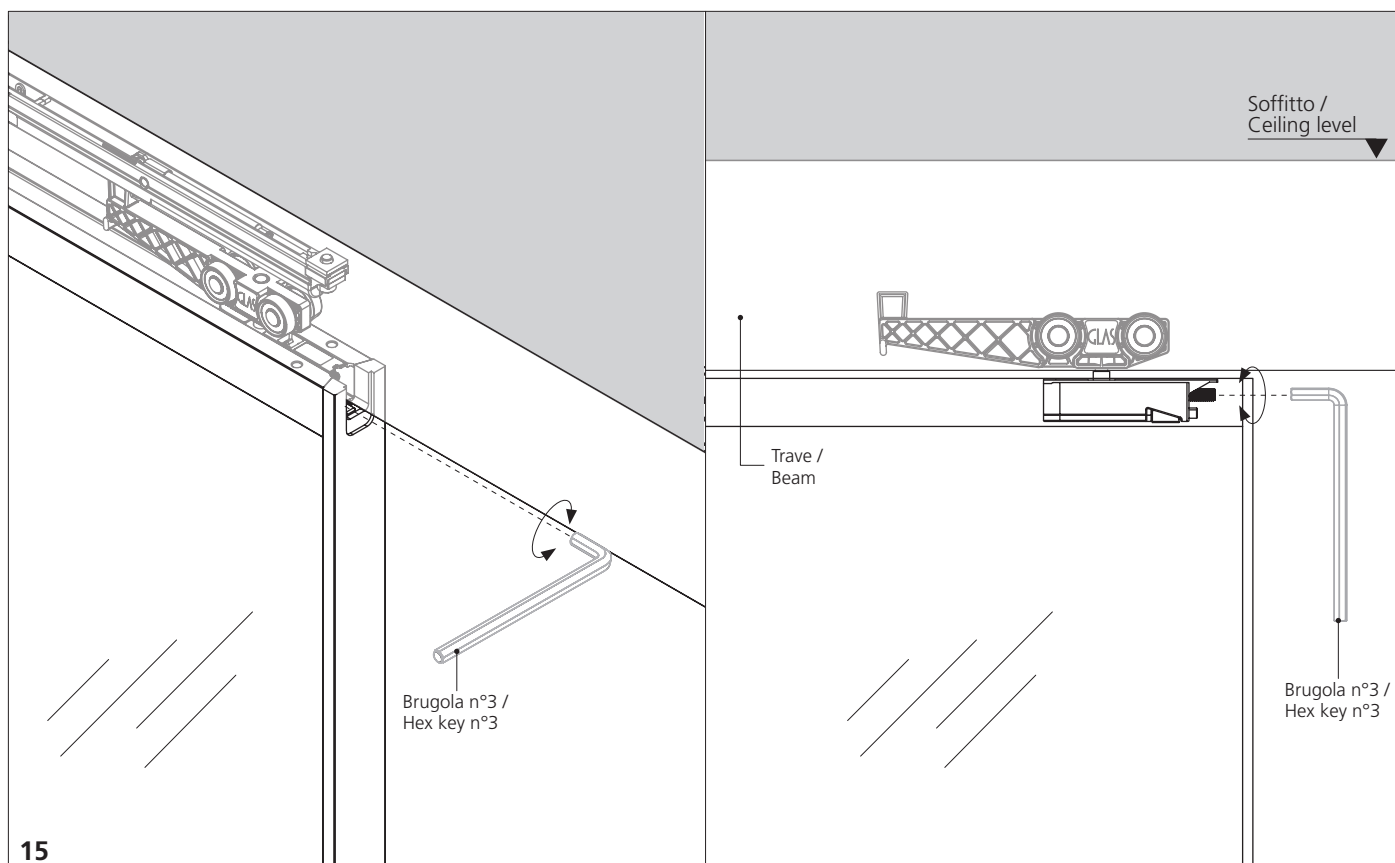

15. Per una regolazione millimetrica dell'anta, agire sulla vite superiore presente nel carrello di scorrimento.
15. To adjust the door millimetrically, act on the upper screw placed in the sliding carriage.

Installazione ante / Doors installation

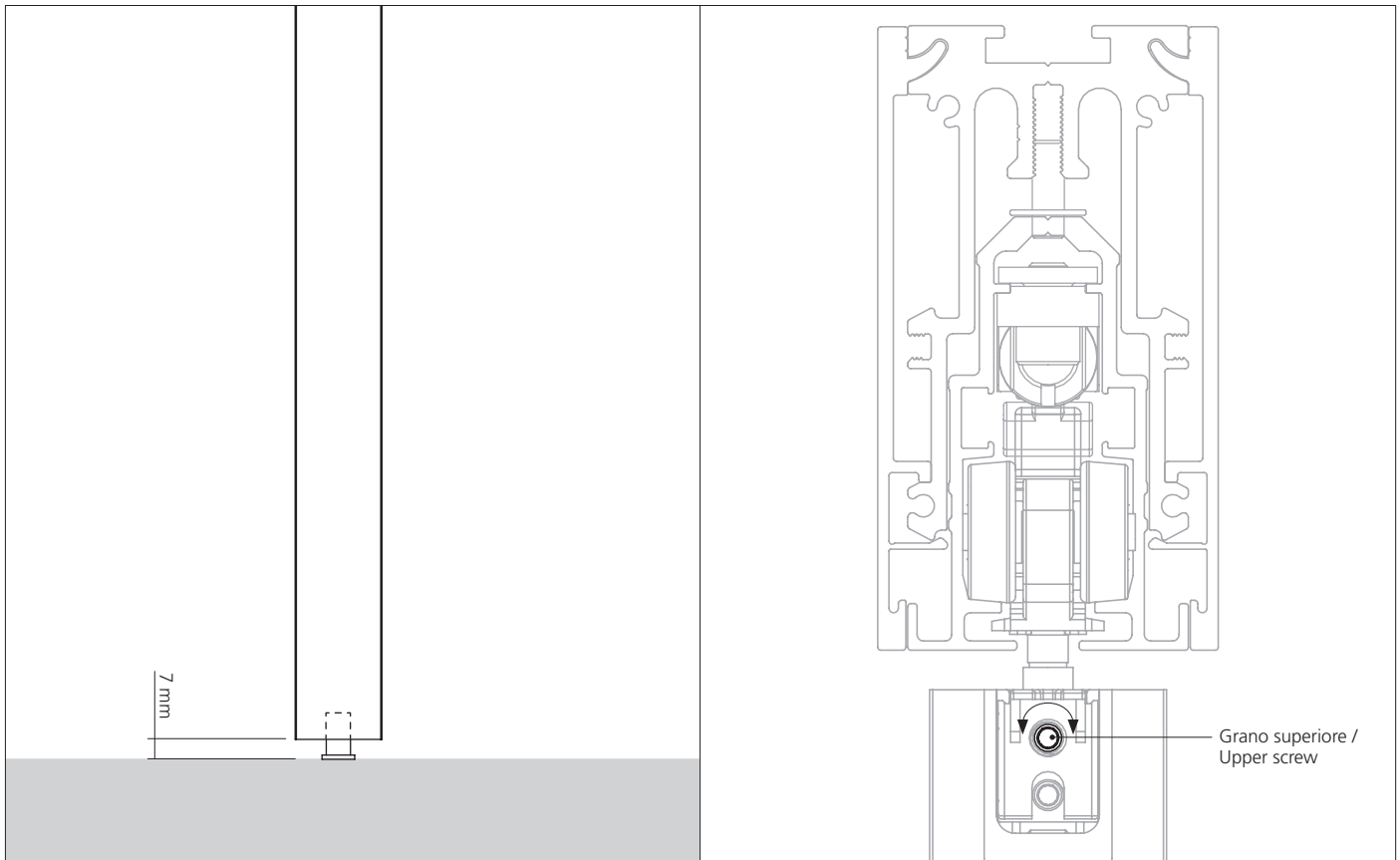

Misura ideale per lo scorrimento dell'anta.
Ideal measure for the door sliding.

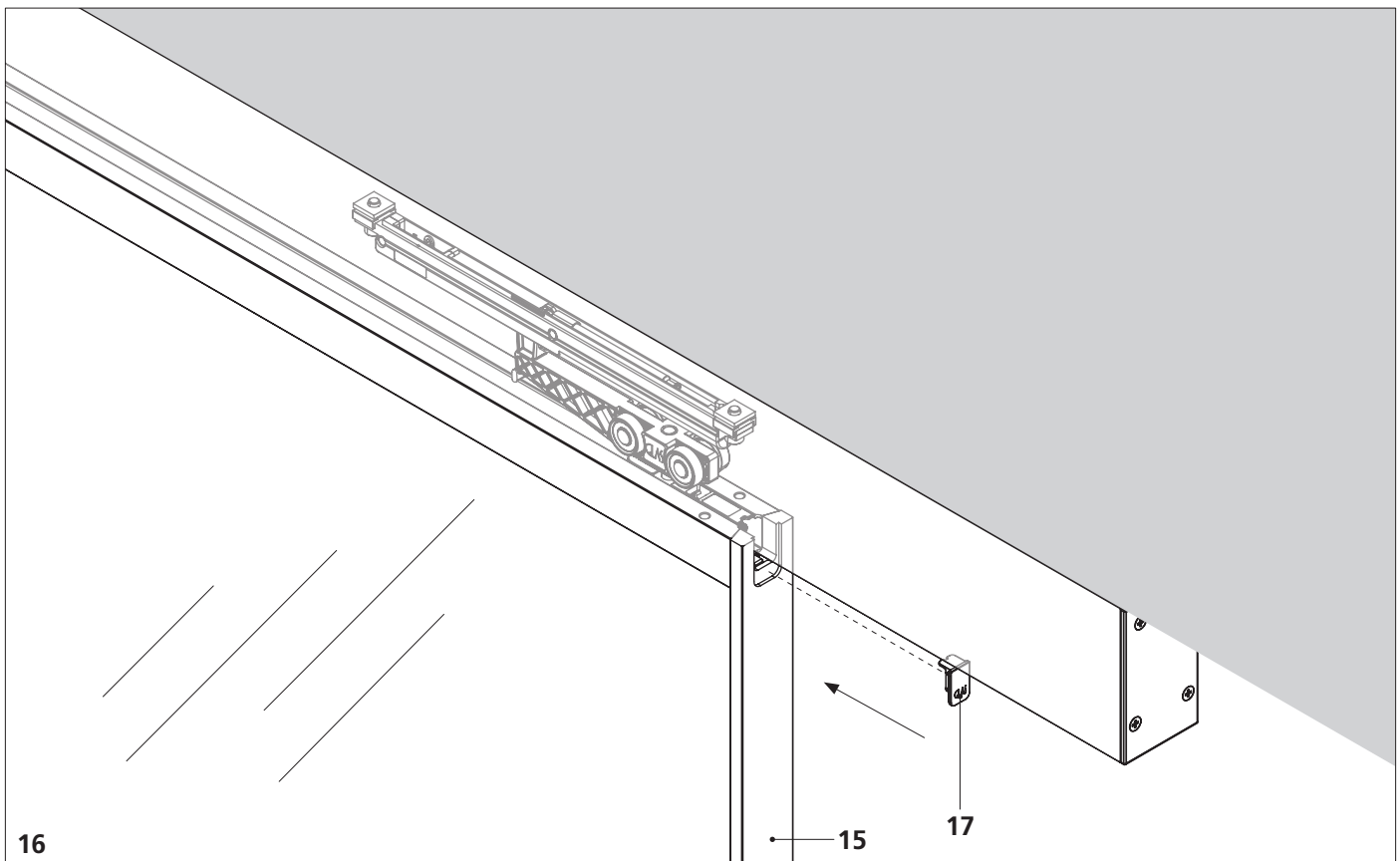

16. Posizionare a pressione il tappo copri carrello sulle ante.
16. Place the carriage cover cap on the doors by pressing.

Configurazione 4 ante scorrevoli / 4 sliding doors configuration

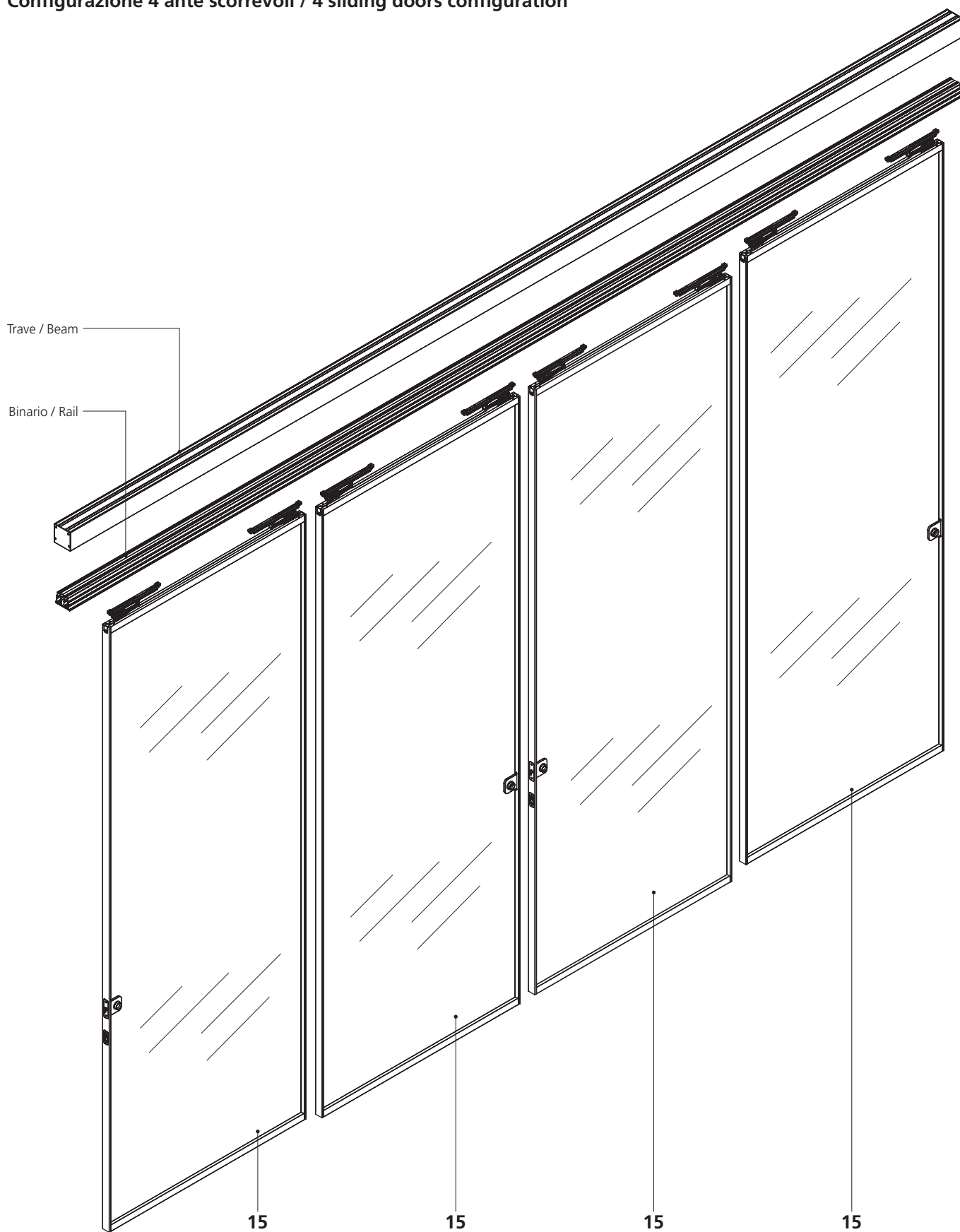

Installazione ante / Doors installation

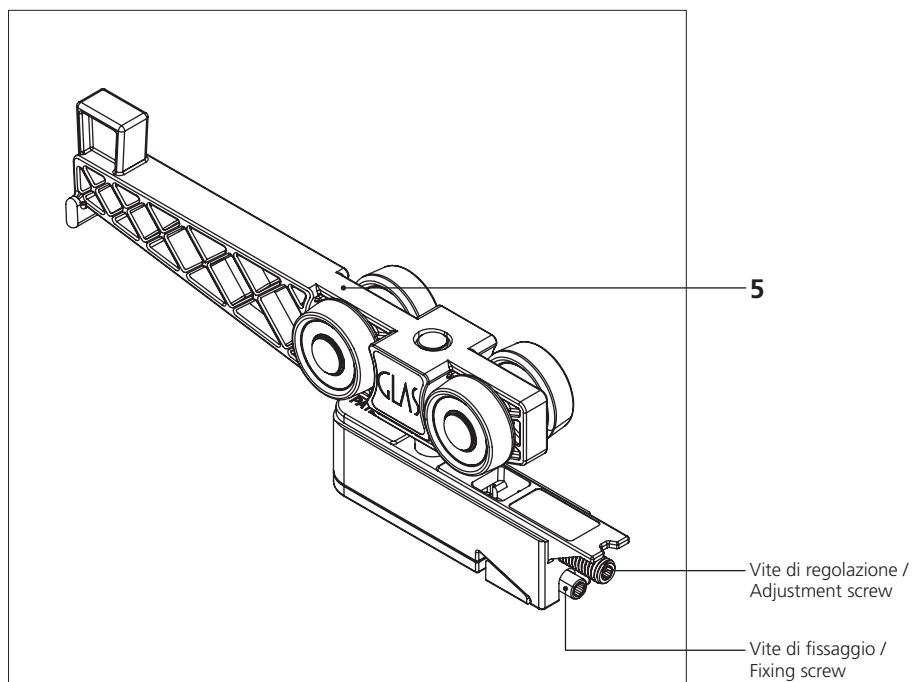

- 1b. Carter di finitura / Finishing case
- 2. Trave / Beam
- 3. Binario / Rail
- 5. Carrello / Carriage
- 6. Rallentatore / Slow motion device
- 15. Anta mobile / Sliding door
- 16. Perno a pavimento / Floor pivot
- 17. Tappo con logo / Closure cap with logo

5

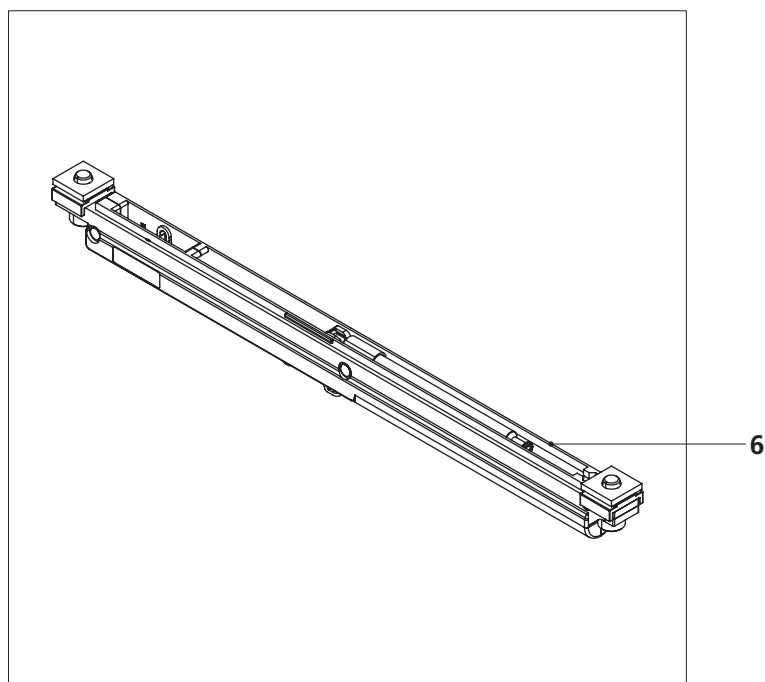
Vite di regolazione /
Adjustment screwVite di fissaggio /
Fixing screw

6



ATTENZIONE: Prima di proseguire con il montaggio, leggere attentamente tutto il fascicolo delle istruzioni. /

WARNING: Before proceeding with the installation, read carefully all the installation manual.

Simbologia e strumenti di montaggio / Symbology and assembly tools



Fare attenzione/
Pay attention



Allineare/
Align

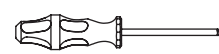

Cacciavite a croce/
Crosshead screwdriver



Avvicinare - togliere/
Bring closer - Remove



Avvitare-regolare/
Screw-adjust



Chiave a brugola/
Hex key



In squadra/
At right angle



Inserisci/
Insert



Quota/
Level

Installazione ante / Doors installation

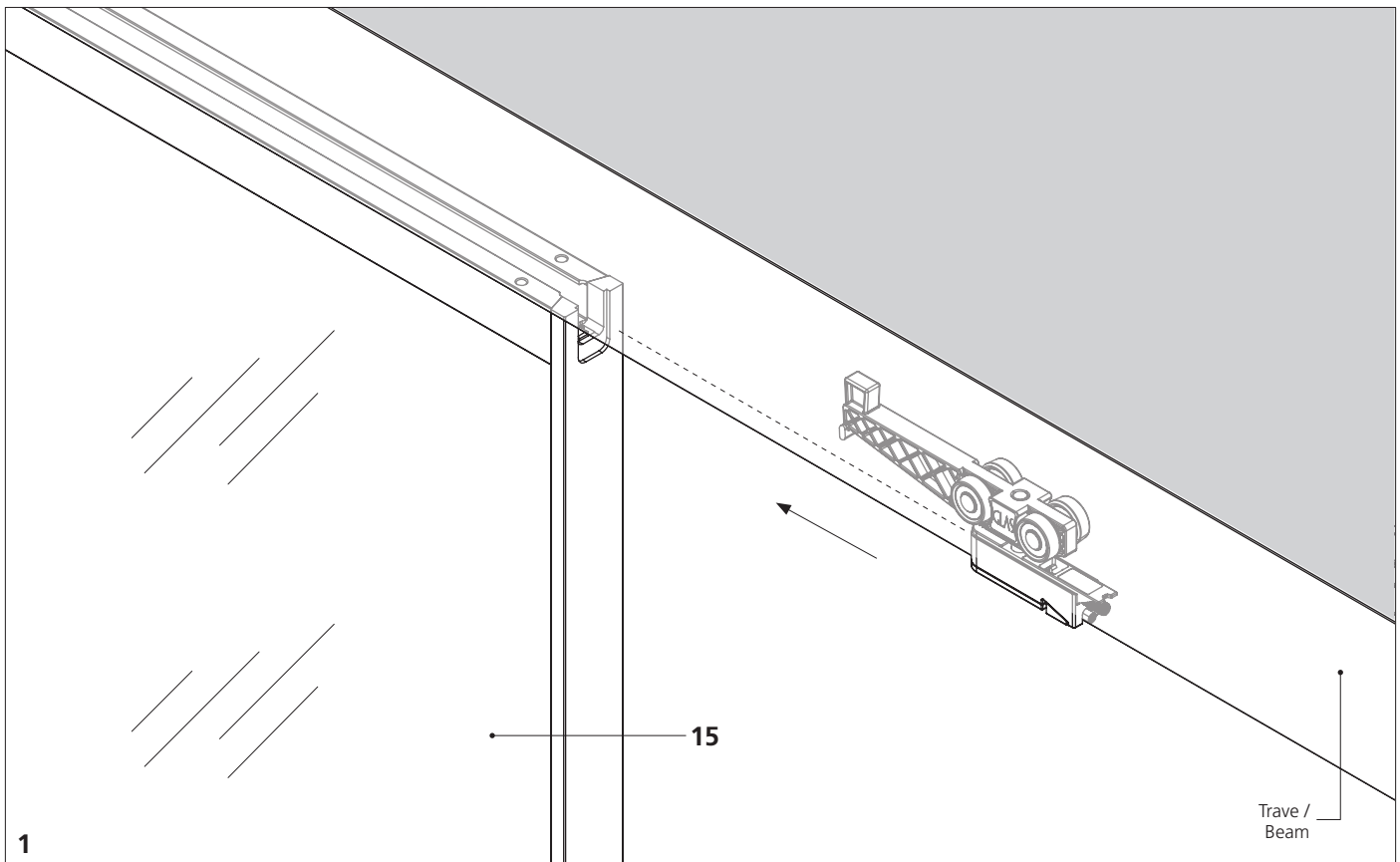

- 1. Agganciare l'anta ai carrelli.**
1. Hook the door to the sliding carriages.

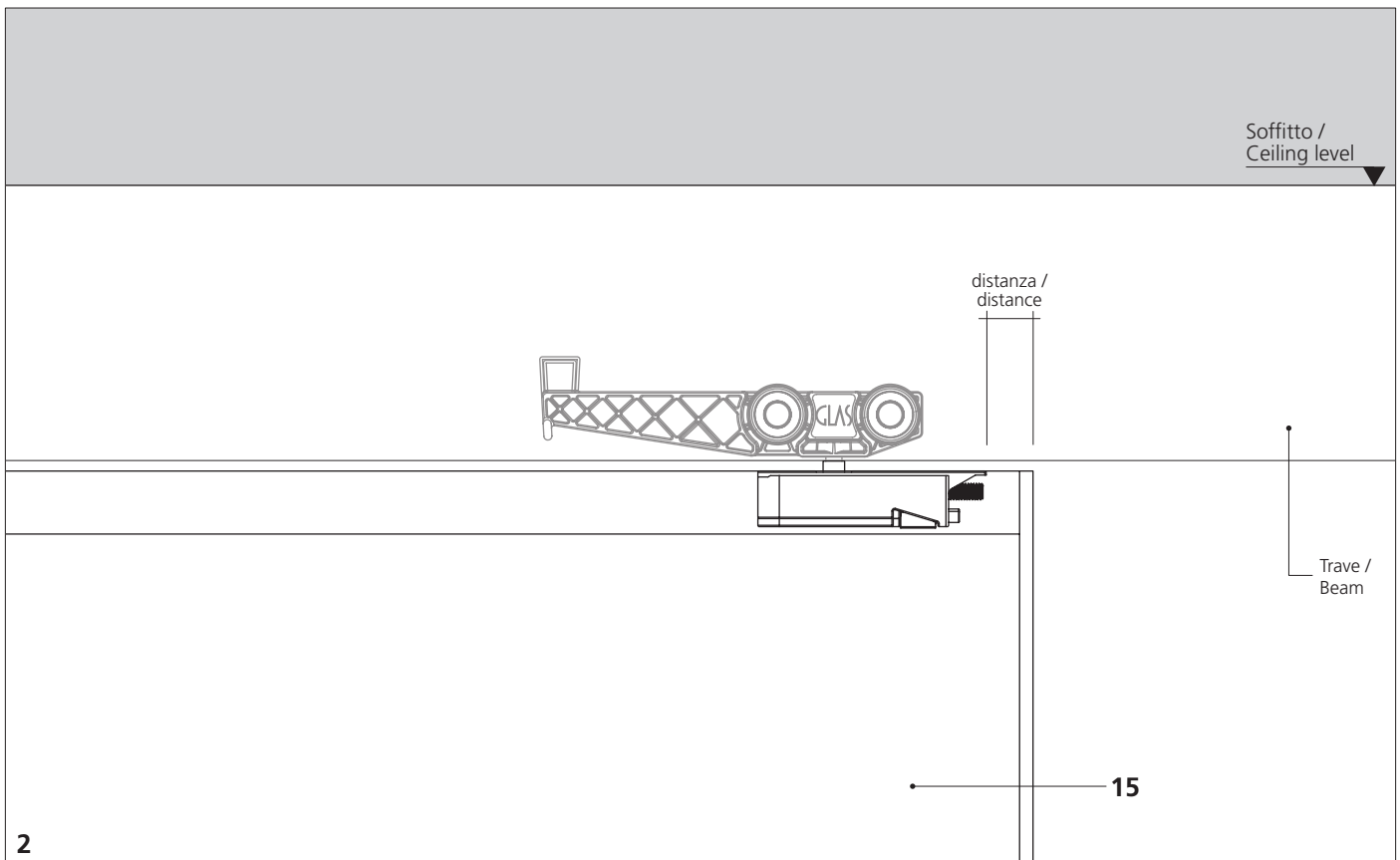

- 2. La lavorazione presente sul traverso dell'anta identifica la posizione del carrello rispetto al bordo dell'anta stessa.**
2. Machining on the door's crosspiece identifies the position of the carriage in relation to the door's edge.

Installazione ante / Doors installation

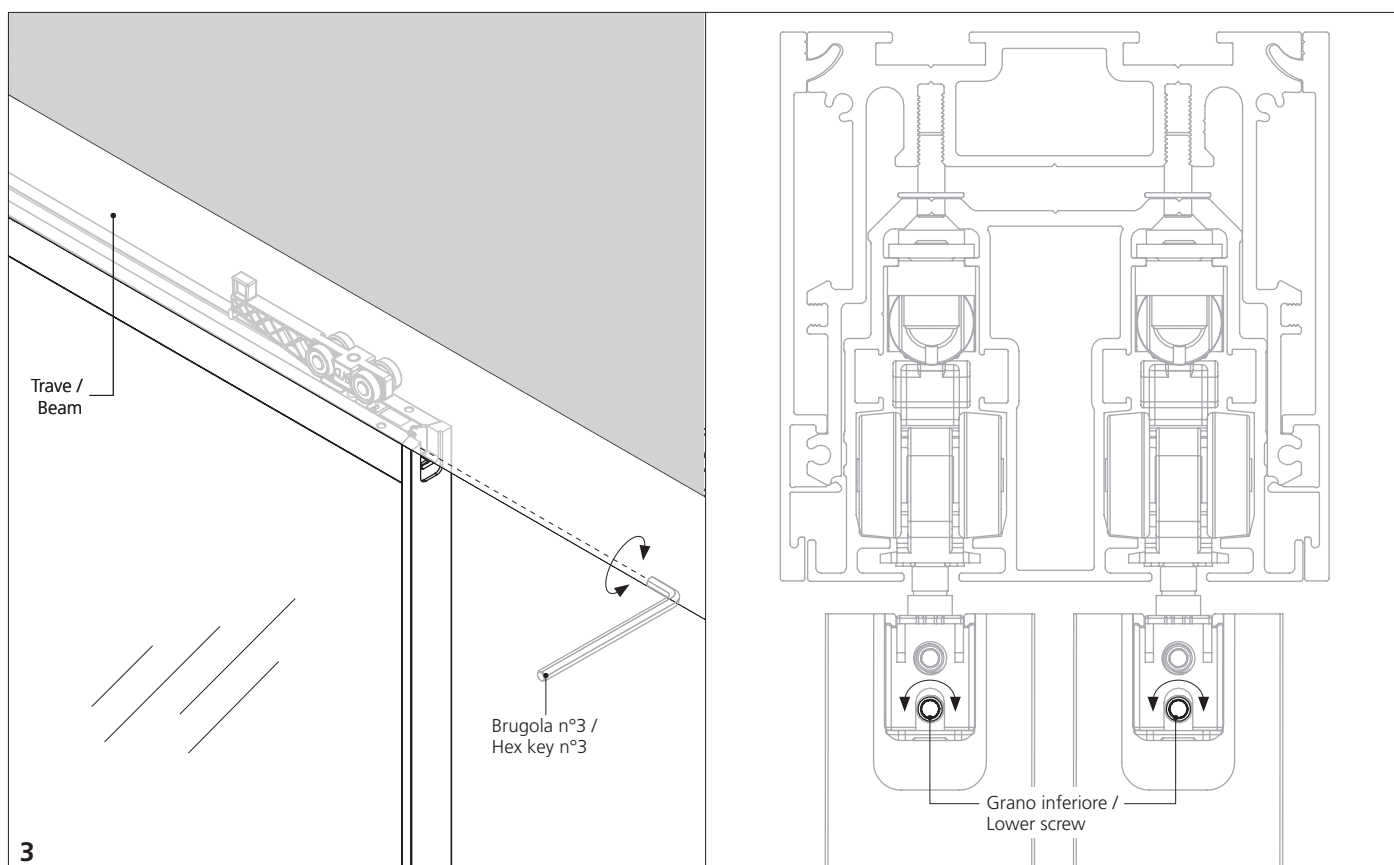

3. Avvitare il grano inferiore per bloccare il carrello. Ripetere i passaggi da n°1 a 3 per tutte le ante.
3. Screw the lower grain to block the carriage. Repeat the steps from n° 1 to 3 for all doors.

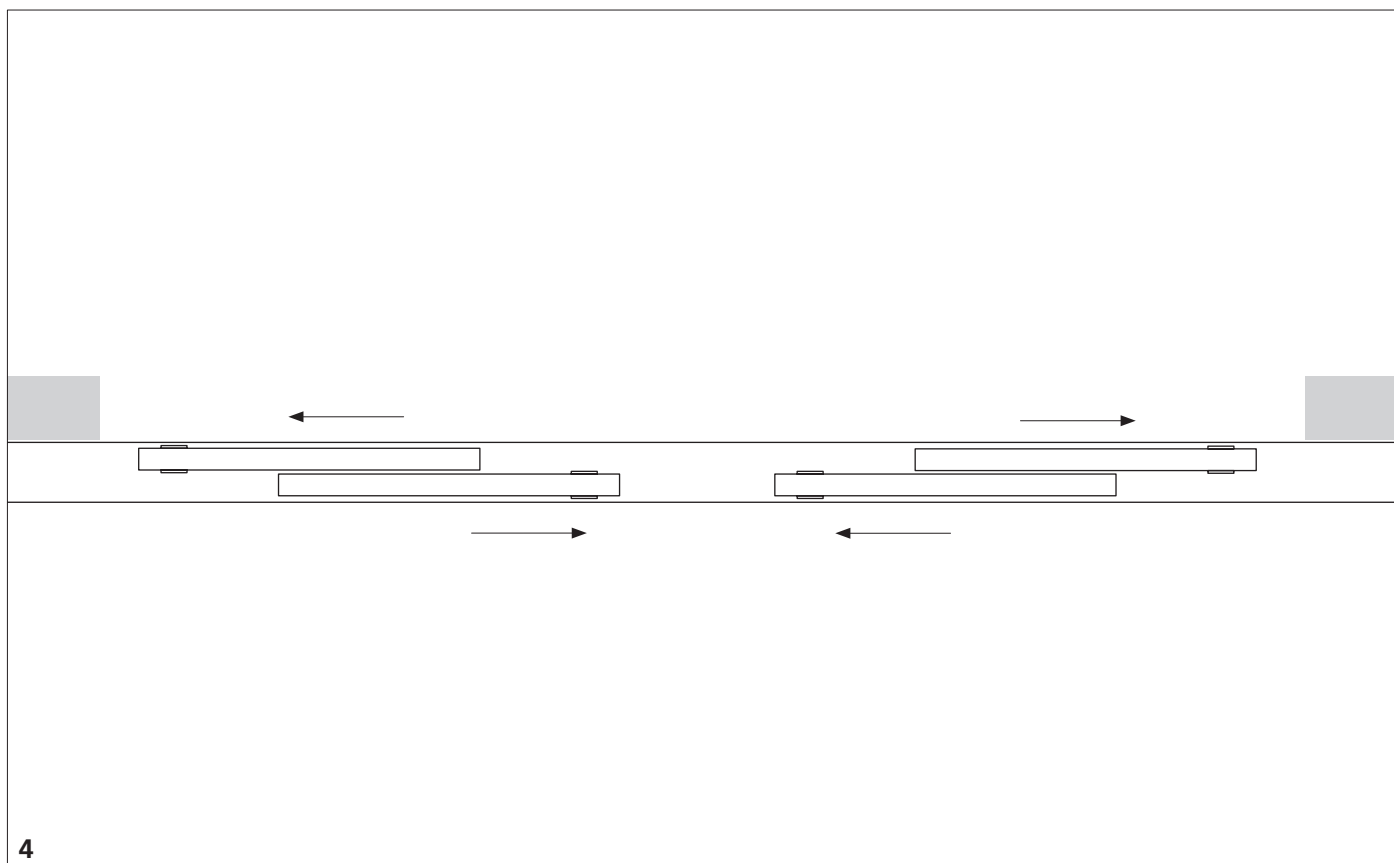

4. Portare le ante nella posizione di chiusura.
4. Place the doors in the closing position.

Installazione ante / Doors installation

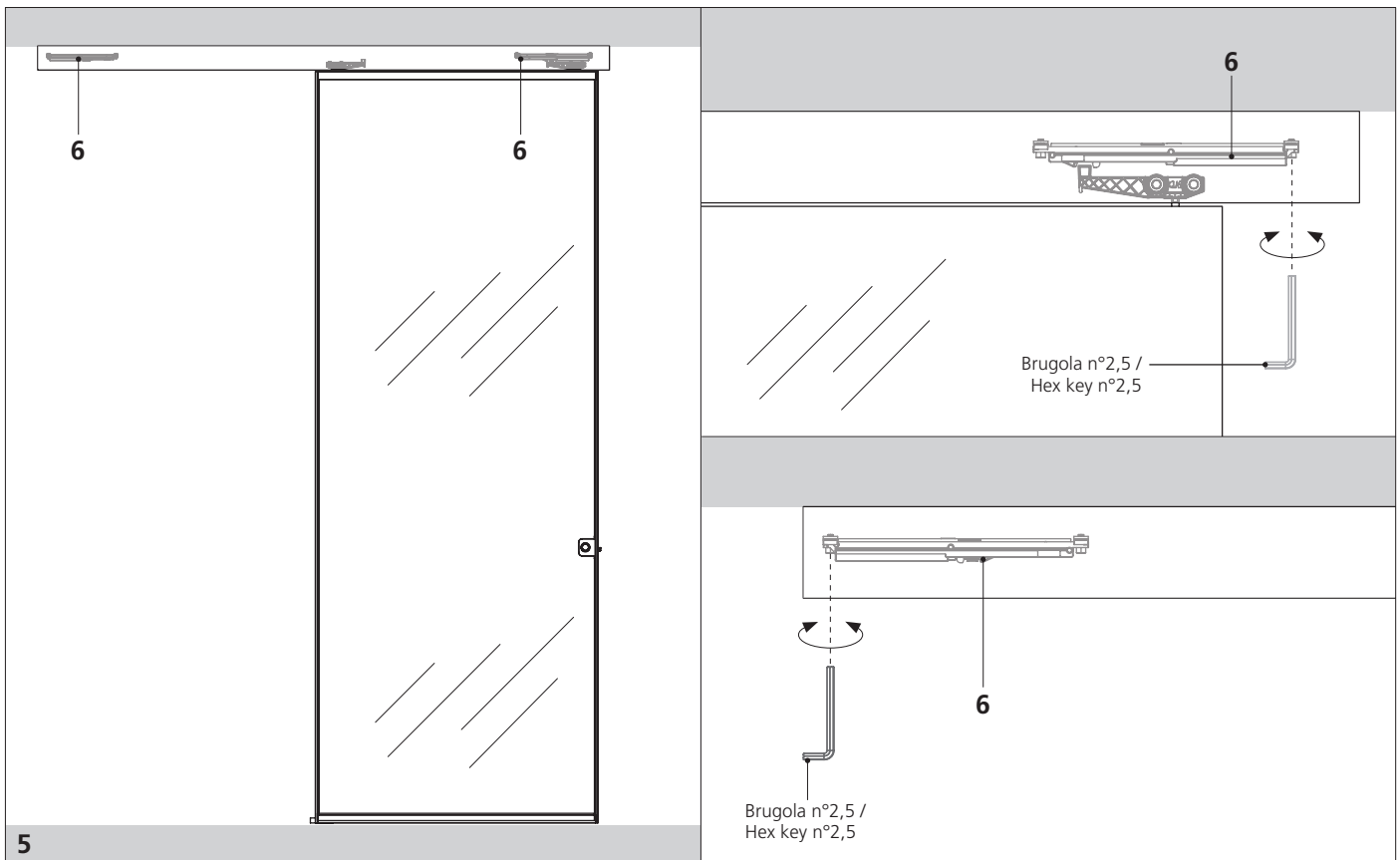

5. Posizionare i rallentatori alla giusta distanza e stringere le viti di fissaggio.
5. Place the slow motions in the correct position and tighten the fixing screws.

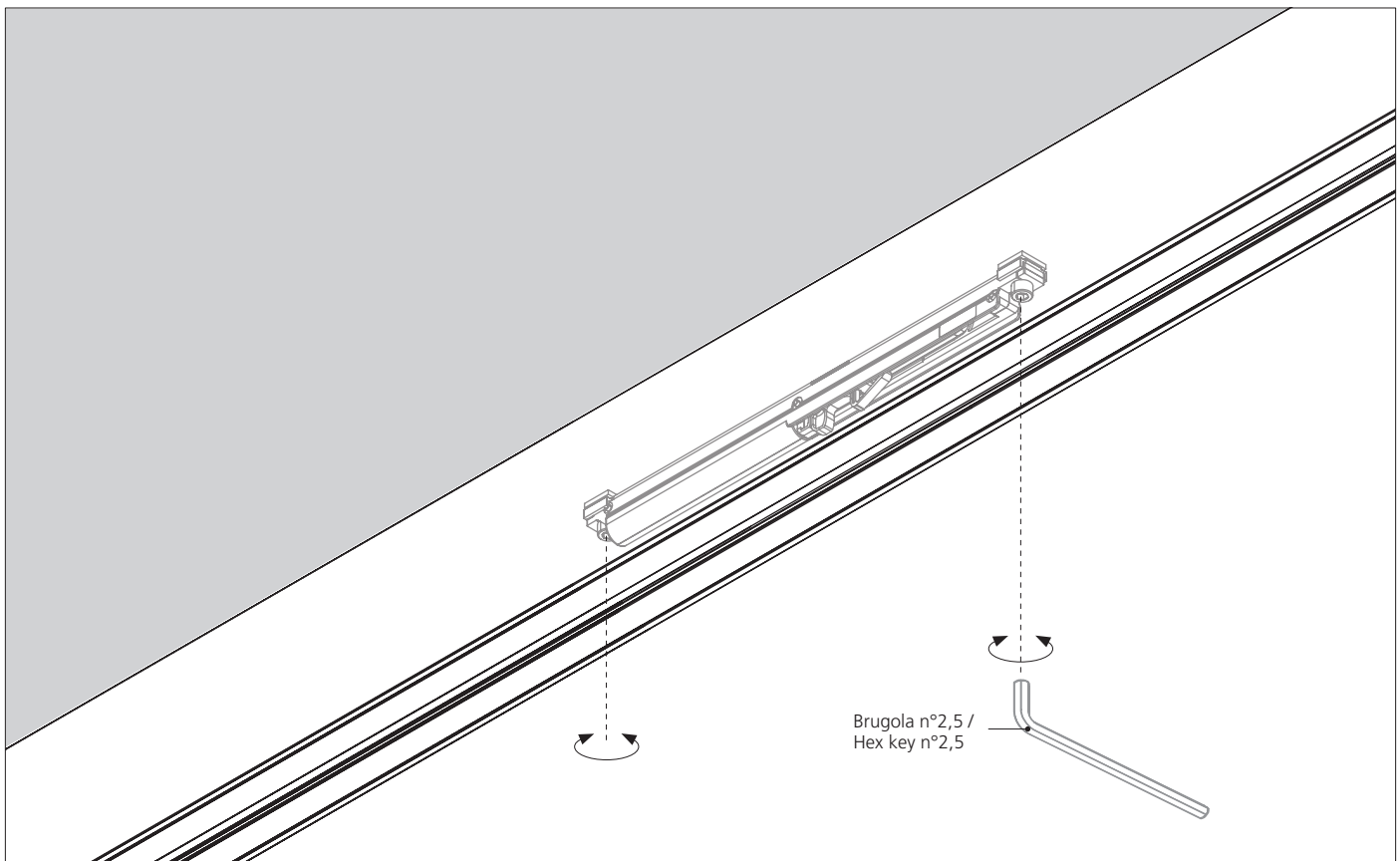

Installazione ante / Doors installation

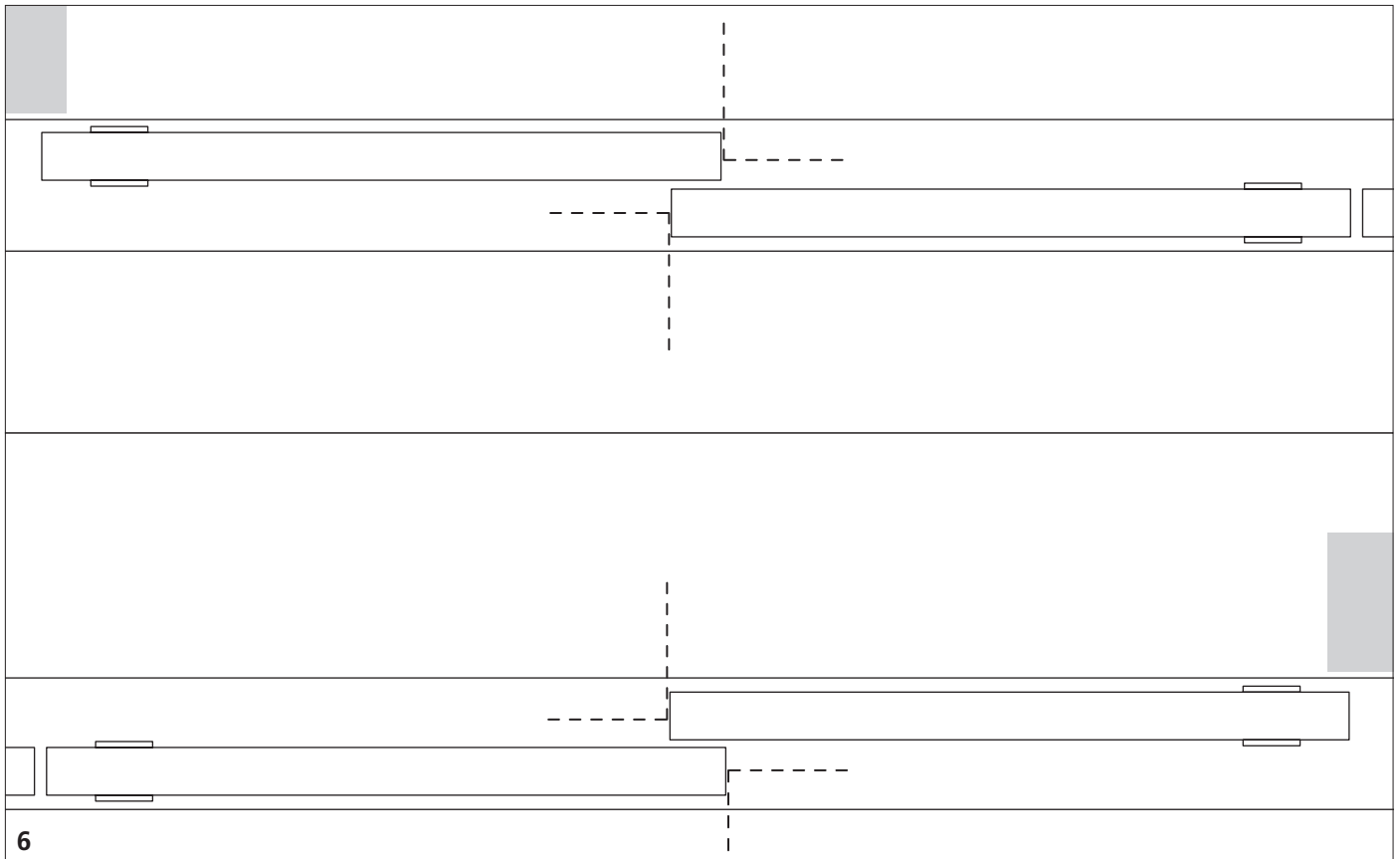

6

6. Segnare la posizione delle ante per posizionare i perni a pavimento.
6. Mark the doors position in order to place the floor pivots.

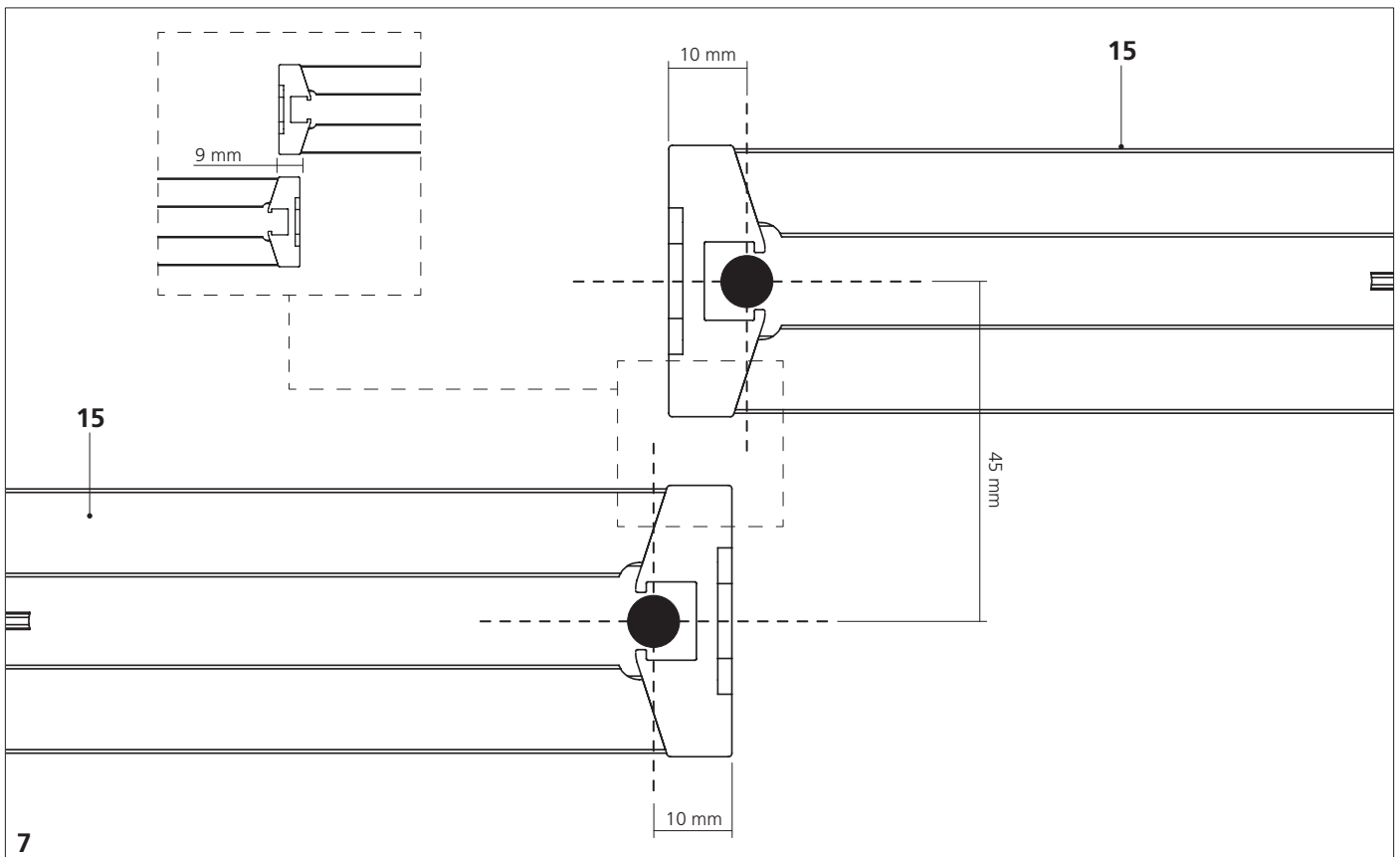

7

7. Il perno deve essere posizionato in centro all'anta e a 10 mm dal bordo posteriore. L'interasse tra i perni è 45 mm.
7. The floor pivot has to be placed in the middle of the door and at 10 mm from the rear edge. The distance between the pivots is 45 mm.

Installazione ante / Doors installation

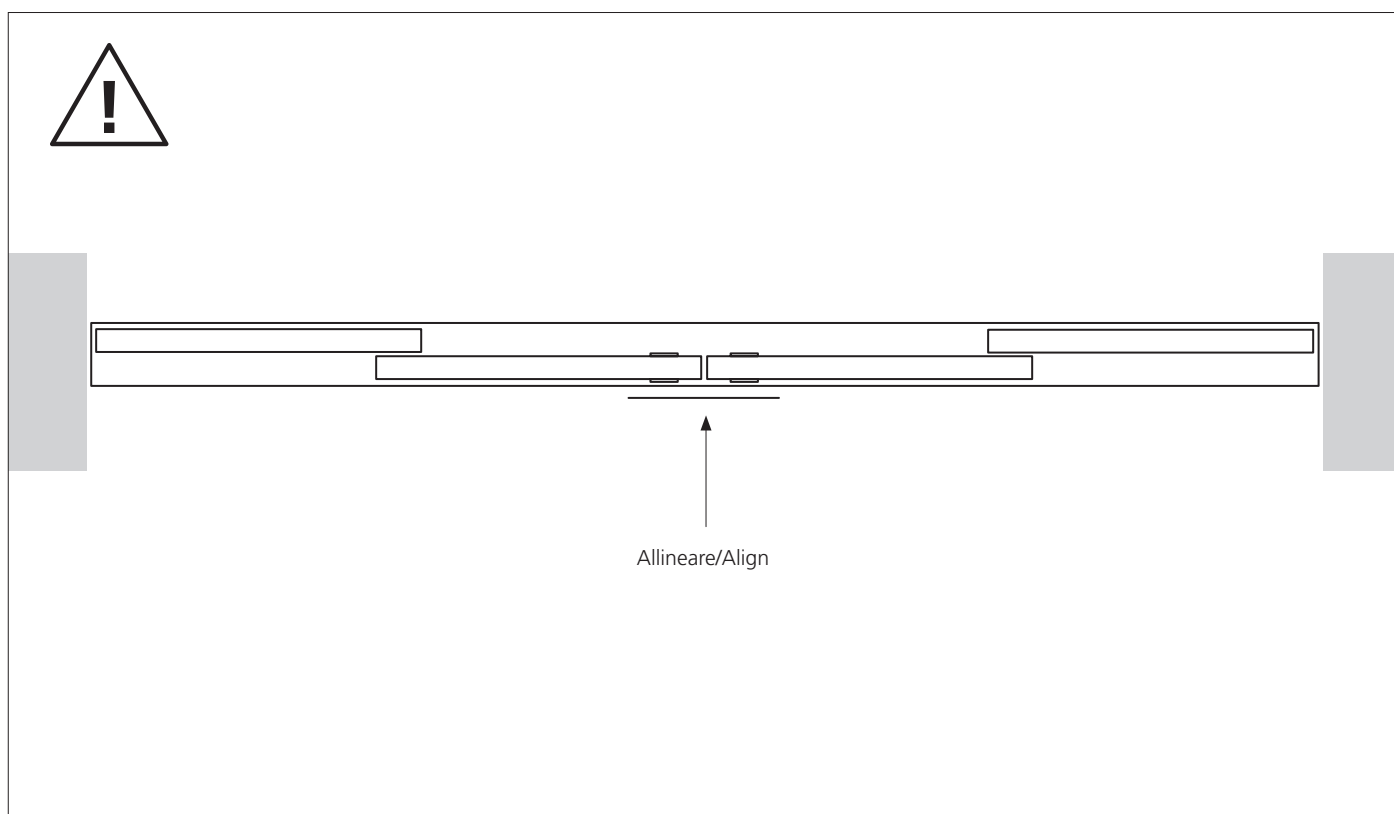

ATTENZIONE: Nel caso di due ante con chiusura complanare, prima di forare il pavimento per il fissaggio dei perni guida verificare il perfetto allineamento delle stesse.

ATTENTION: In case of two doors with coplanar closing, check the perfect alignment of them before drilling the floor for the fixing of the guiding pivots.

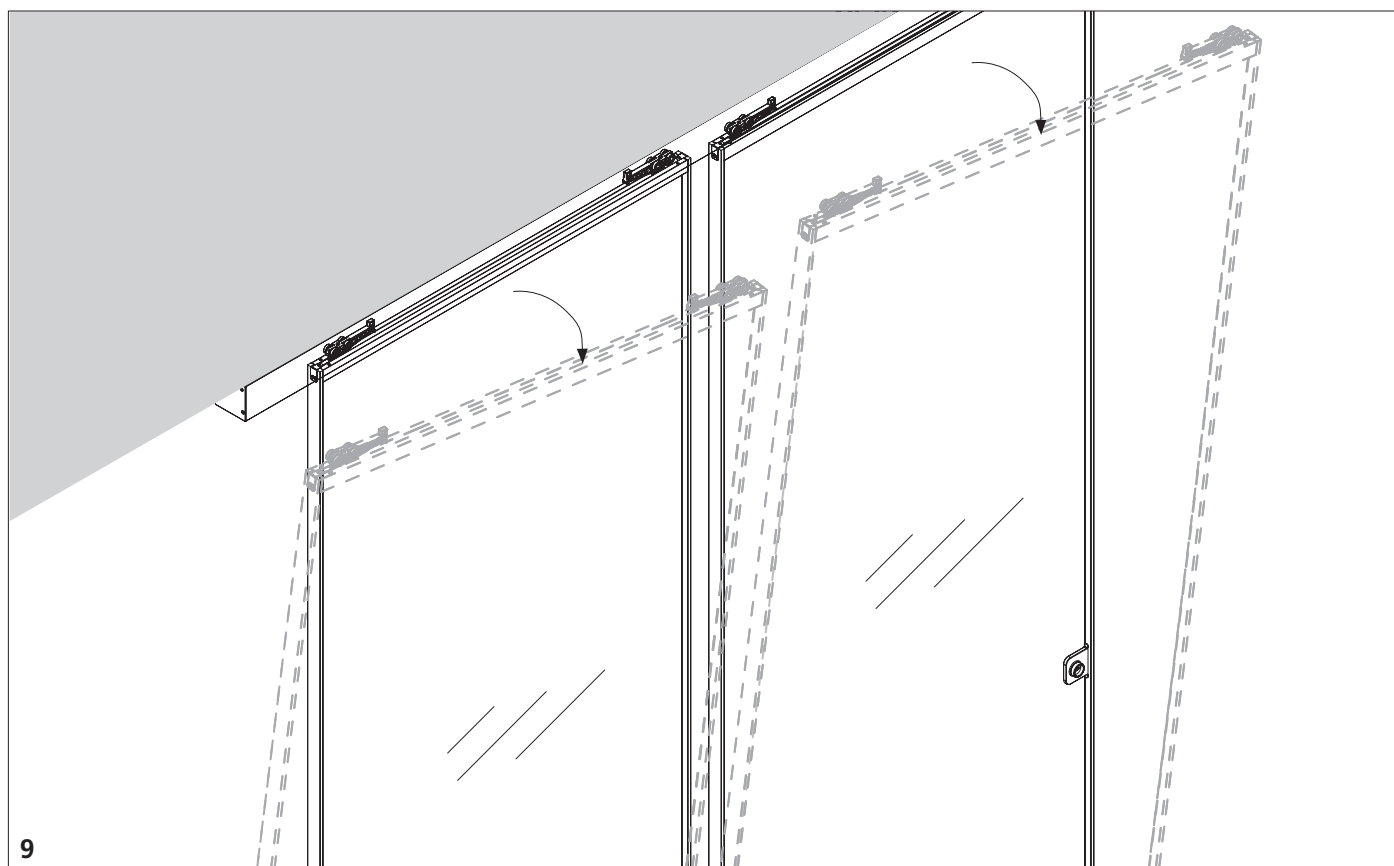

9. Svitare i carrelli e togliere tutte le ante.

9. Unscrew the carriers and remove all the doors.

Installazione ante / Doors installation

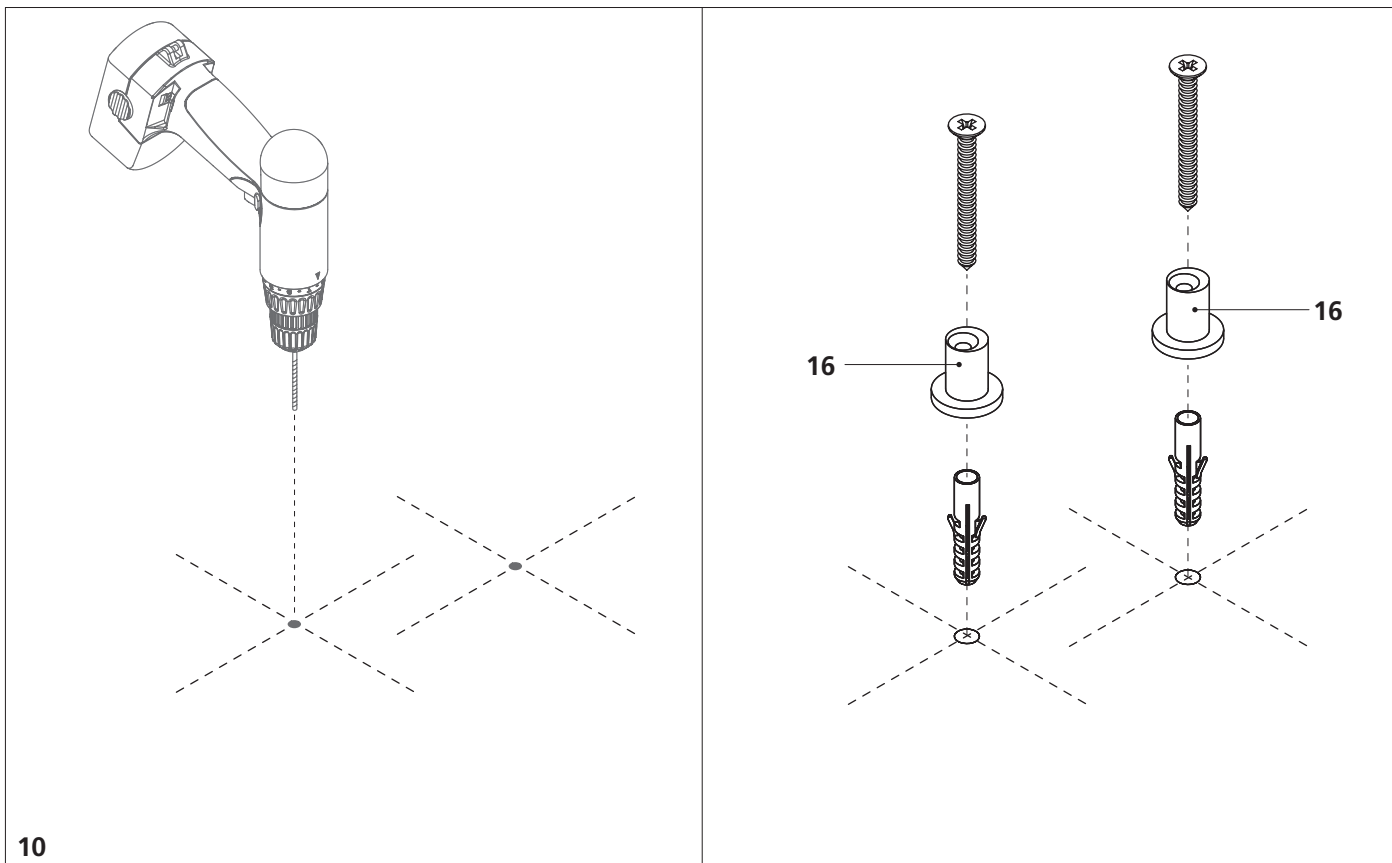

10. Forare e fissare il perno a pavimento.
10. Drill and fix the floor pivot to the floor.

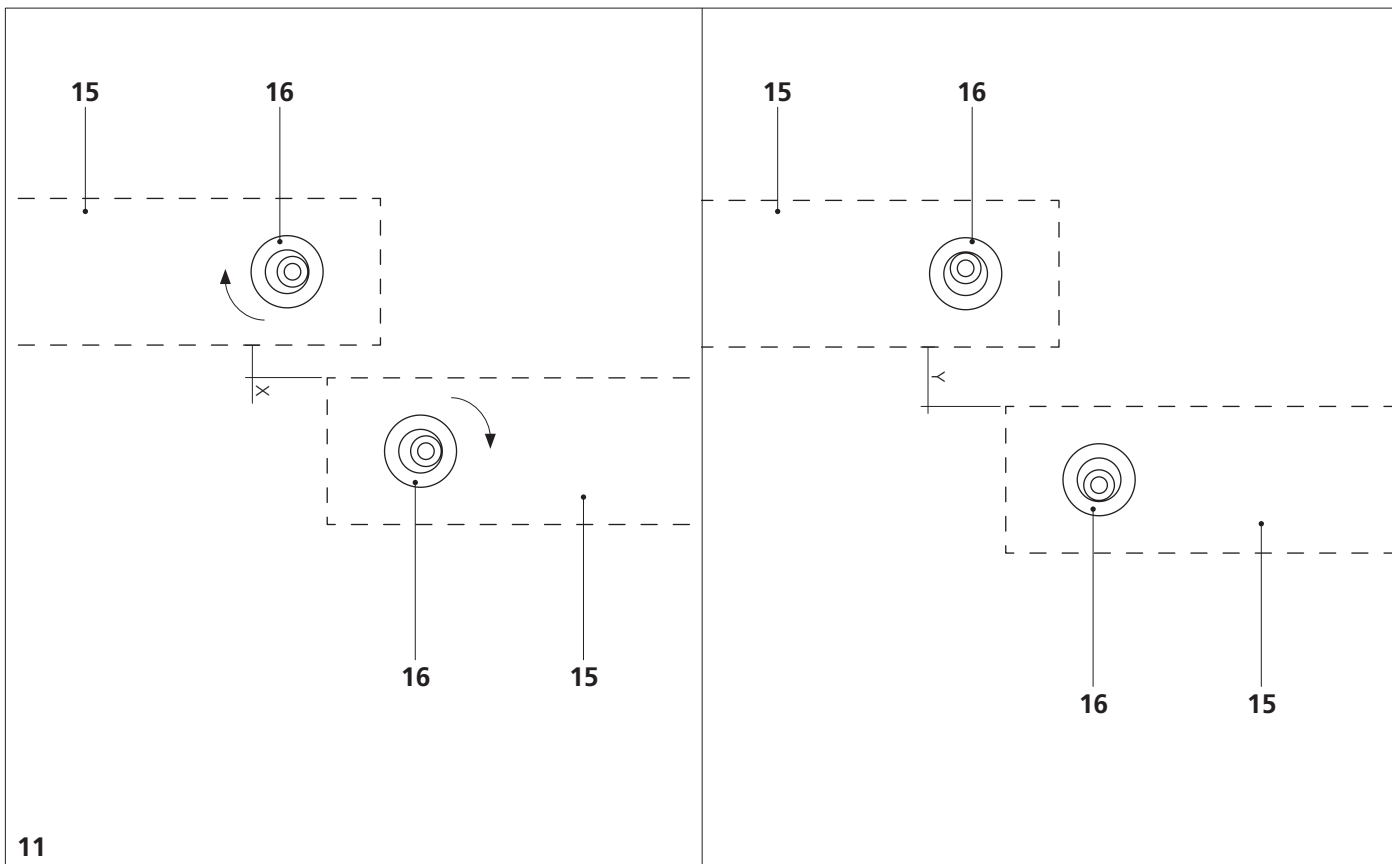

11. Se necessario regolare i perni a pavimento tramite il foro eccentrico.
11. If necessary, adjust the floor pivots through the eccentric hole.

Installazione ante / Doors installation

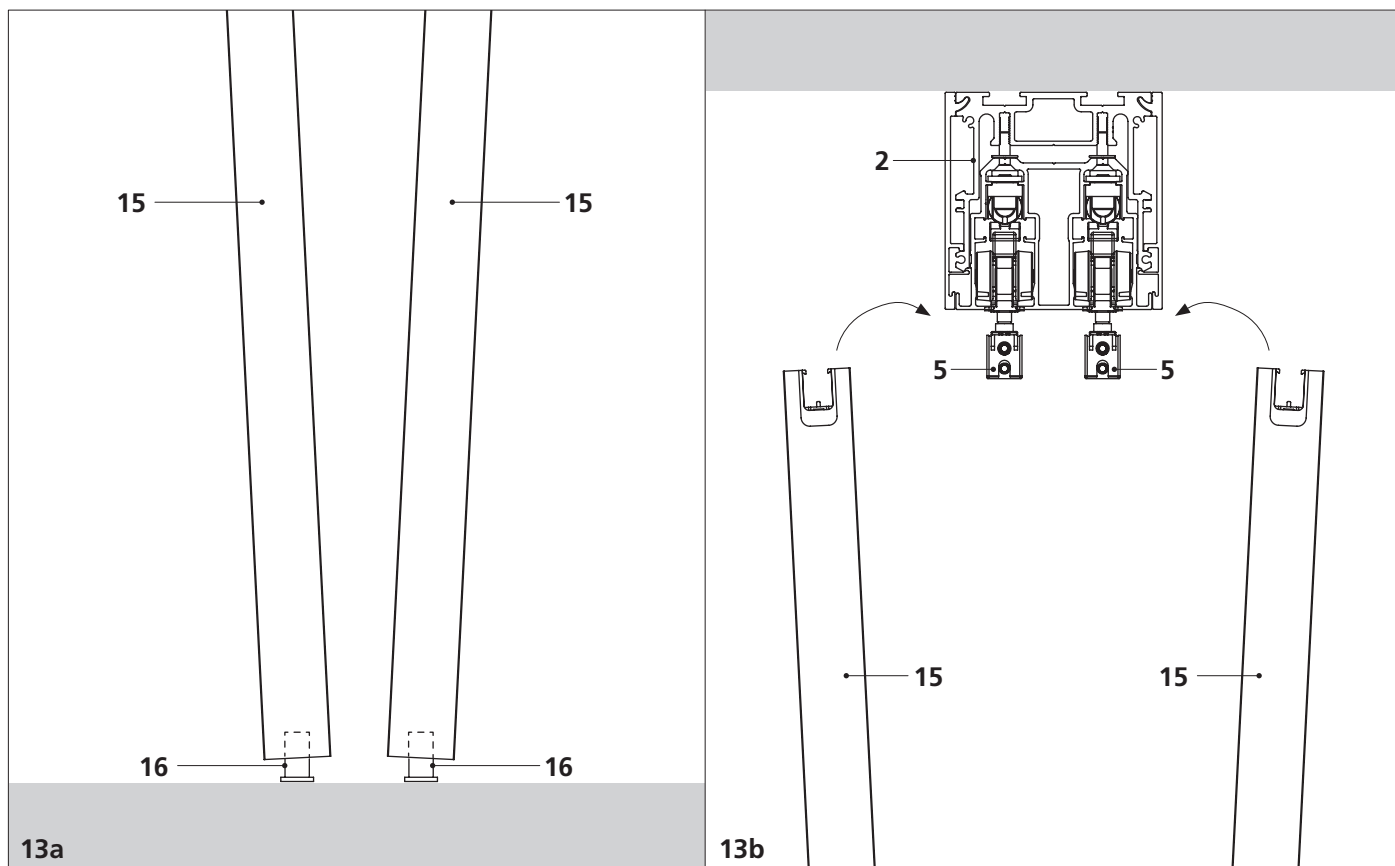
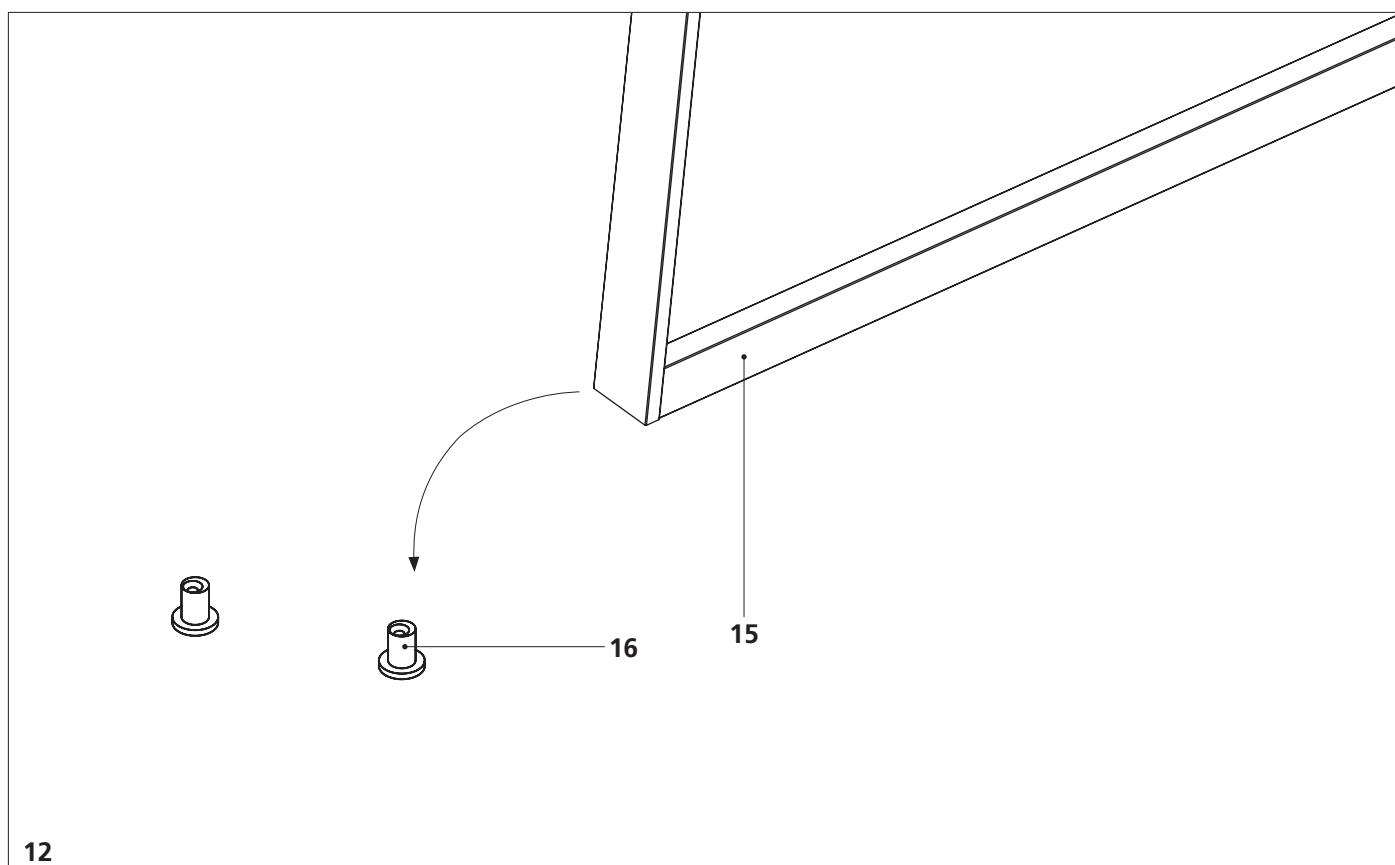

13. Calzare l'anta sul perno, sollevarla e avvicinarla ai carrelli inseriti nel binario.
 13. Insert the door on the pivot, lift it and bring it close to the carriages inserted in the beam.

Installazione ante / Doors installation

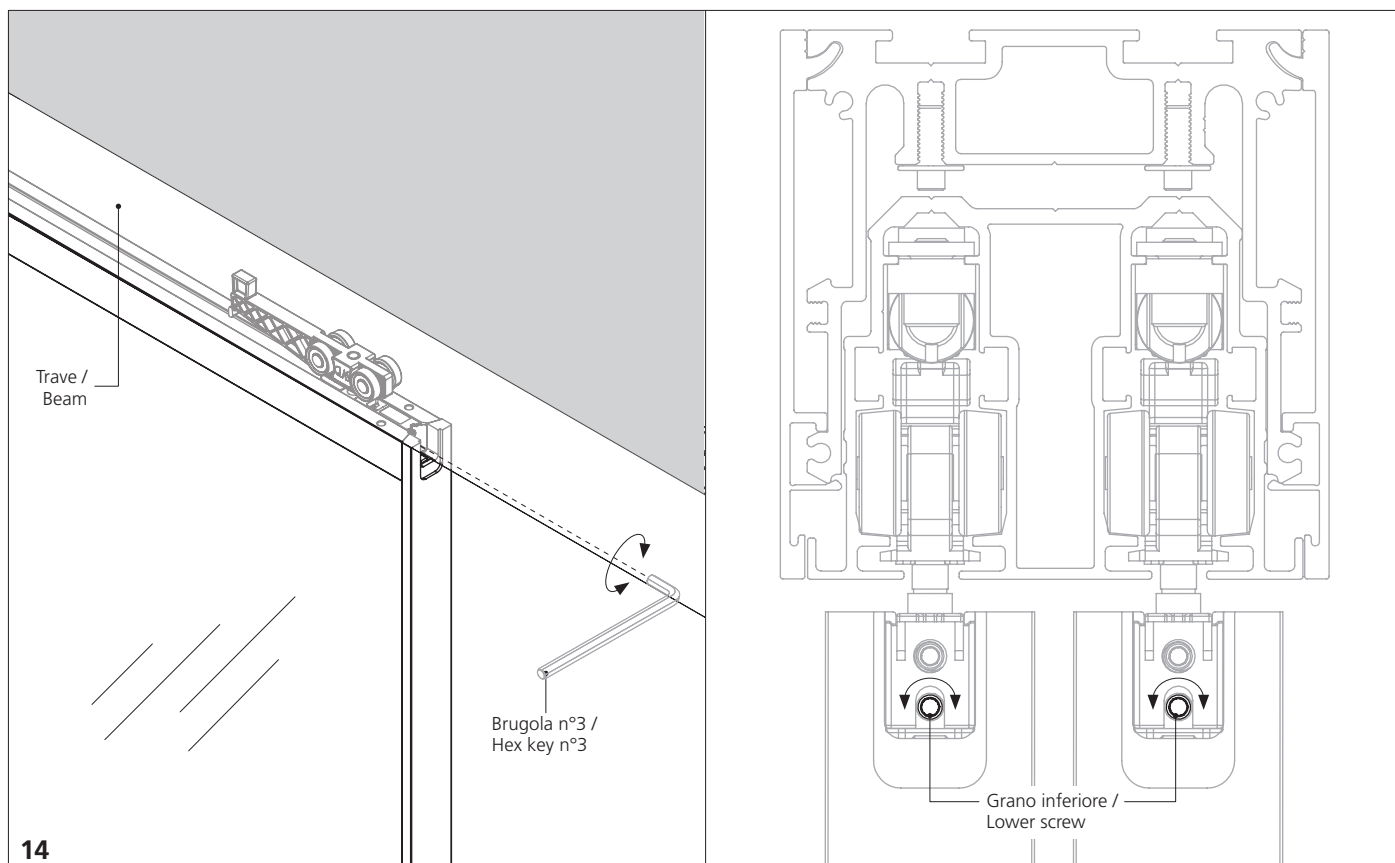

14. Avvitare il grano inferiore per bloccare il carrello.
14. Screw the lower grain to lock the carriage.

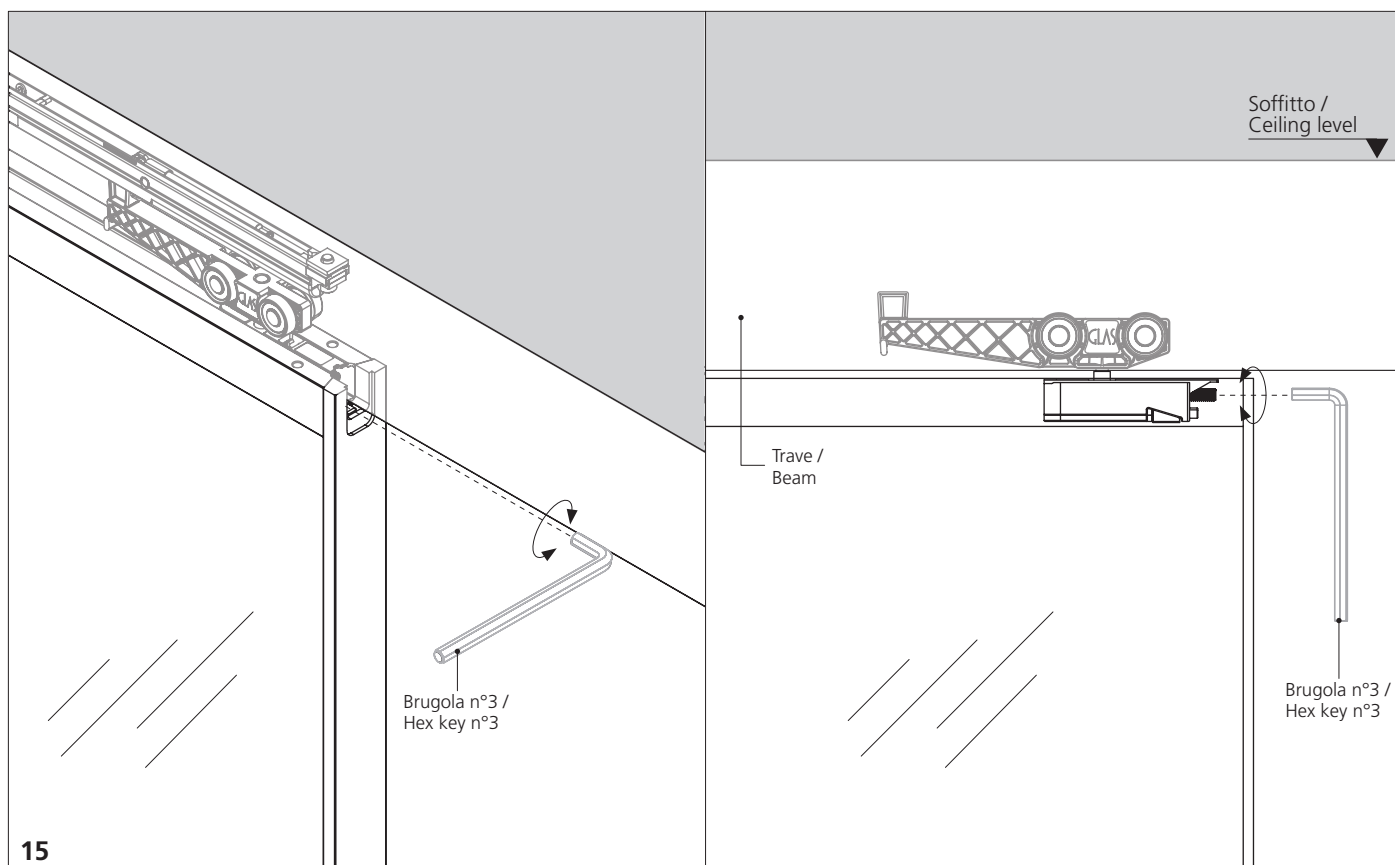

15. Per una regolazione millimetrica dell'anta, agire sulla vite superiore presente nel carrello di scorrimento.
15. To adjust the door millimetrically, act on the upper screw placed in the sliding carriage.

Installazione ante / Doors installation

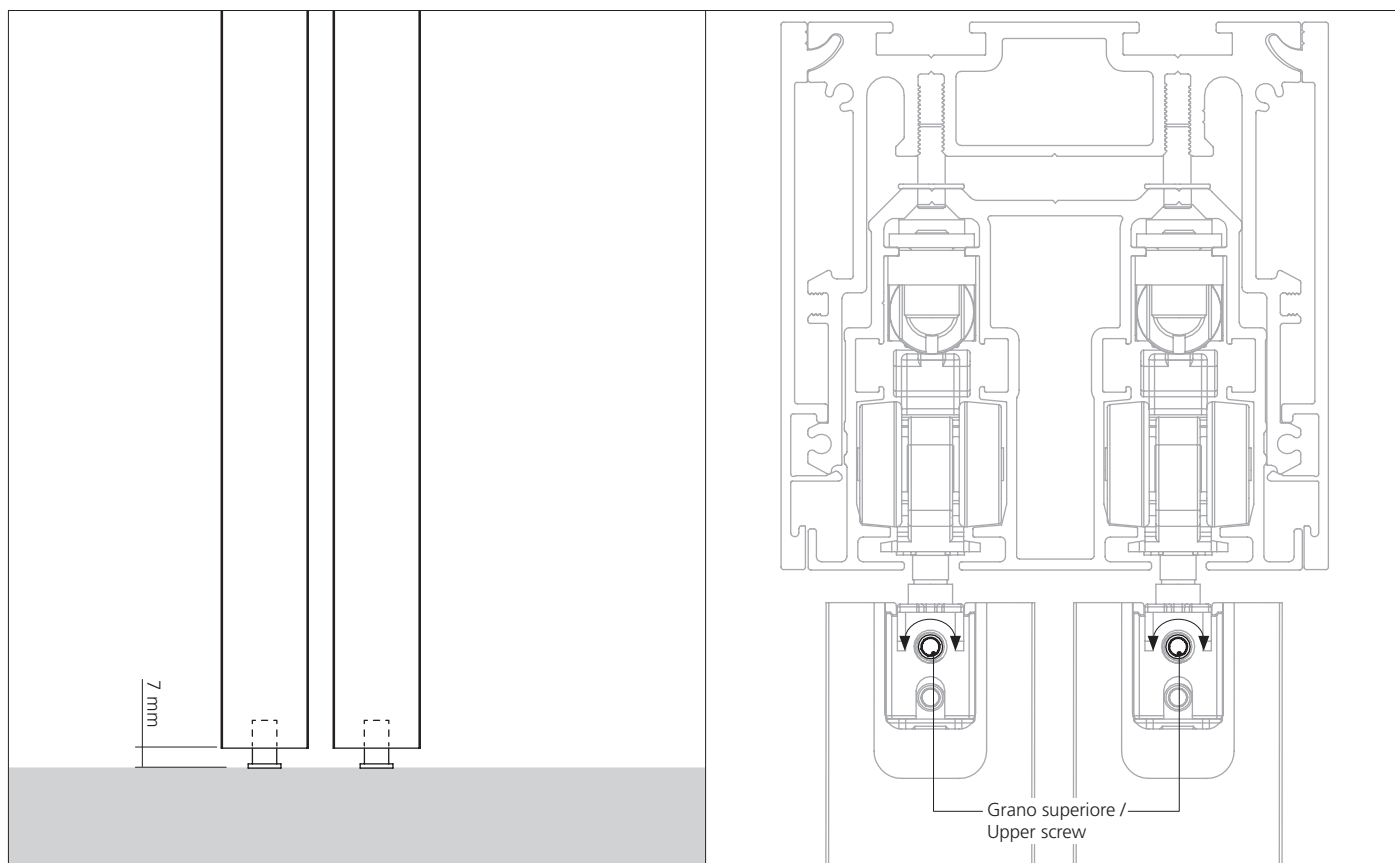

Misura ideale per lo scorrimento dell'anta.
Ideal measure for the door sliding.

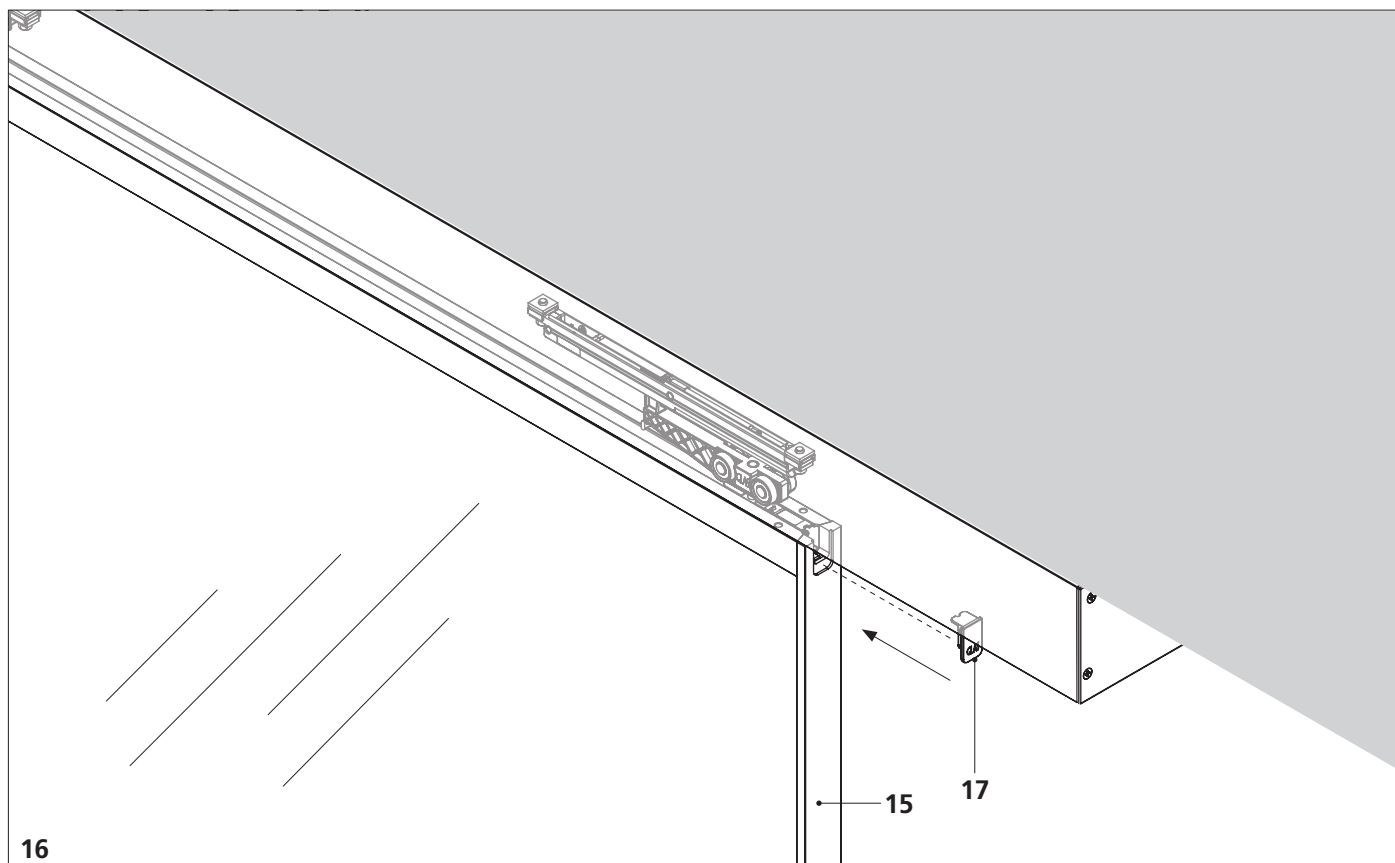

16. Posizionare a pressione il tappo copri carrello sulle ante.
16. Position the carriage cover cap on the doors by pressing.



SHERAZADE

**Sistema scorrevole | Anta a trascinamento | Montaggio
Sliding system | Dragging door | Installation**

Installazione anta a trascinamento / Dragging door installation

Esploso componenti / Components exploded diagram	pag.	1.102
Installazione perno a trascinamento / Dragging pivot installation	pag.	1.103
Installazione anta / Door installation	pag.	1.104
Installazione perno a pavimento / Floor pivot installation	pag.	1.106
Regolazione anta / Door adjustment	pag.	1.109
Posizionamento tappo con logo / Closure cap with logo positioning	pag.	1.110

ATTENZIONE: Per evitare rumori e vibrazioni durante lo scorrimento delle ante, le ruote dei carrelli e l'interno del binario devono essere perfettamente puliti.

AVERTISSEMENT : Pour éviter le bruit et les vibrations pendant le glissement des portes, les roues des chariots et l'intérieur du rail doivent être parfaitement propres.

ACHTUNG: um Geräusche und Vibrationen während des Gleitens der Türen zu vermeiden, sollen die Räder der Wagen und die Innerseite der Schiene perfekt sauber sein.

ATTENTION: To avoid noises and vibrations during the door's sliding, the wheels of the carriages and the inside of the rail must be perfectly clean.

ATENCIÓN: Para evitar ruidos y vibraciones durante el deslizamiento de las puertas, las ruedas de los carrillos y el interior de la guía tienen que ser perfectamente limpios.

Installazione anta a trascinamento / Dragging door installation

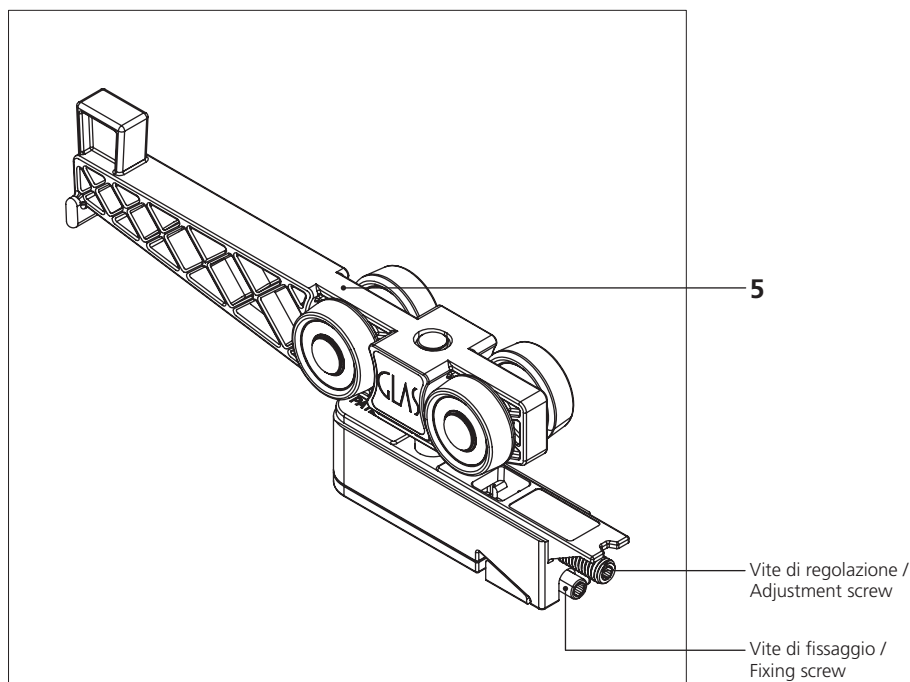

- 1b. Carter di finitura / Finishing case
- 2. Trave / Beam
- 3. Binario / Rail
- 4. Staffa / Bracket
- 5. Carrello / Carriage
- 6. Rallentatore / Slow motion device
- 15. Anta mobile / Sliding door
- 16. Perno a pavimento / Floor pivot
- 17. Tappo con logo / Closure cap with logo
- 21. Anta trascinata / Door without dragging pivot
- 22. Perno per trascinamento / Dragging pivot
- 23. Anta trascinante / Door with dragging pivot

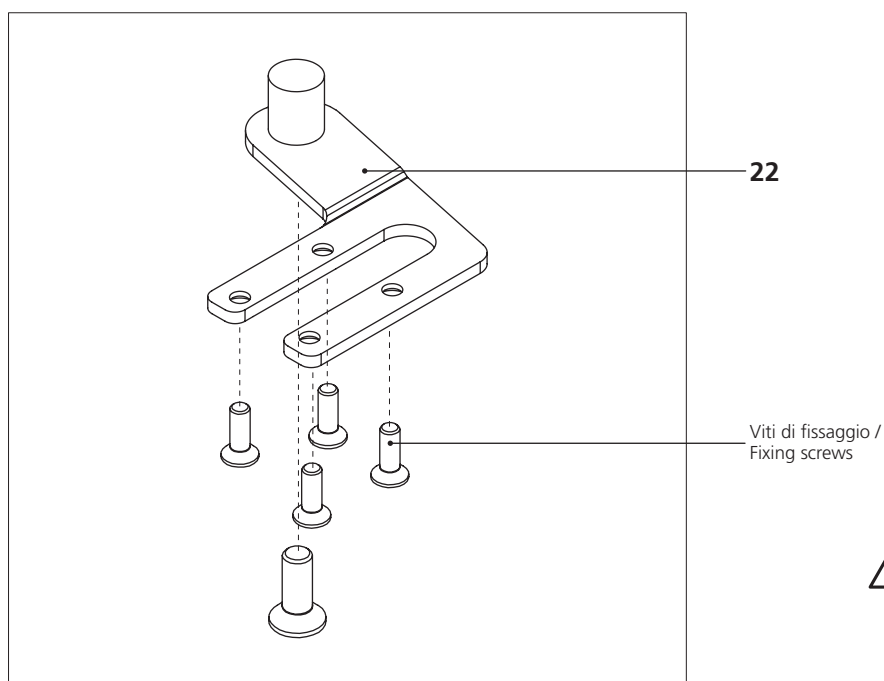

ATTENZIONE: Prima di proseguire con il montaggio, leggere attentamente tutto il fascicolo delle istruzioni. /
WARNING: Before proceeding with the installation, read carefully all the installation manual.

Simbologia e strumenti di montaggio / Symbology and assembly tools



Fare attenzione/
Pay attention



Allineare/
Align

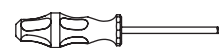

Cacciavite a croce/
Crosshead screwdriver



Avvicinare - togliere/
Bring closer - Remove



Avvitare-regolare/
Screw-adjust



Chiave a brugola/
Hex key



In squadra/
At right angle



Inserisci/
Insert



Quota/
Level

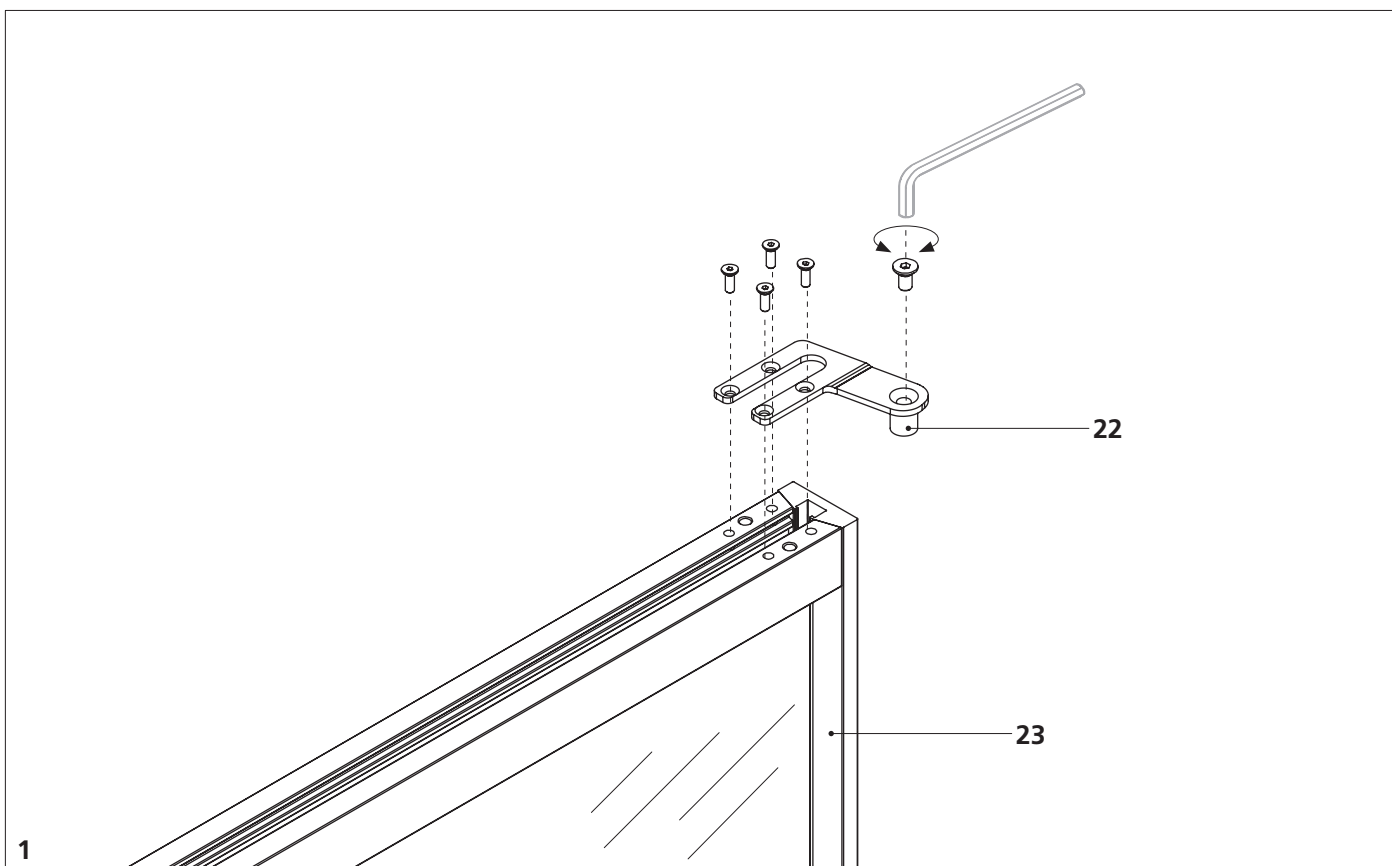

1. Capovolgere l'anta e fissare il perno a trascinamento.
1. Turn upside down the door and fix the dragging pivot.

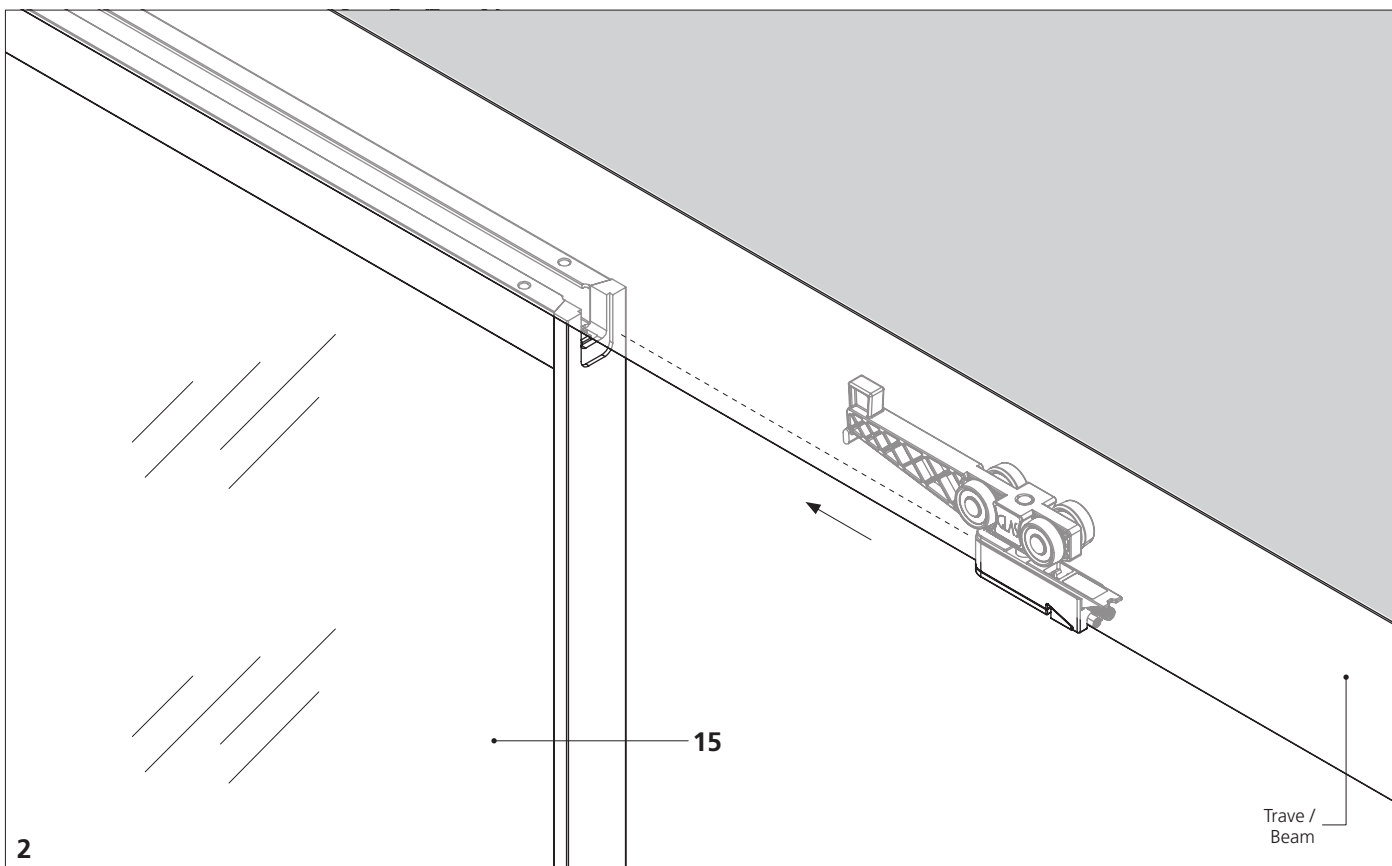

2. Agganciare l'anta ai carrelli.
2. Hook the door to the sliding carriages.

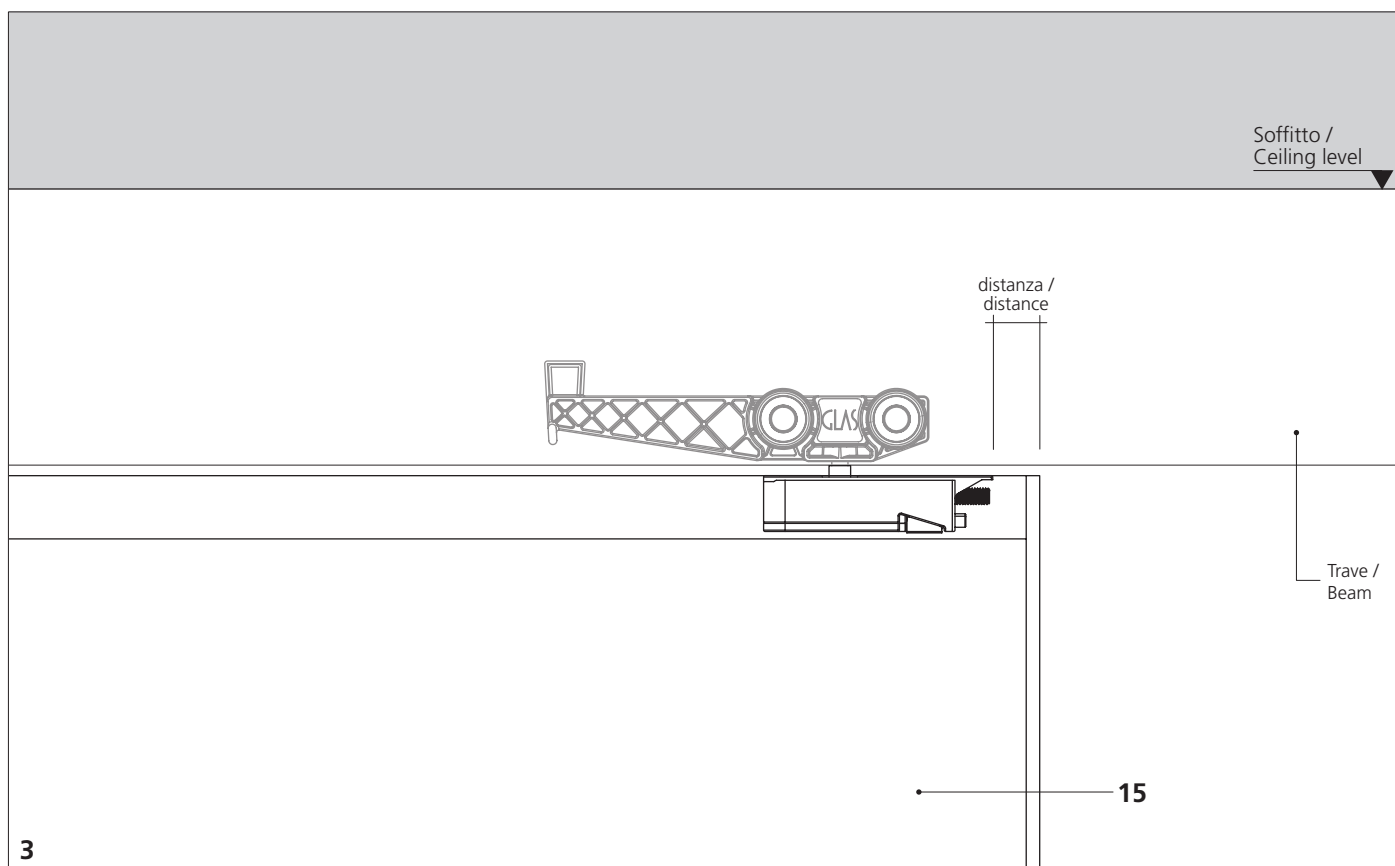

3. La lavorazione presente sul traverso dell'anta identifica la posizione del carrello rispetto al bordo dell'anta stessa.
3. Machining on the door's crosspiece identifies the position of the carriage in relation to the door's edge.

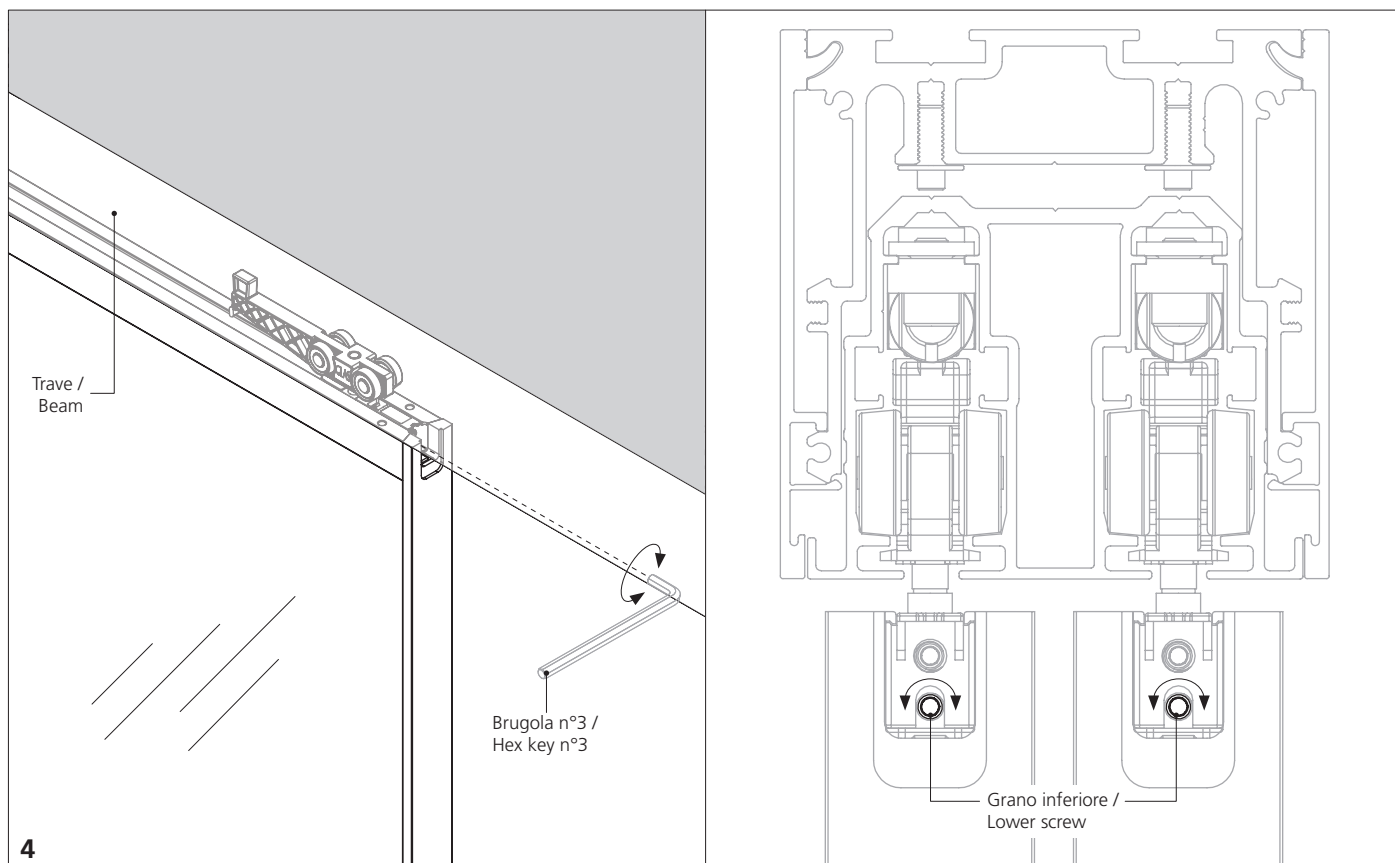

4. Avvitare il grano inferiore per bloccare il carrello. Ripetere i passaggi da n°1 a 3 per tutte le ante.
4. Screw the lower grain to block the carriage. Repeat the steps from n° 1 to 3 for all doors.

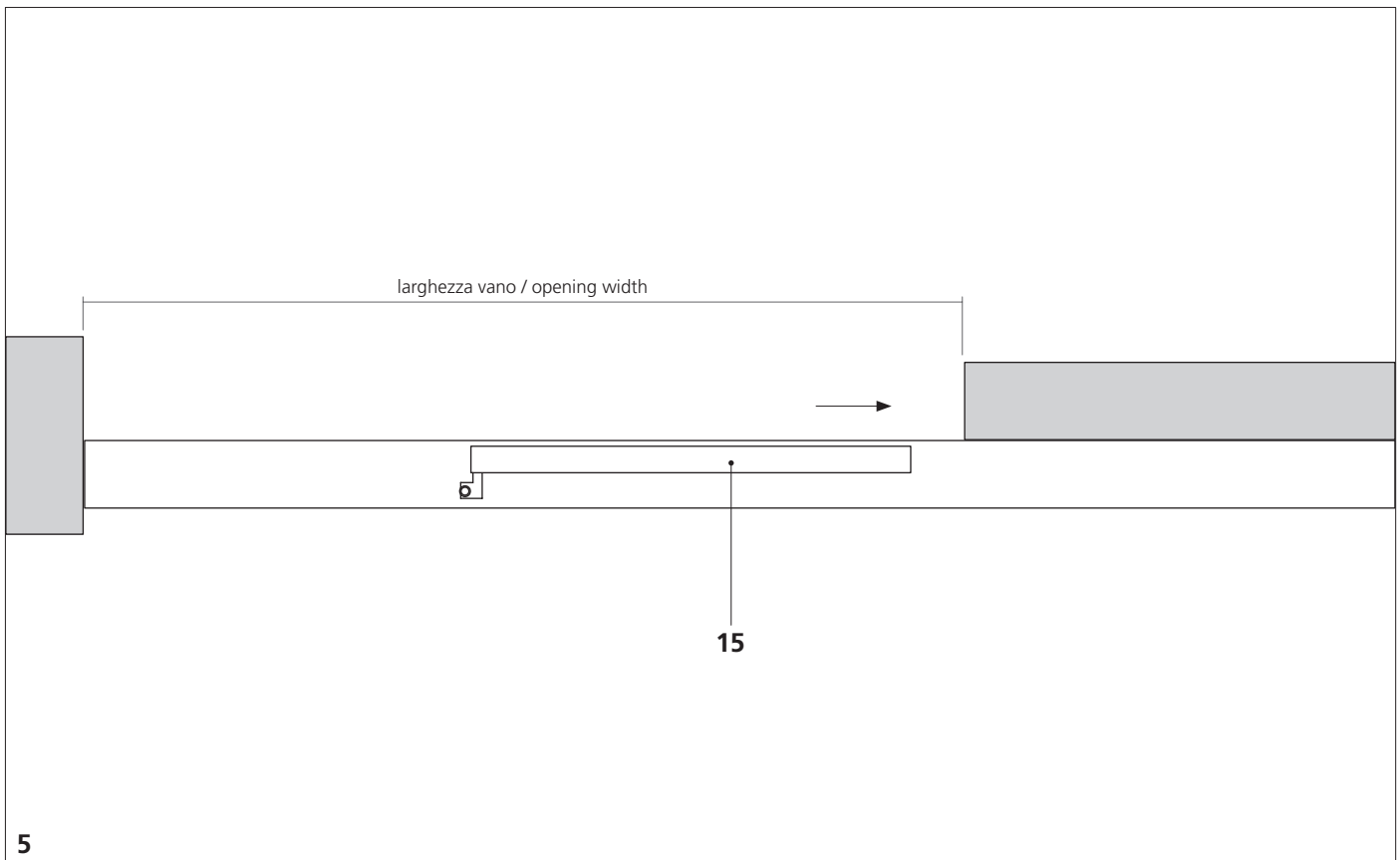

5. Posizionare la prima anta nella posizione di chiusura.
5. Place the first door in the closure position.

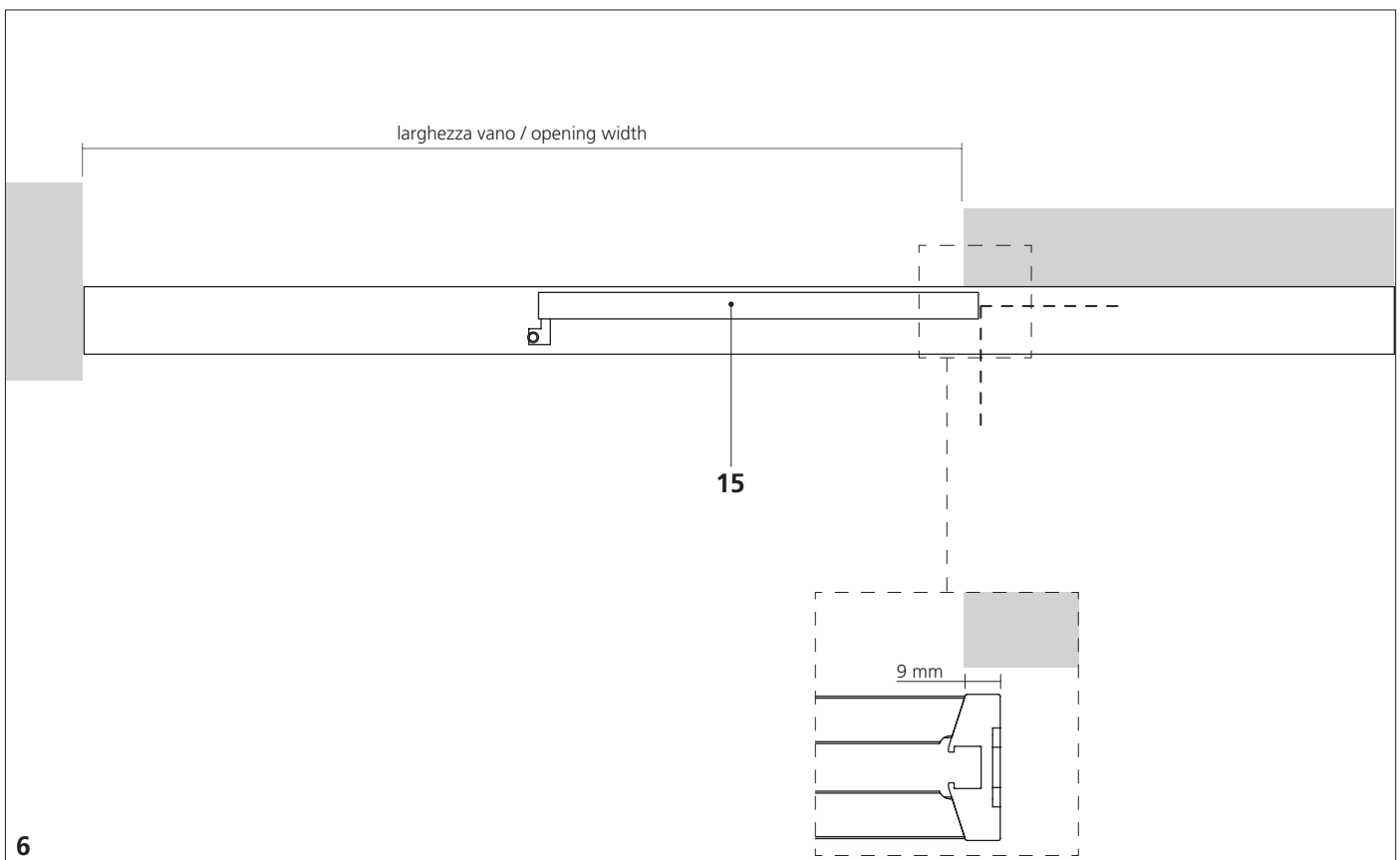

6. Segnare la posizione dell'anta per posizionare il perno a pavimento.
6. Mark the door position in order to place the floor pivot.

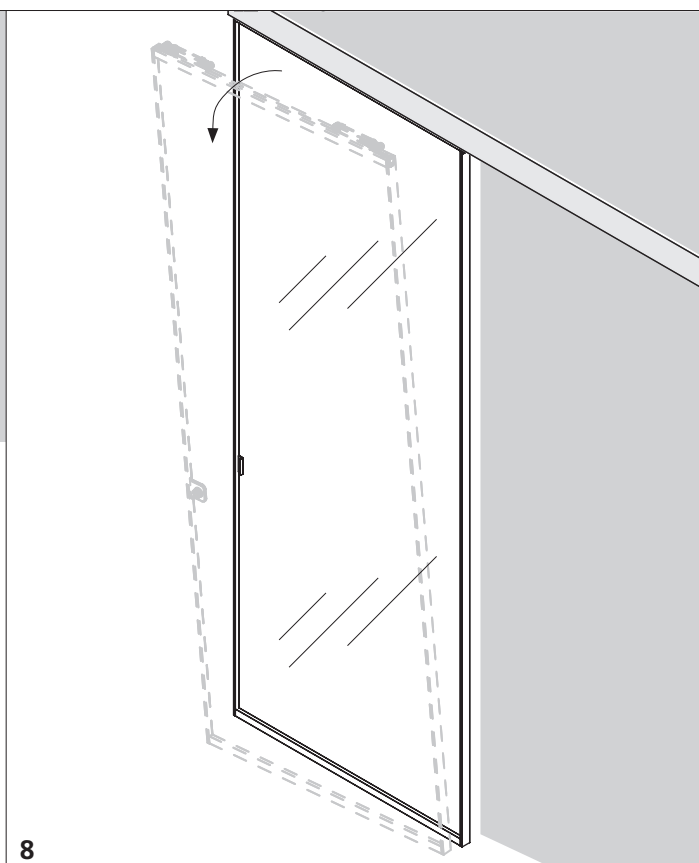
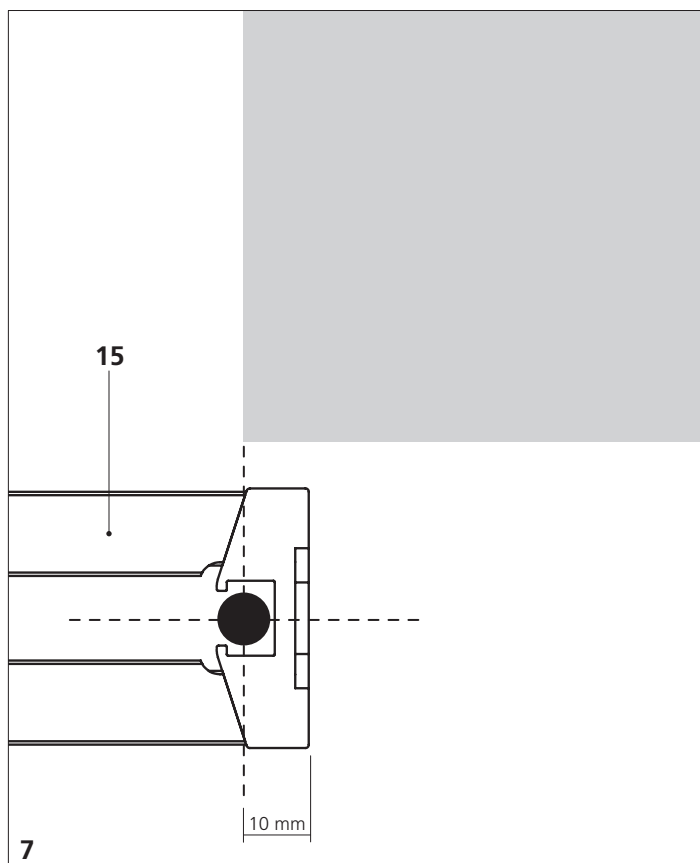

7. Il perno deve essere posizionato in centro all'anta e a 10 mm dal bordo posteriore. / 8. Svitare i carrelli e togliere l'anta.
7. The floor pivot has to be placed in the middle of the door and at 10mm from the rear edge. / 8. Unscrew the carriages and remove the door.

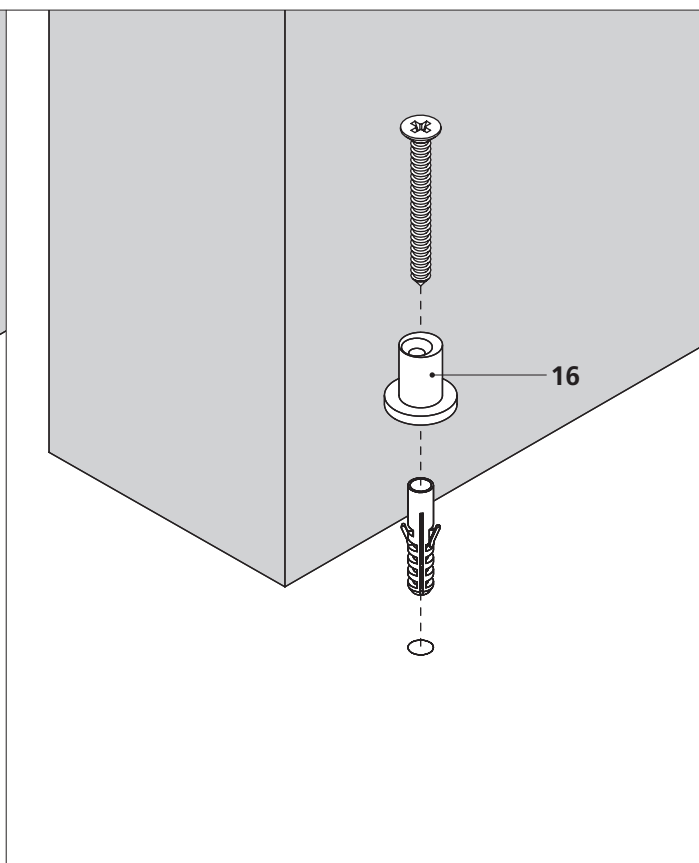
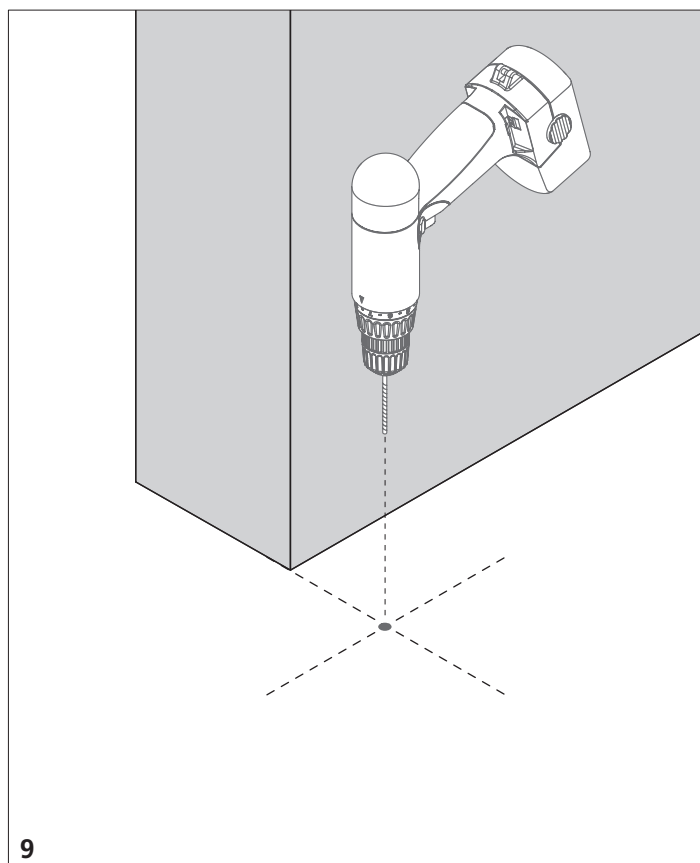

9. Forare e fissare il perno a pavimento.
9. Drill and fix the floor pivot to the floor.

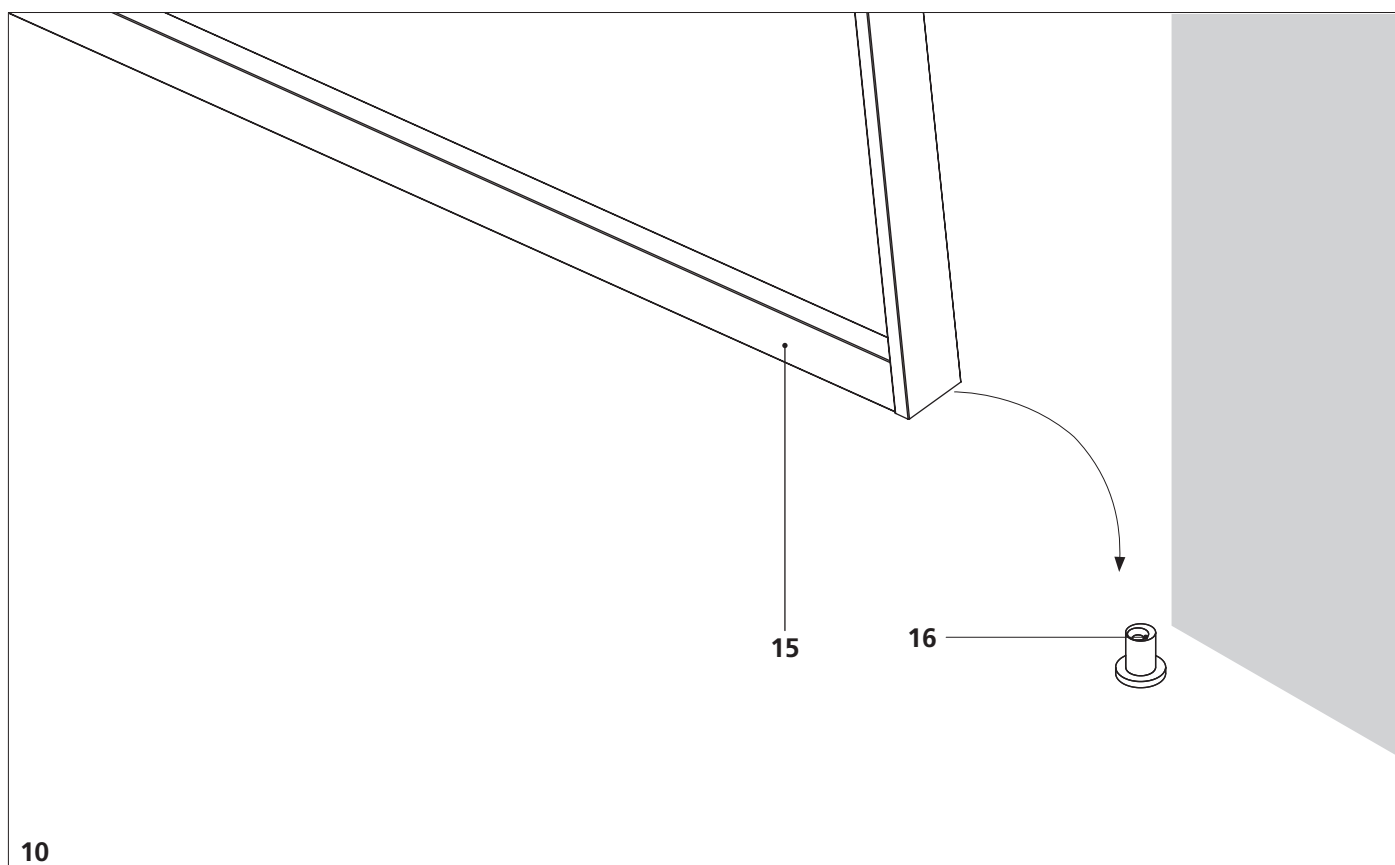

10. Infilare l'anta sopra al perno a pavimento.
10. Insert the door on the floor pivot.

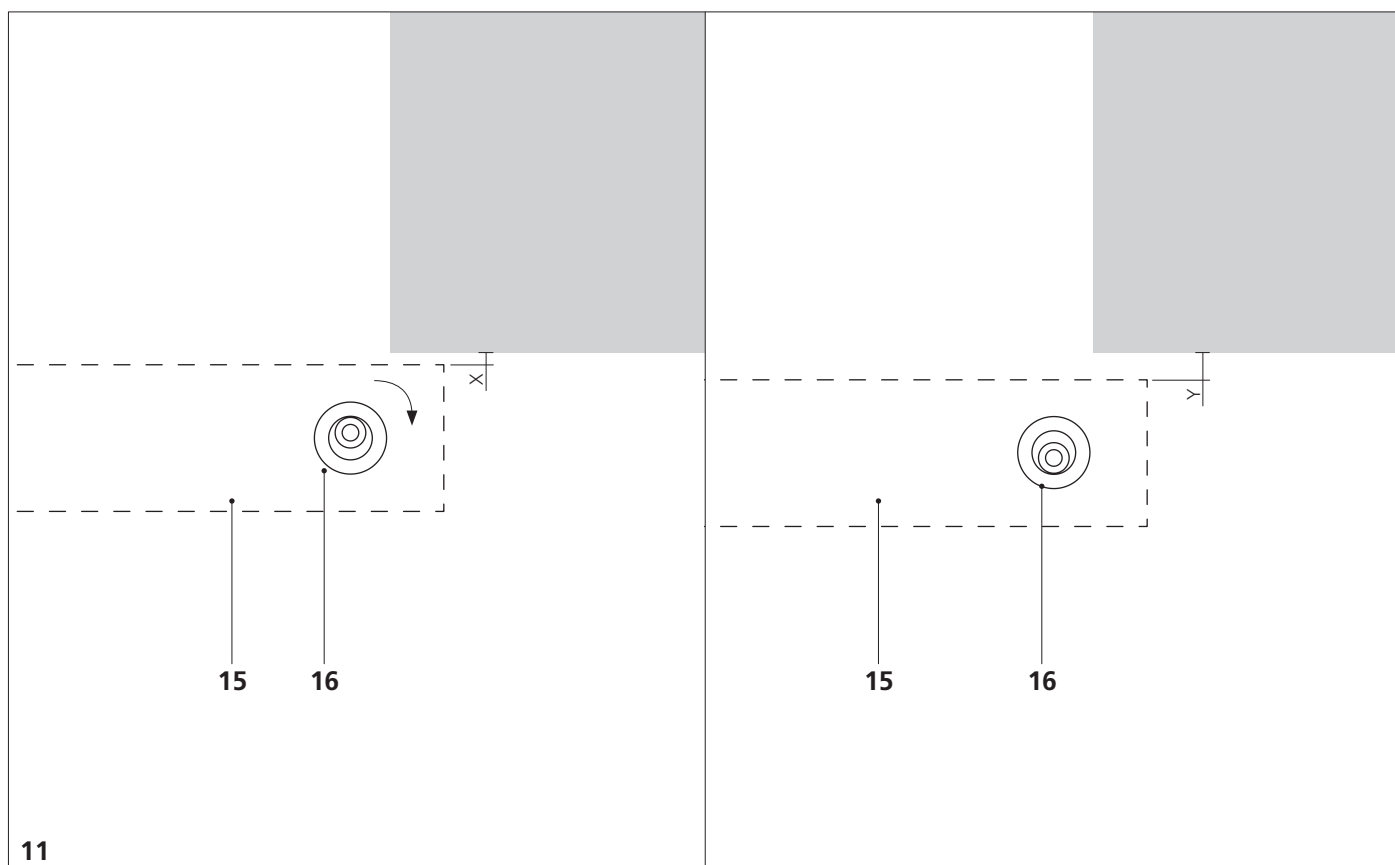

11. Se necessario regolare il perno a pavimento tramite il foro eccentrico.
11. If necessary, adjust the floor pin through the eccentric hole

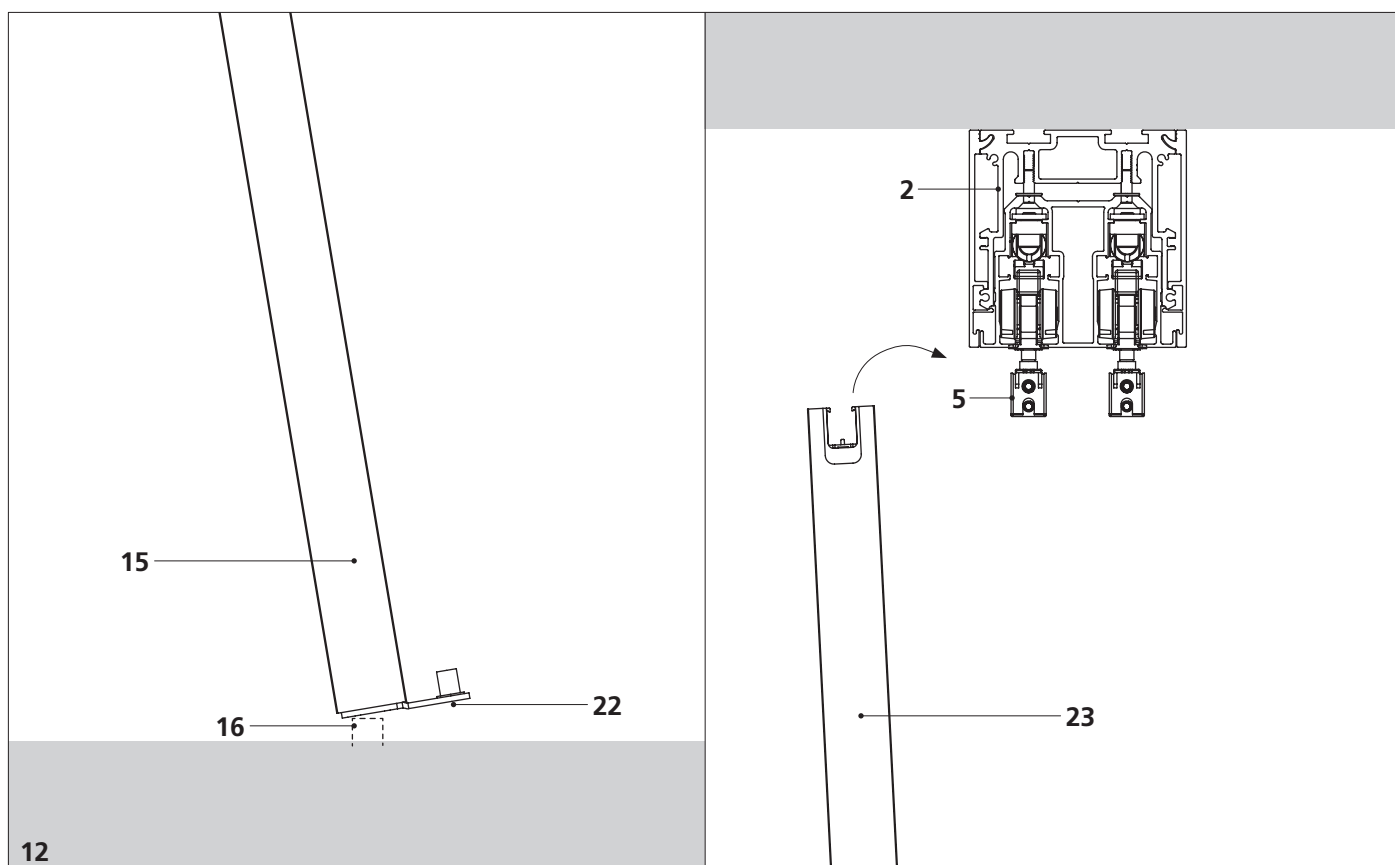

12. Calzare la prima anta sul perno a pavimento, sollevarla e avvicinarla ai carrelli inseriti nel binario.
 12. Insert the first door on the floor pivot, lift it and bring it close to the carriages inserted in the beam.

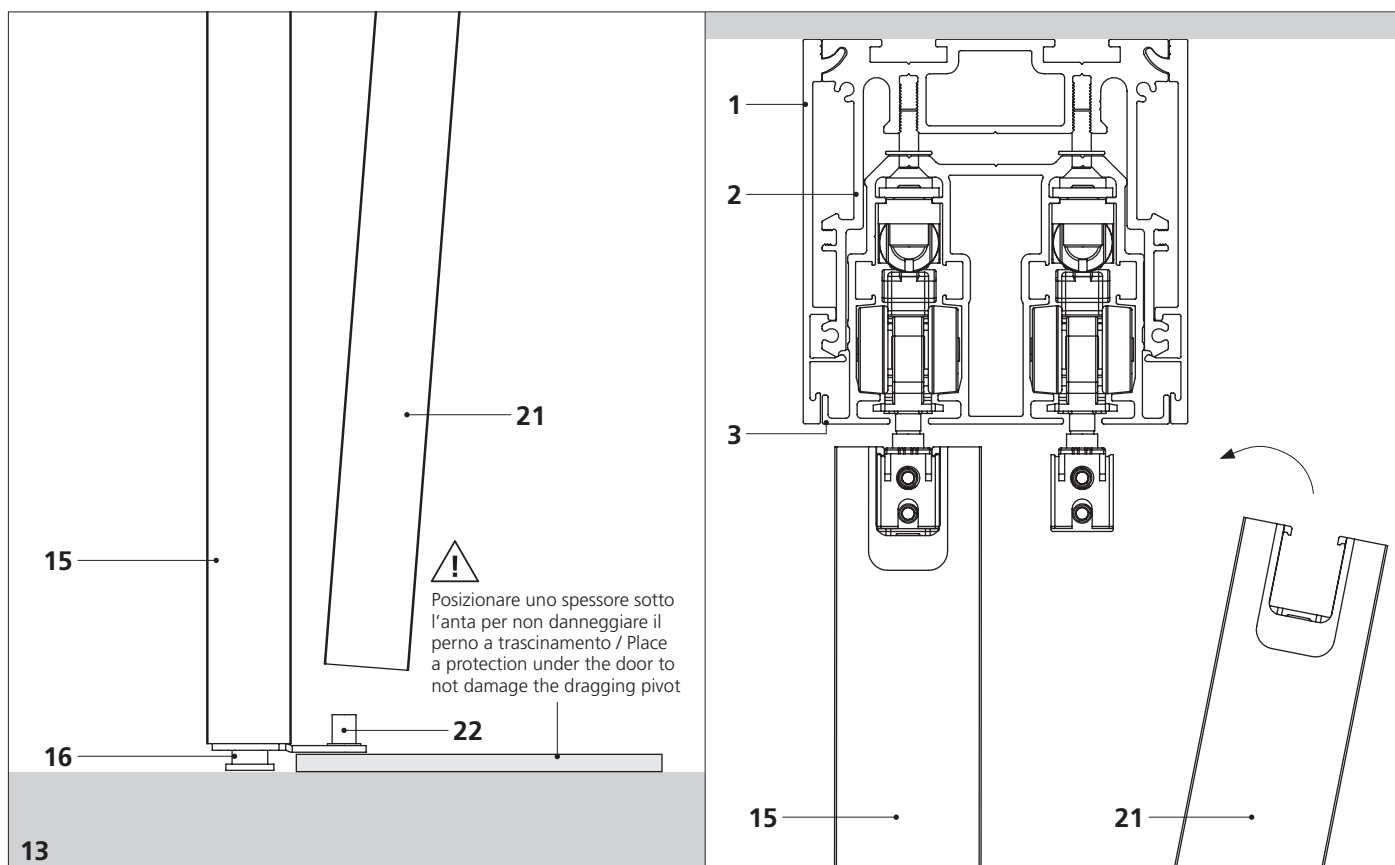

13. Calzare la seconda anta sul perno a trascinamento, sollevarla e avvicinarla ai carrelli inseriti nel binario.
 13. Insert the second door on the dragging pivot, lift it and bring it close to the carriages inserted in the beam.

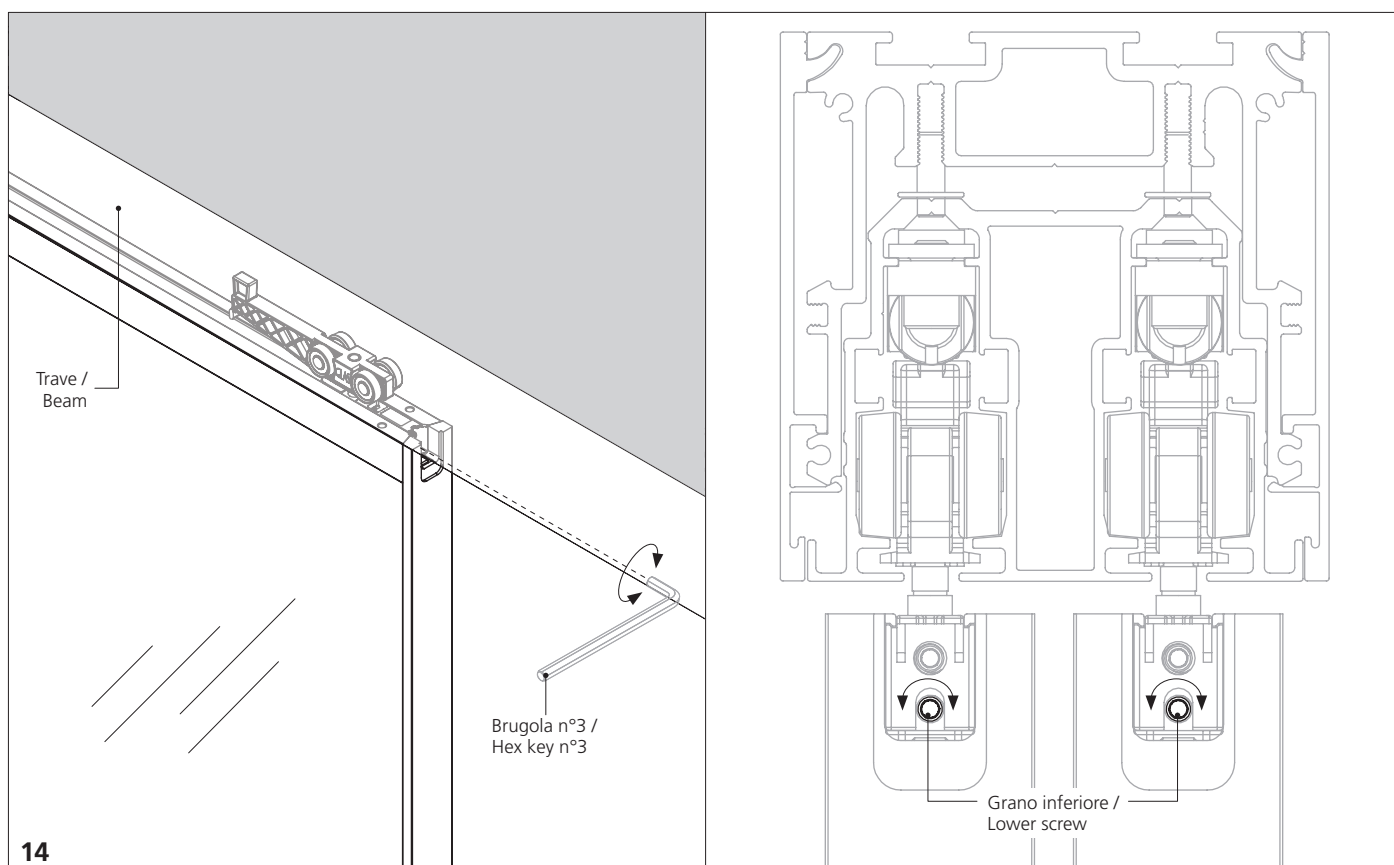

14. Avvitare il grano inferiore per bloccare il carrello.
14. Screw the lower grain to lock the carriage.

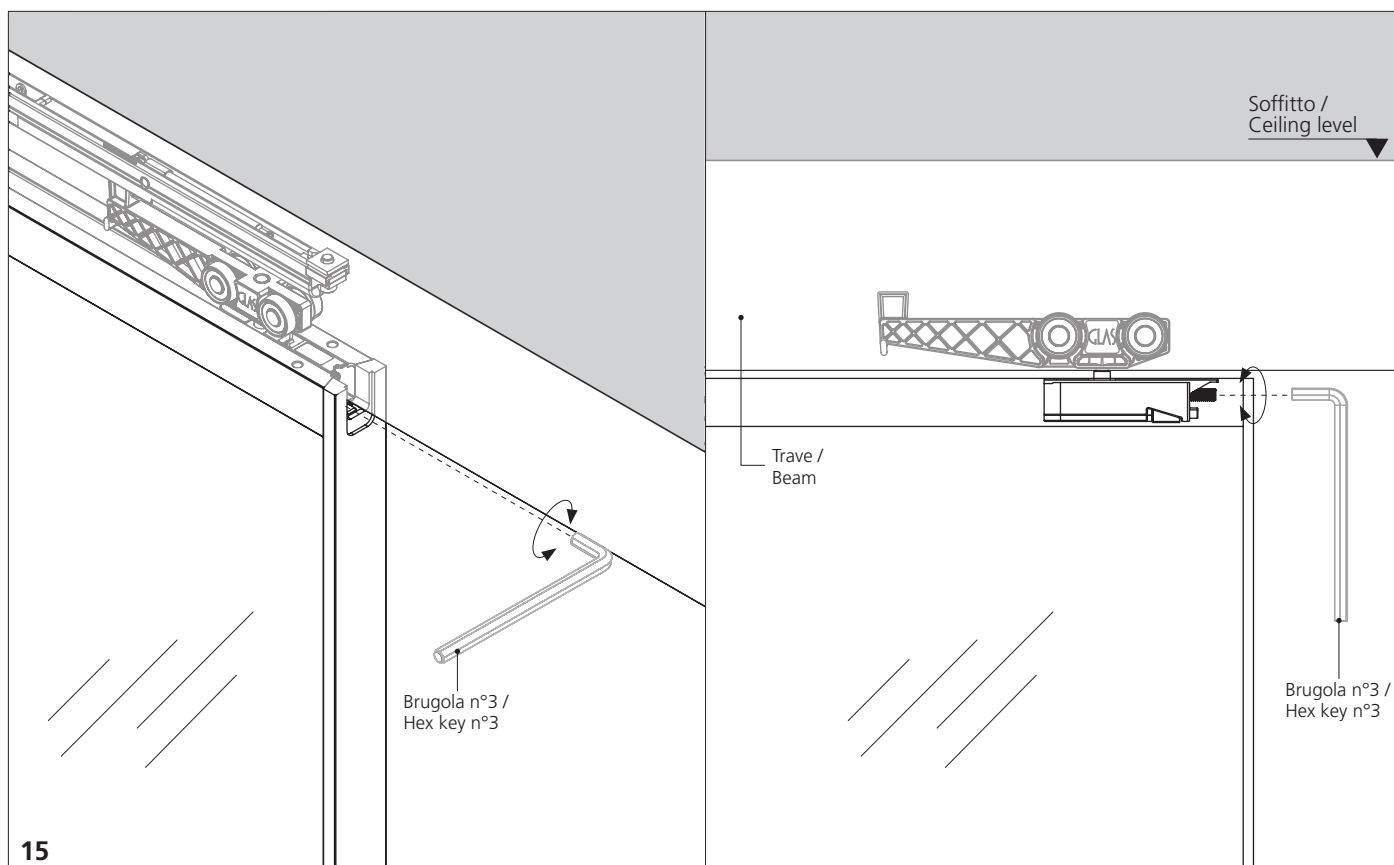

15. Per una regolazione millimetrica dell'anta, agire sulla vite superiore presente nel carrello di scorrimento.
15. To adjust the door millimetrically, act on the upper screw placed in the sliding carriage.

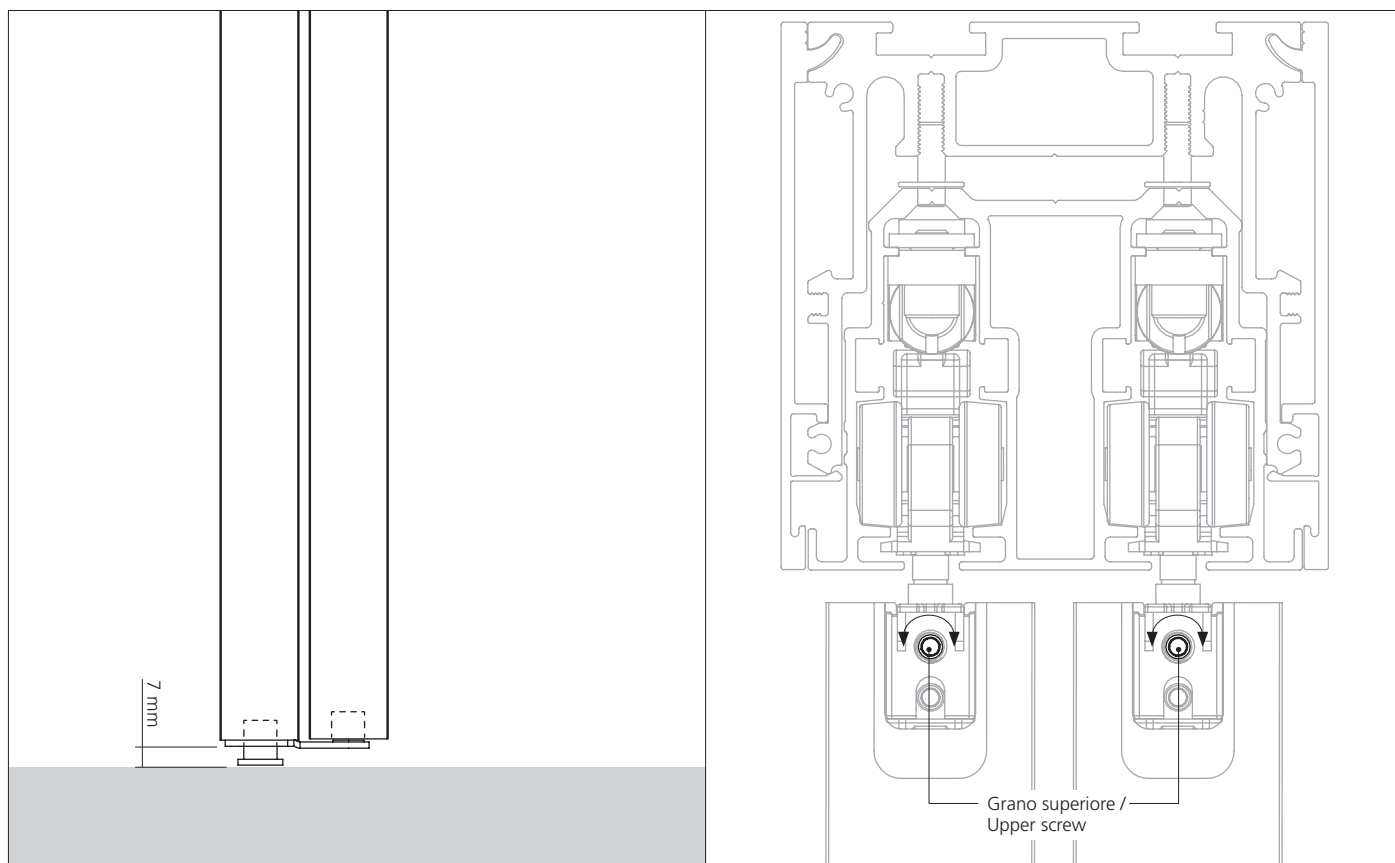

Misura ideale per lo scorrimento dell'anta.
Ideal measure for the door sliding.

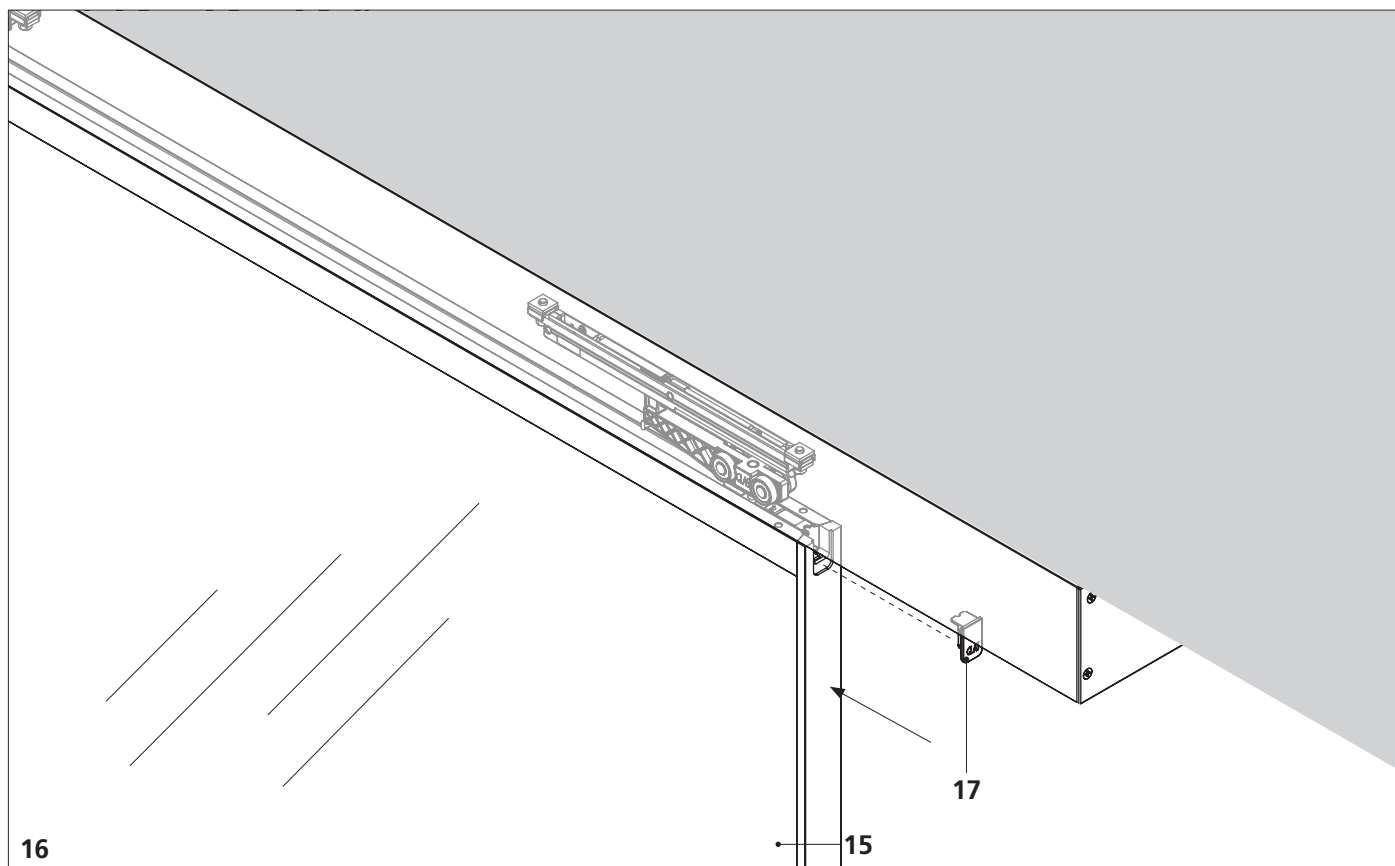

16. Posizionare a pressione il tappo copri carrello sulle ante.
16. Position the carriage cover cap on the doors by pressing.



SHERAZADE

**Sistema scorrevole | Anta fissa | Montaggio
Sliding system | Fixed door | Installation**

Installazione anta fissa / Fixed door installation

Configurazioni di montaggio / Installation configurations	pag.	1.103
Esploso componenti / Components exploded diagram	pag.	1.104
Installazione profilo a pavimento / Floor profile installation	pag.	1.108
Installazione anta / Door installation	pag.	1.112
Regolazione anta / Door adjustment	pag.	1.113
Posizionamento tappo con logo / Closure cap with logo positioning	pag.	1.114

ATTENZIONE: Per evitare rumori e vibrazioni durante lo scorrimento delle ante, le ruote dei carrelli e l'interno del binario devono essere perfettamente puliti.

AVERTISSEMENT : Pour éviter le bruit et les vibrations pendant le glissement des portes, les roues des chariots et l'intérieur du rail doivent être parfaitement propres.

ACHTUNG: um Geräusche und Vibrationen während des Gleitens der Türen zu vermeiden, sollen die Räder der Wagen und die Innerseite der Schiene perfekt sauber sein.

ATTENTION: To avoid noises and vibrations during the door's sliding, the wheels of the carriages and the inside of the rail must be perfectly clean.

ATENCIÓN: Para evitar ruidos y vibraciones durante el deslizamiento de las puertas, las ruedas de los carrillos y el interior de la guía tienen que ser perfectamente limpios.

Configurazione anta fissa (con profilo tubolare a pavimento) con anta scorrevole /
Fixed door (with floor tubular profile) with sliding door configuration

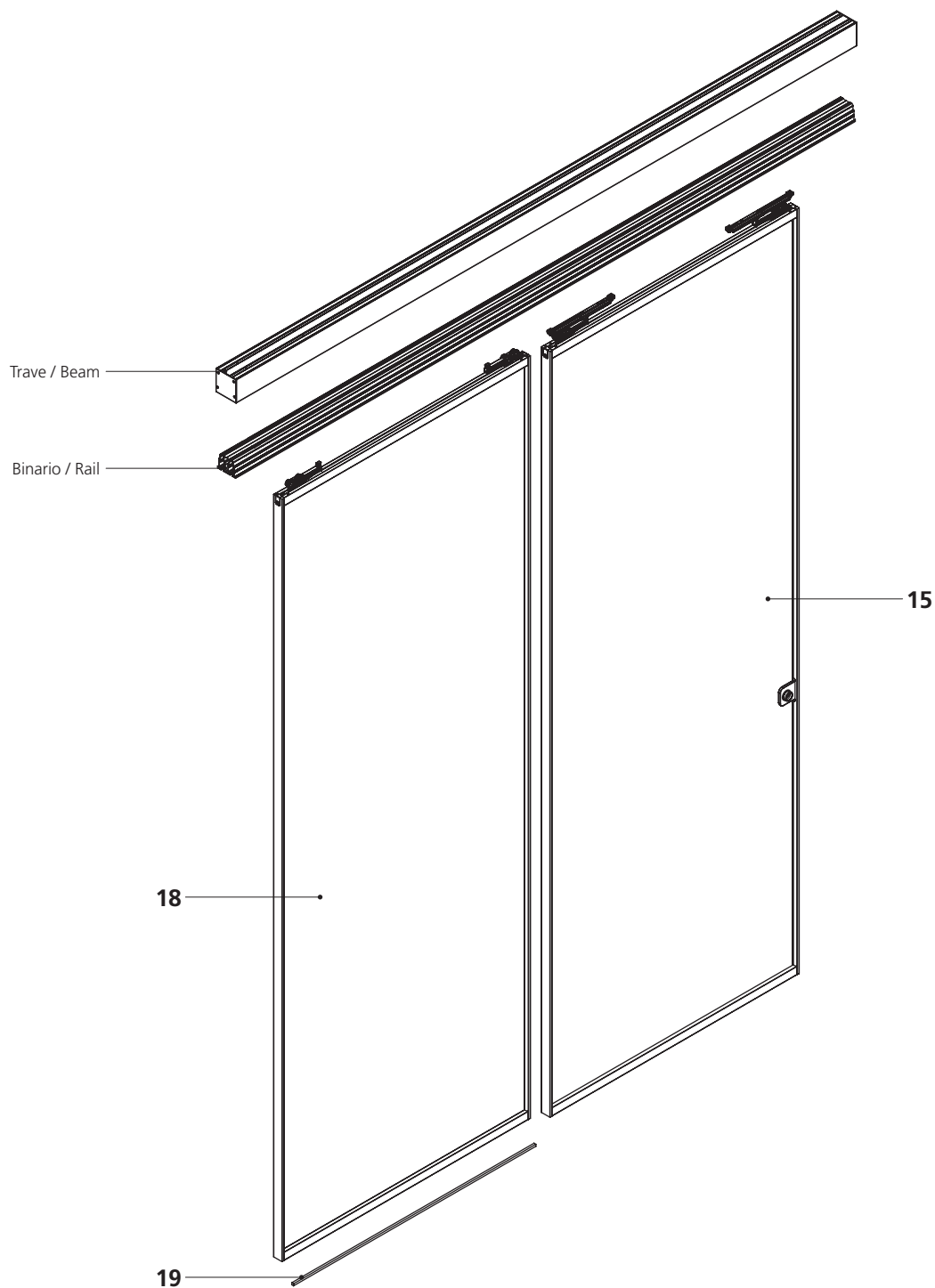

Verificare il tipo di configurazione: / Check the correct configuration:

Configurazione A / Configuration A

Anta fissa destra / Right fixed door

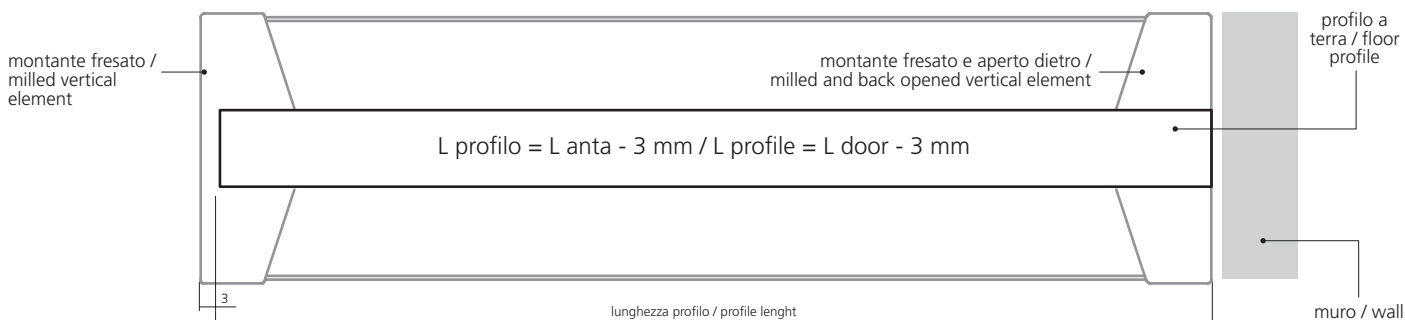

Configurazione B / Configuration B

Anta fissa sinistra / Left fixed door

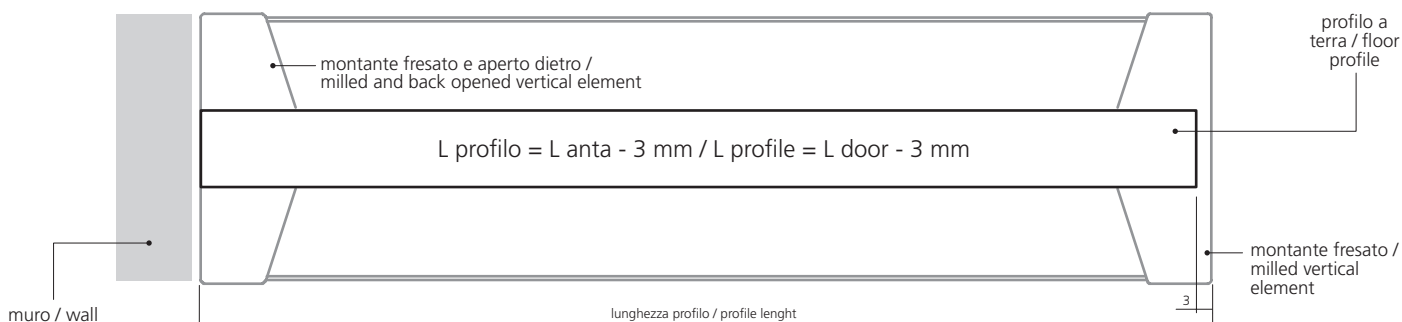

Configurazione C / Configuration C

Anta fissa centrale / Central fixed door

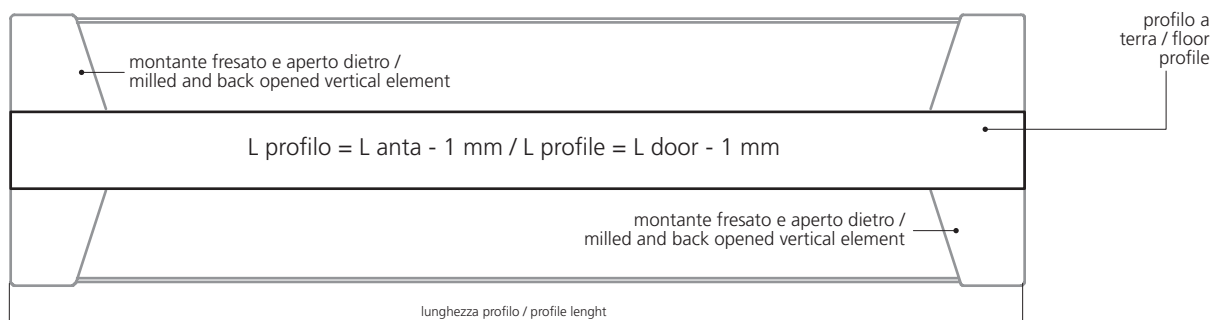

Configurazione D / Configuration D

Anta fissa centrale singola / Single central fixed door

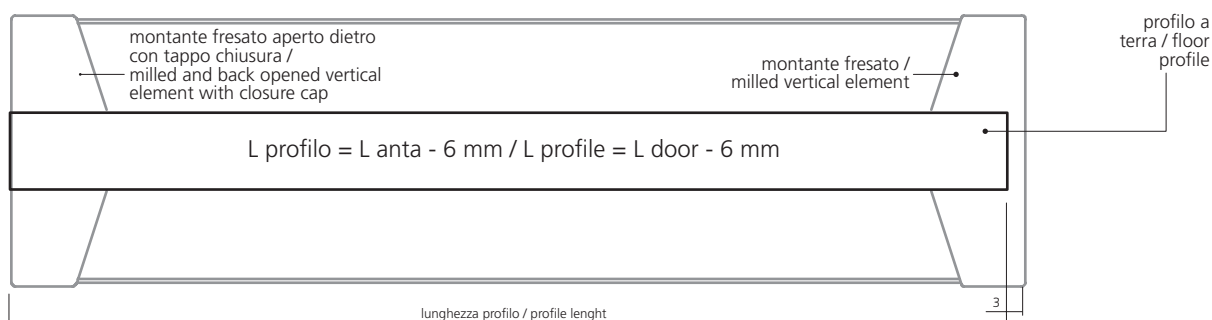

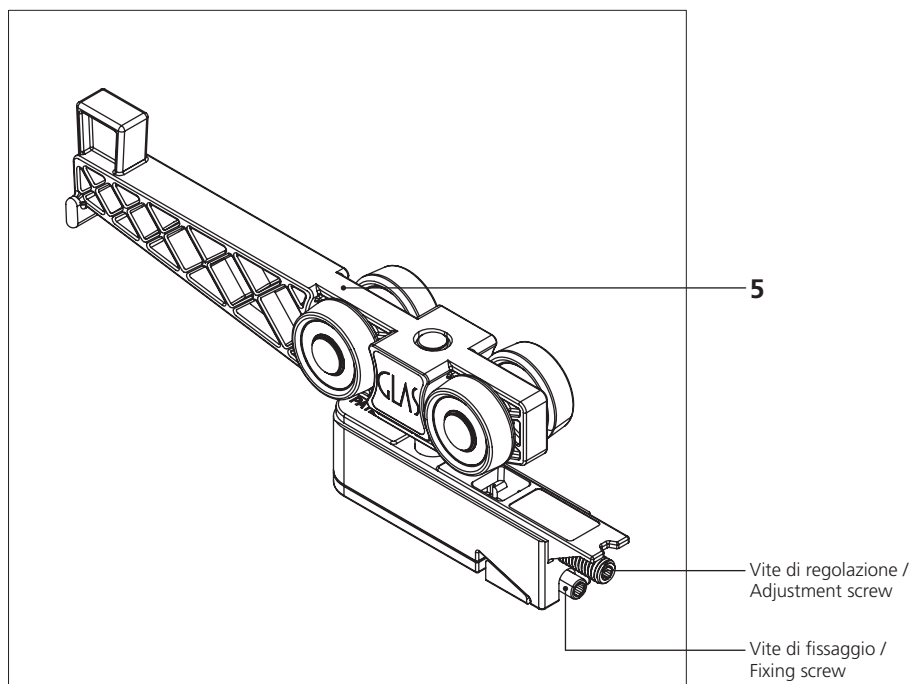

- 1b. Carter di finitura / Finishing case
- 2. Trave / Beam
- 3. Binario / Rail
- 4. Staffa / Bracket
- 5. Carrello / Carriage
- 6. Rallentatore (versione destra e sinistra) / Slow motion device (left and right version)
- 8. Fermo per anta fissa / Stopper for fixed door
- 15. Anta mobile / Sliding door
- 16. Perno a pavimento / Floor pivot
- 17. Tappo con logo / Closure cap with logo
- 18. Anta fissa / Fixed door
- 19. Profilo per anta fissa / Profile for fixed door

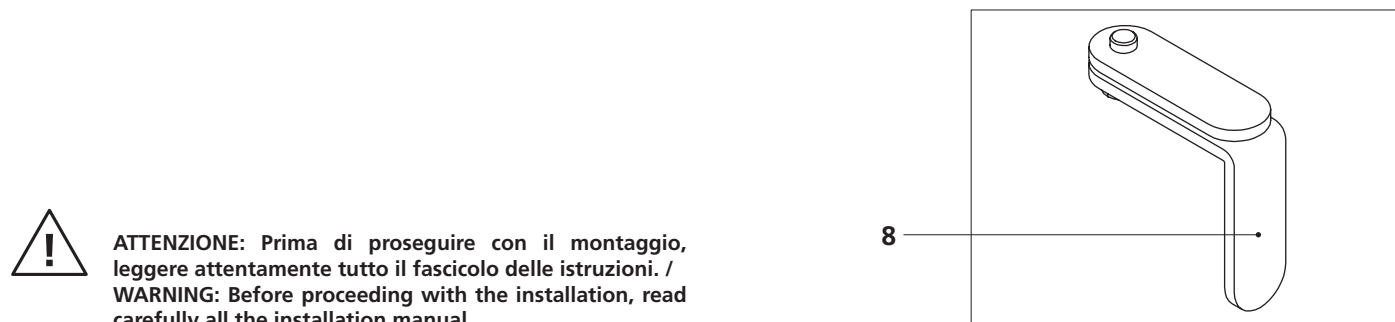
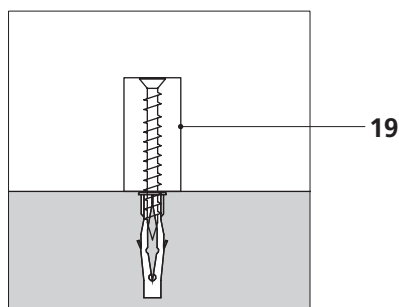

ATTENZIONE: Prima di proseguire con il montaggio, leggere attentamente tutto il fascicolo delle istruzioni. / **WARNING:** Before proceeding with the installation, read carefully all the installation manual.

Simbologia e strumenti di montaggio / Symbology and assembly tools



Fare attenzione/
Pay attention



Avvicinare - togliere/
Bring closer - Remove



In squadra/
At right angle



Allineare/
Align



Avvitare-regolare/
Screw-adjust



Inserisci/
Insert



Quota/
Level

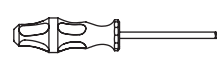

Cacciavite a croce/
Crosshead screwdriver



Chiave a brugola/
Hex key

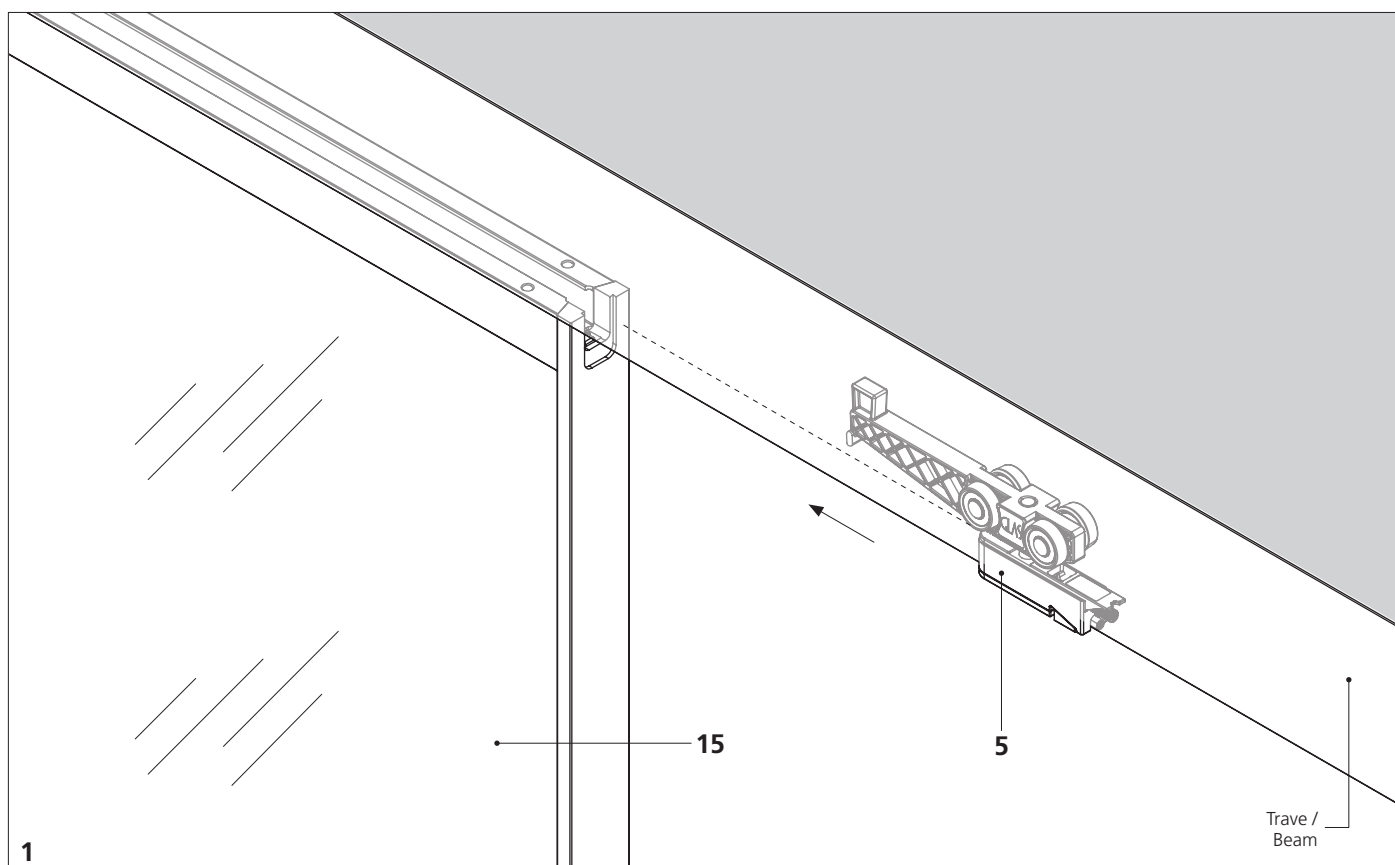

1. Agganciare le ante ai carrelli.
1. Hook the doors to the sliding carriages.

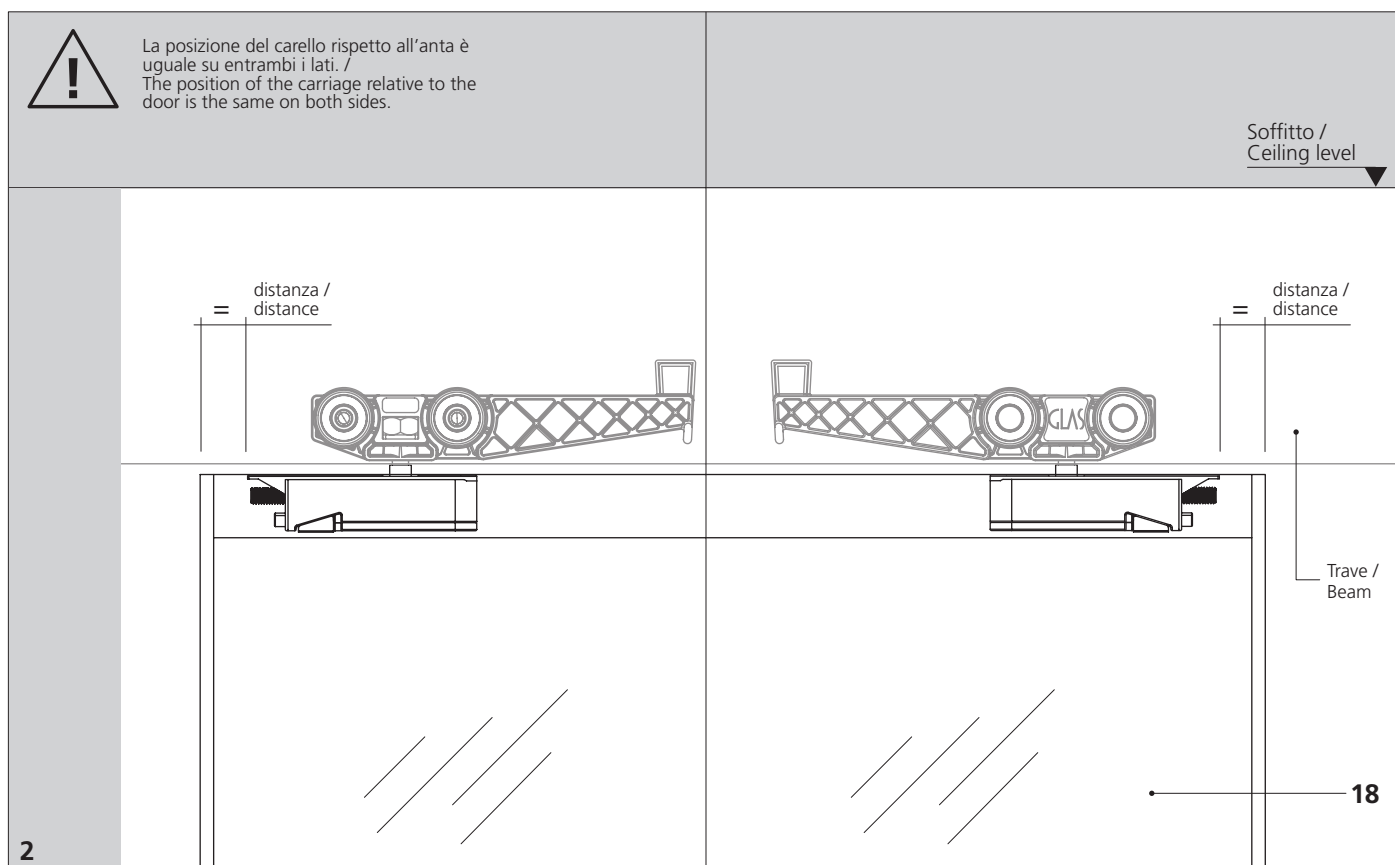

2. La lavorazione presente sul traverso dell'anta identifica la posizione del carrello rispetto al bordo dell'anta stessa.
2. Machining on the door's crosspiece identifies the position of the carriage in relation to the door's edge.

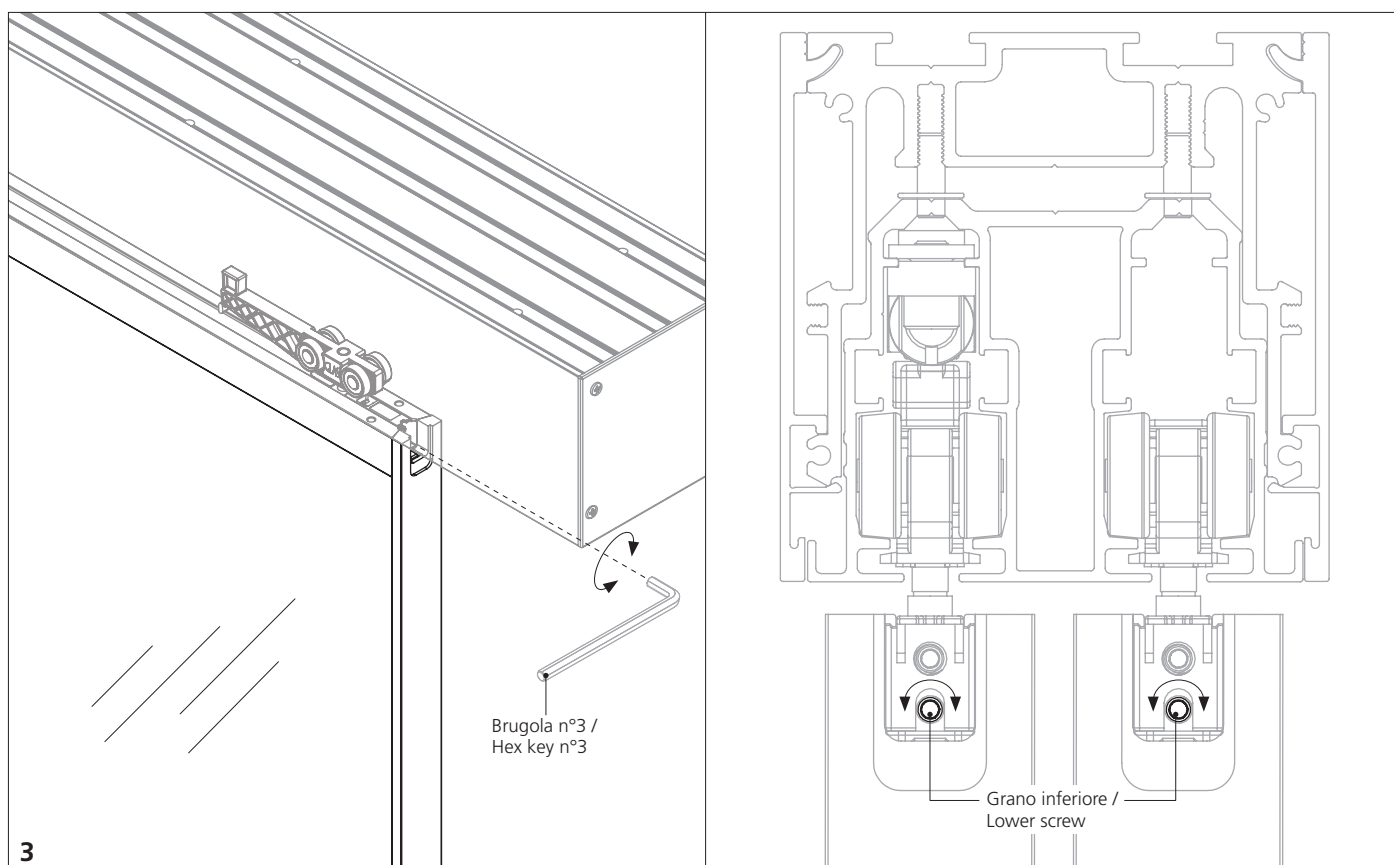

3. Avvitare il grano inferiore per bloccare il carrello. Ripetere i passaggi da n°1 a 3 per tutte le ante.
3. Screw the lower grain to block the carriage. Repeat the steps from n° 1 to 3 for all doors.

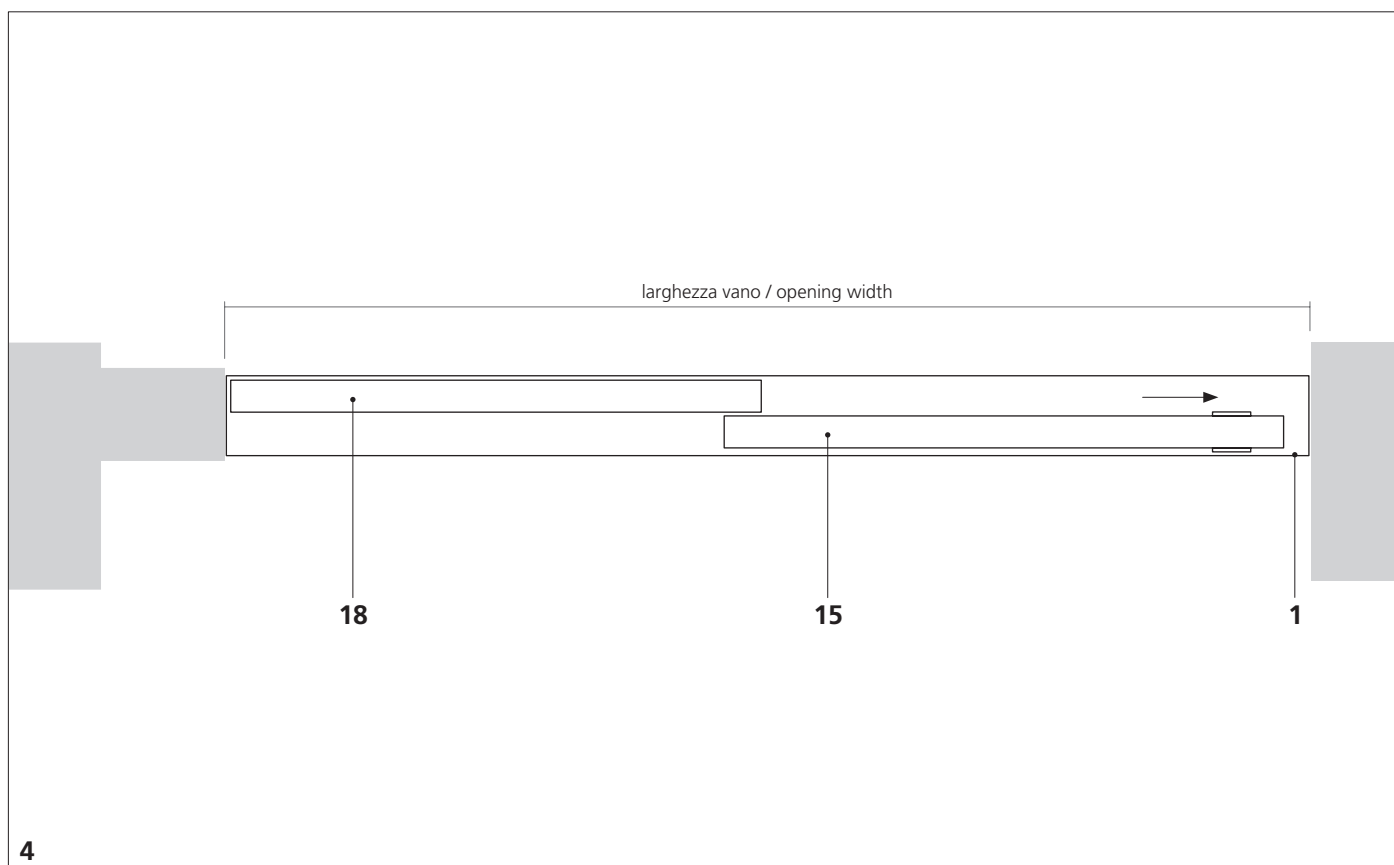

4. Posizionare le ante nella posizione di chiusura.
4. Place the doors in the closing position.

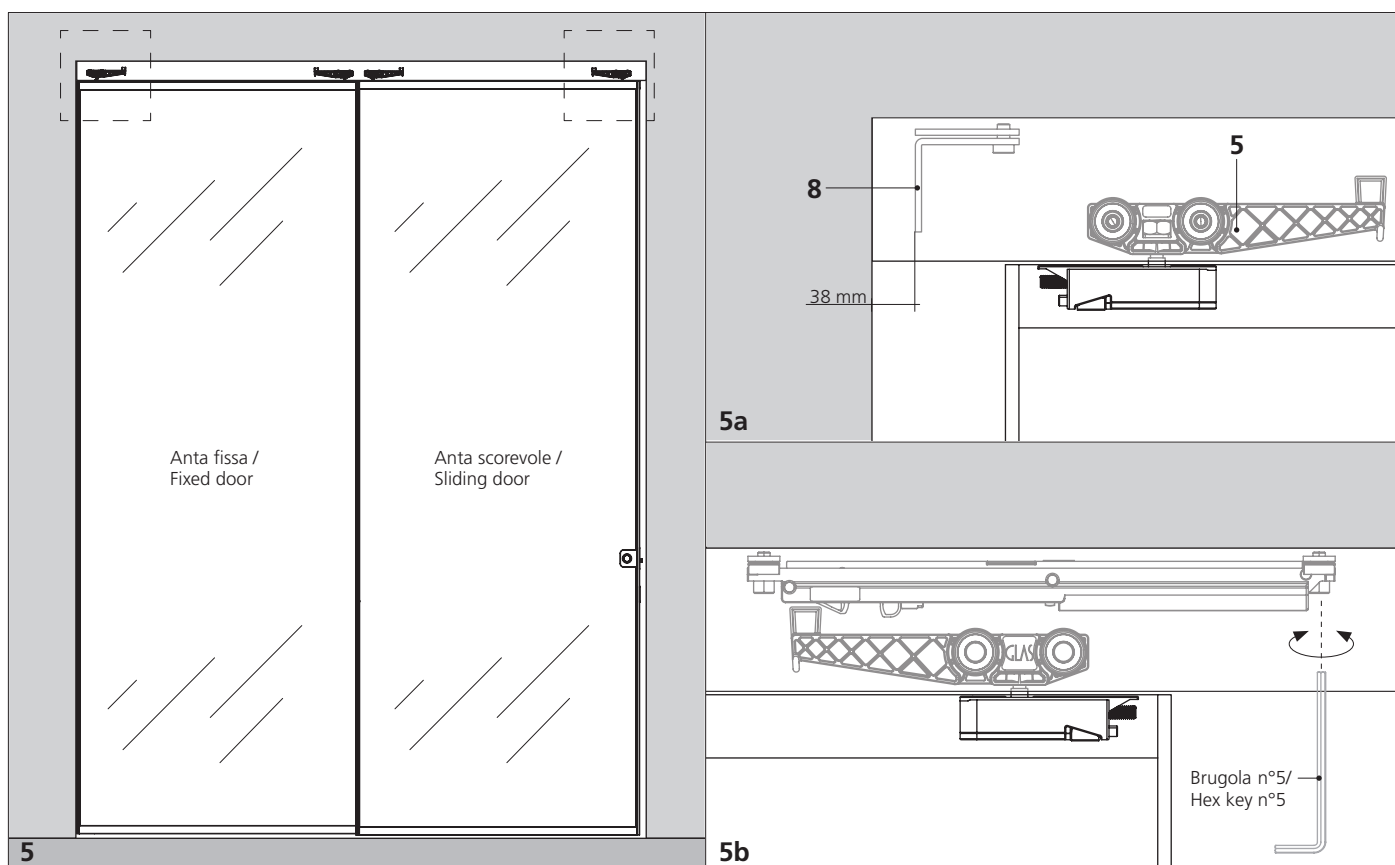

5. Verificare la distanza tra muro e fermo anta e successivamente posizionare i fermi e rallentatori nella posizione corretta.
 5. Check the distance between the wall and the door stop and then fix stops and slow motion devices in the correct position.

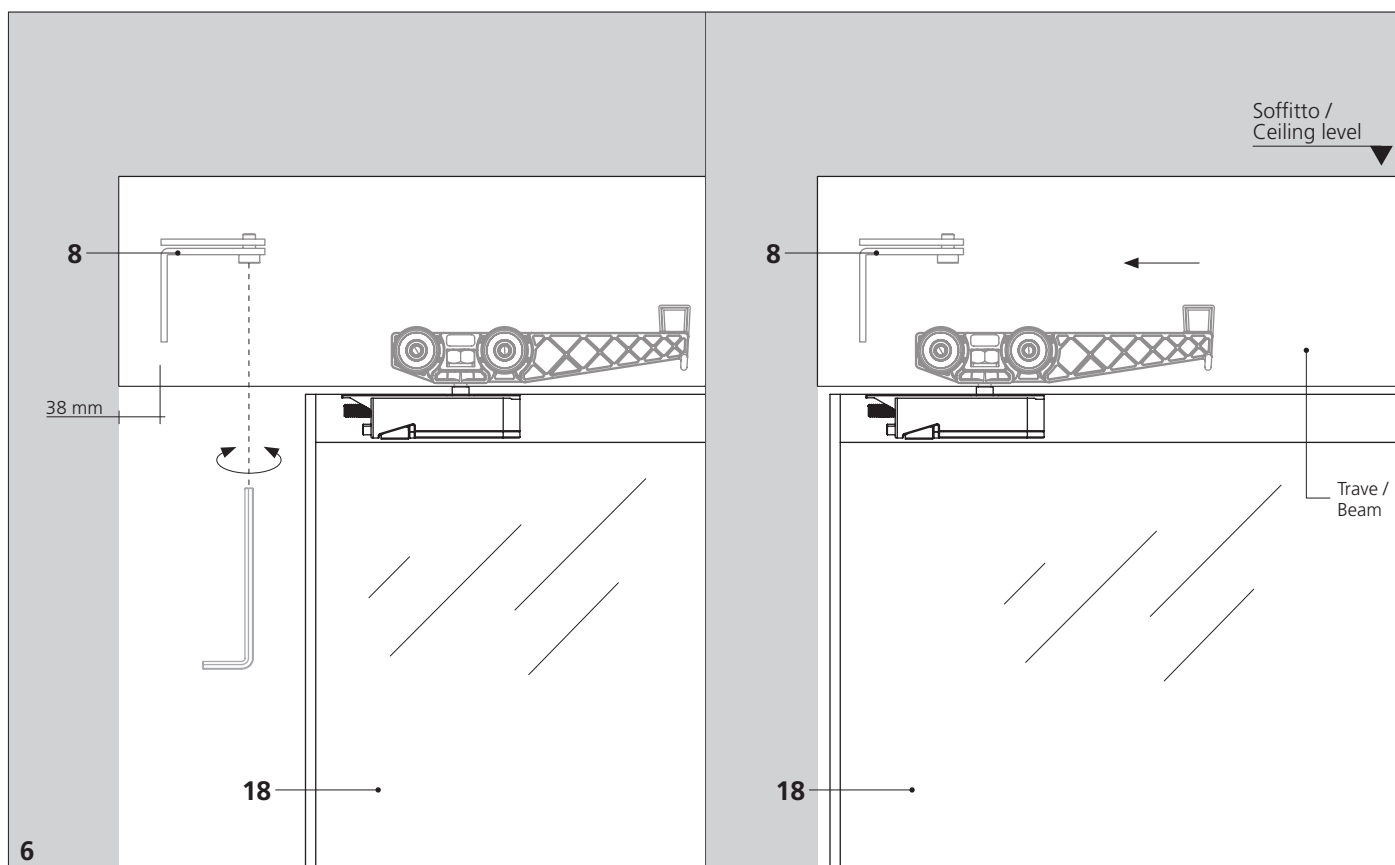

6. Spostare l'anta per poter avvitare le viti di fissaggio dei fermi, mantenendo la distanza (38mm) tra fermo [8] e muro.
 6. Move the door to screw the fixing screw of the stops, keeping the distance (38mm) between the stop [8] and the wall.

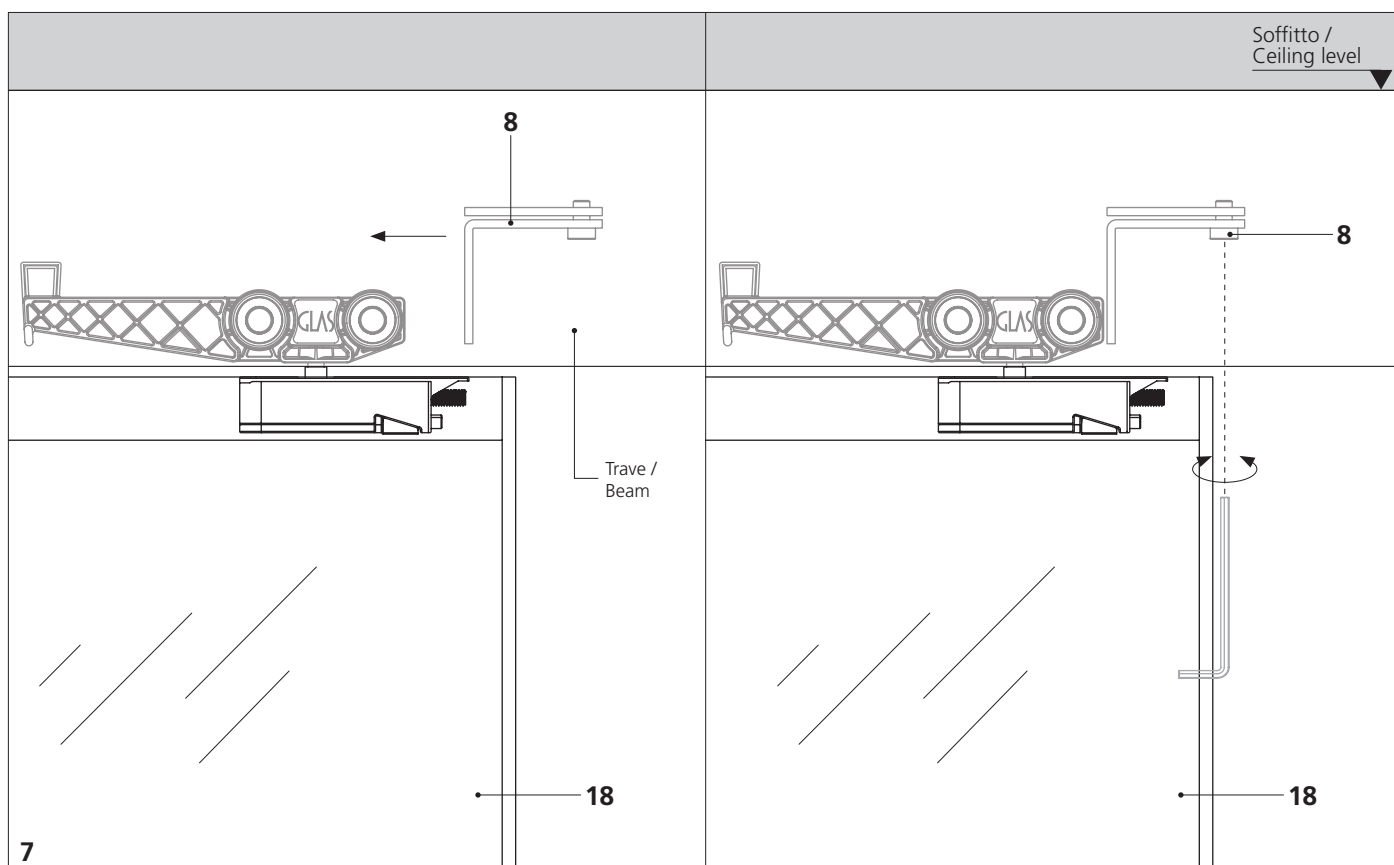

7. Agganciare il blocco al carrello e fissarlo in posizione.
 7. Hook the block to the carriage and fix it in position.

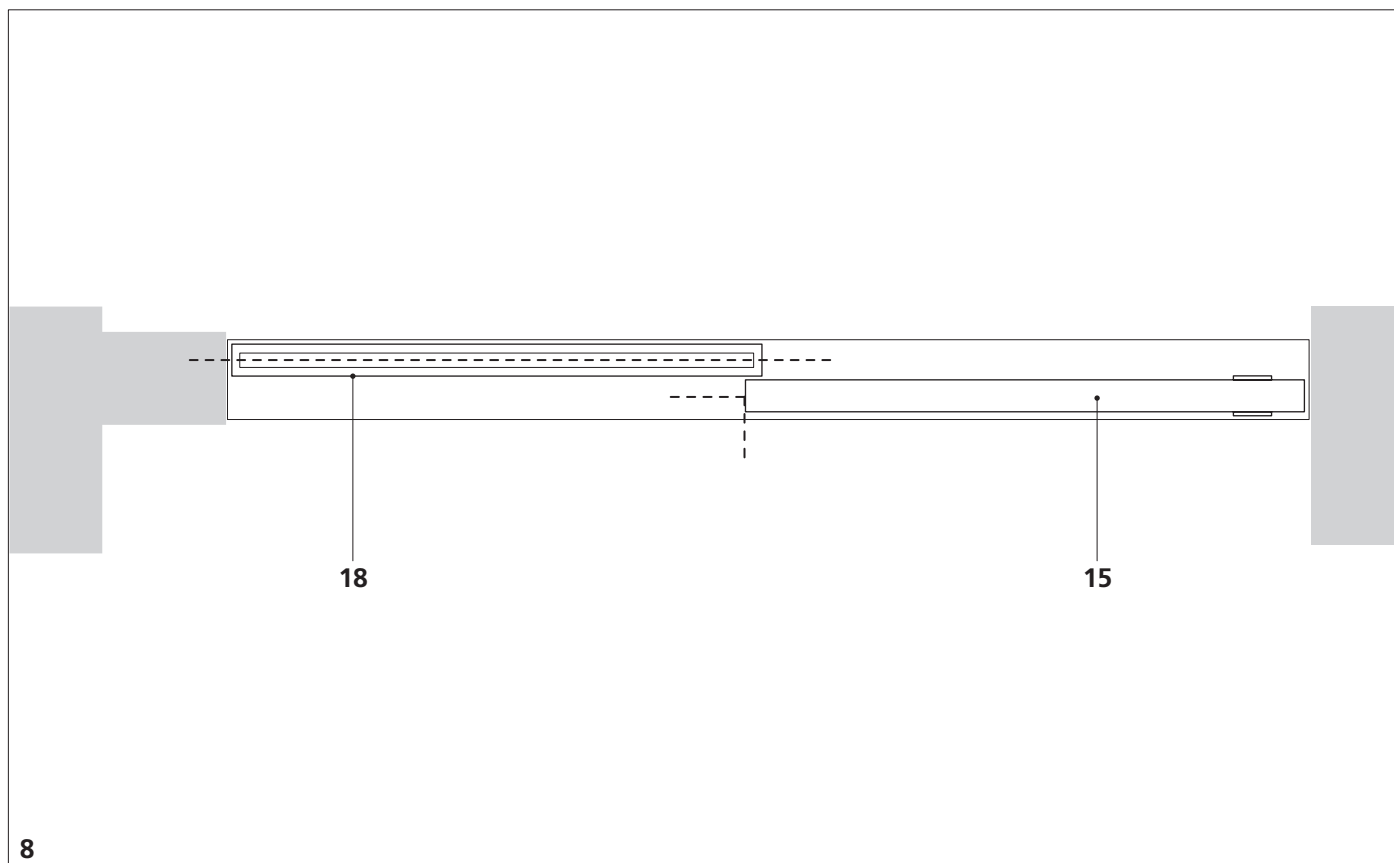

8. Chiudere le ante e segnare la posizione dell'anta per posizionare il profilo tubolare e il perno a pavimento.
 8. Close the doors and mark the door position to place the tubular profile and the floor pivot.

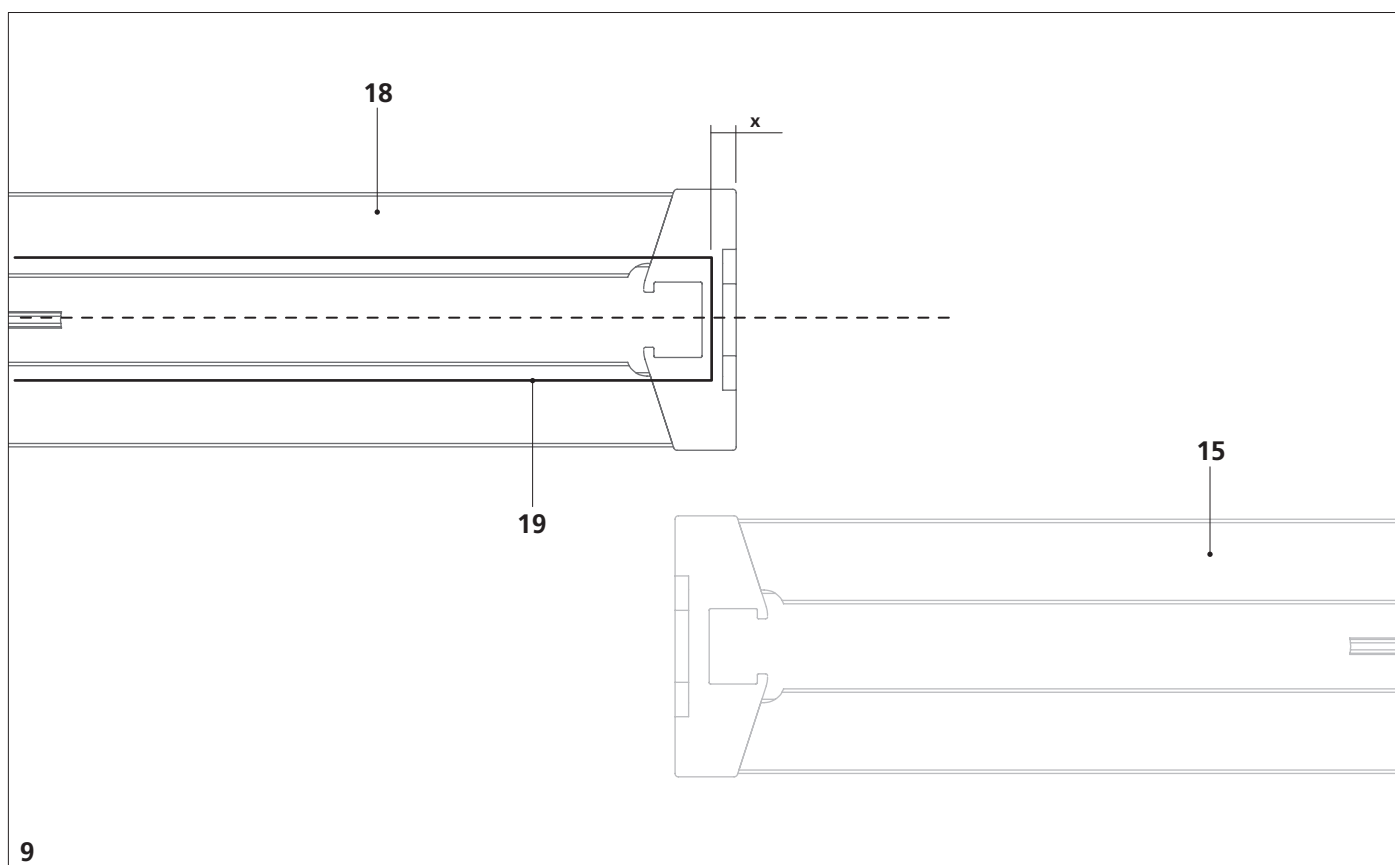

9. Il profilo deve essere posizionato in centro all'anta e a una distanza [x] dal bordo posteriore (controllare la configurazione a pagina 1.620).
9. The profile has to be placed in the middle of the door and at a distance [x] from the rear edge. (check the configuration on page 1.620).

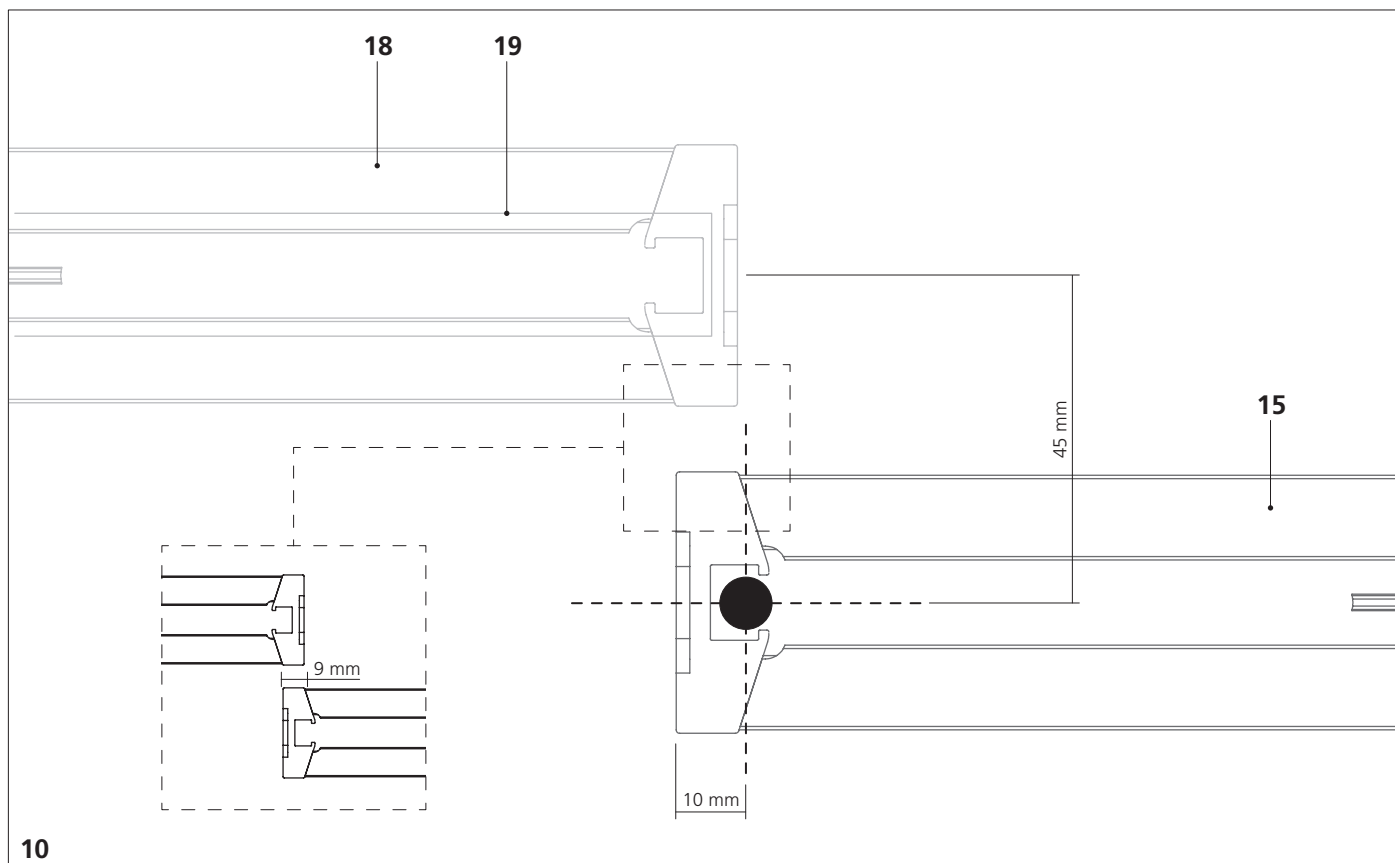

10. Il perno (per l'anta scorrevole) deve essere posizionato in centro all'anta e a 10 mm dal bordo posteriore.
10. The floor pivot (for sliding door) has to be placed in the middle of the door and at 10mm from the rear edge.

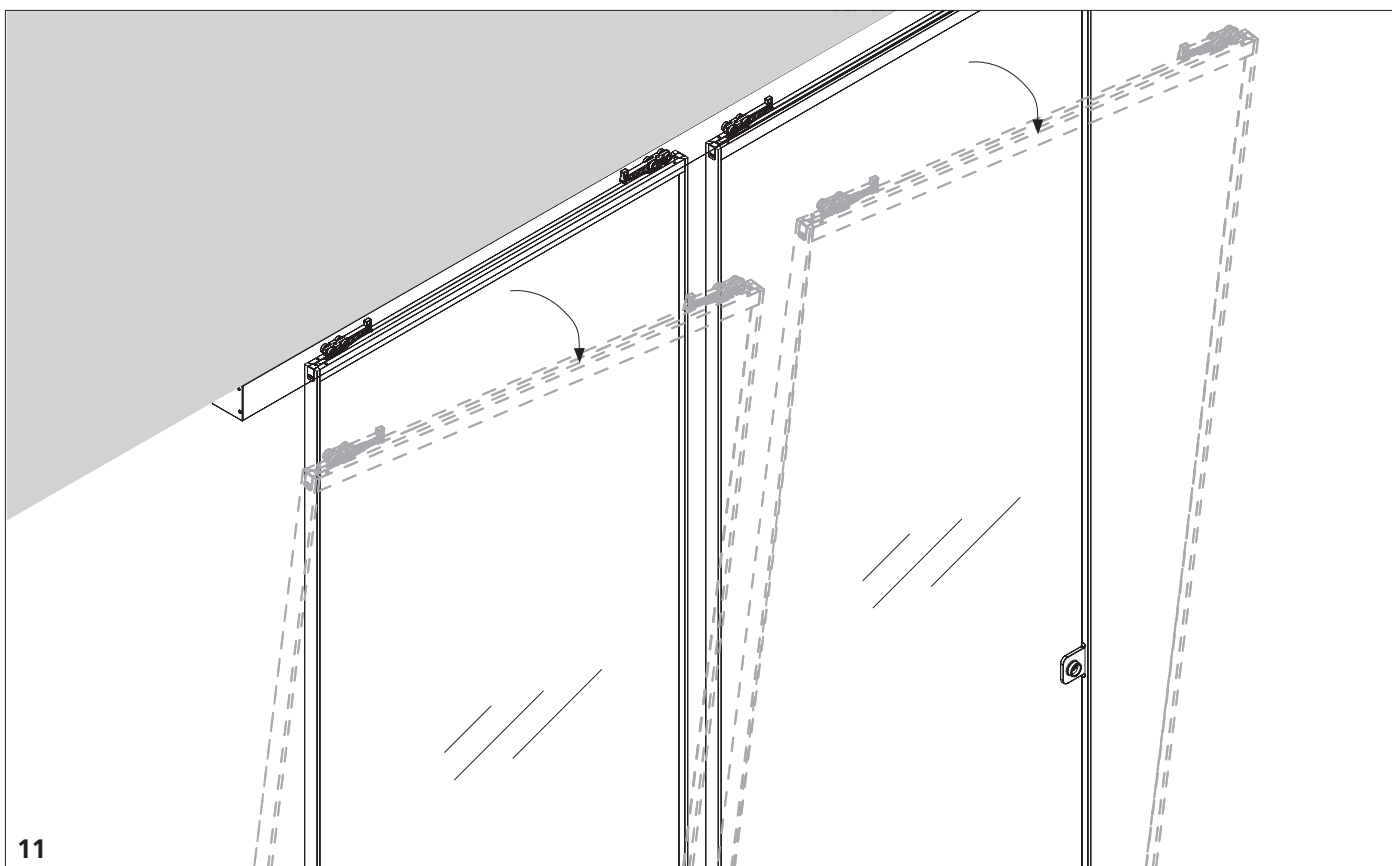

11. Svitare i carrelli e togliere tutte le ante.
11. Unscrew the carriages and remove all the doors.

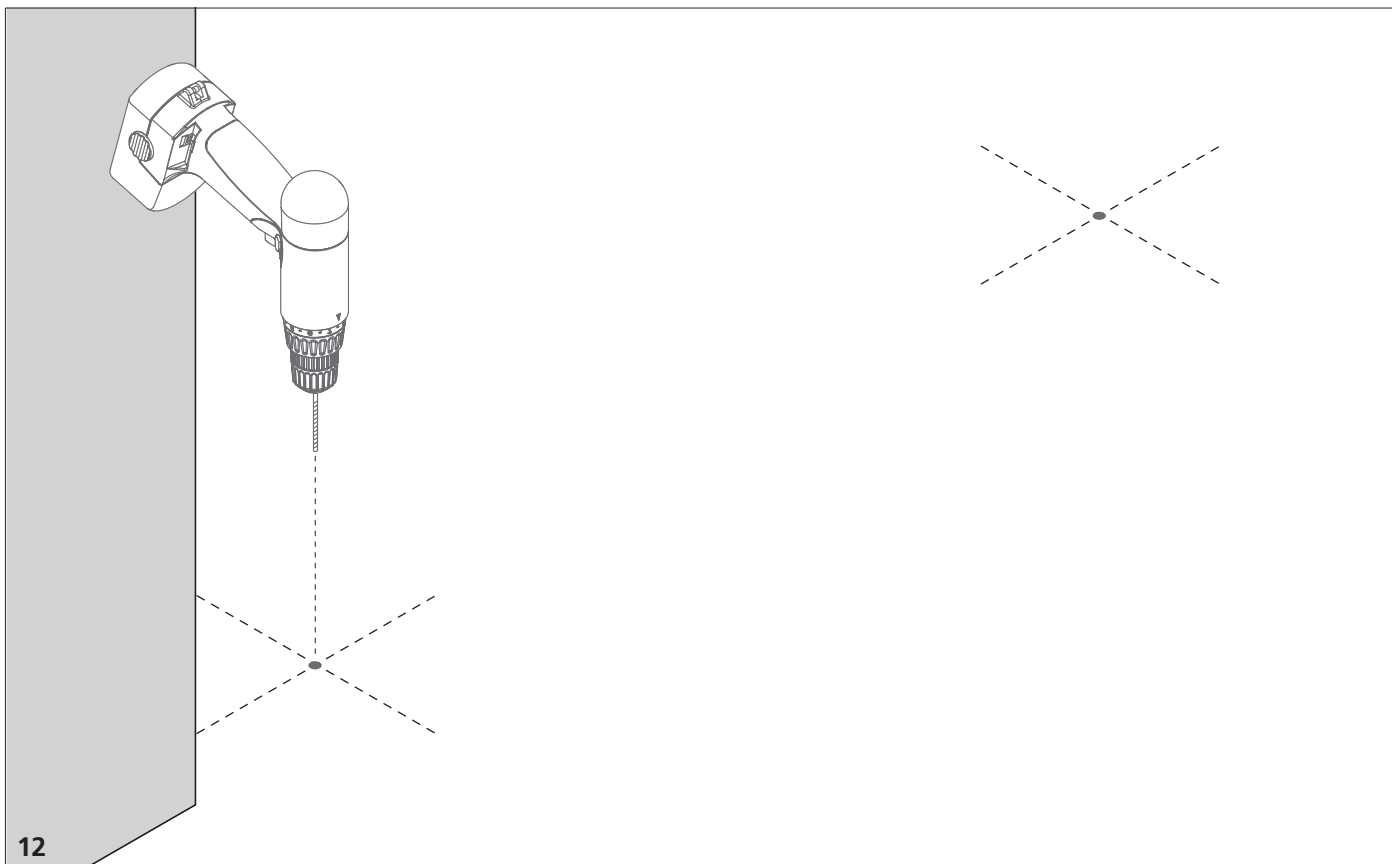

12. Forare nei punti prestabiliti.
12. Drill the floor in predetermined points.

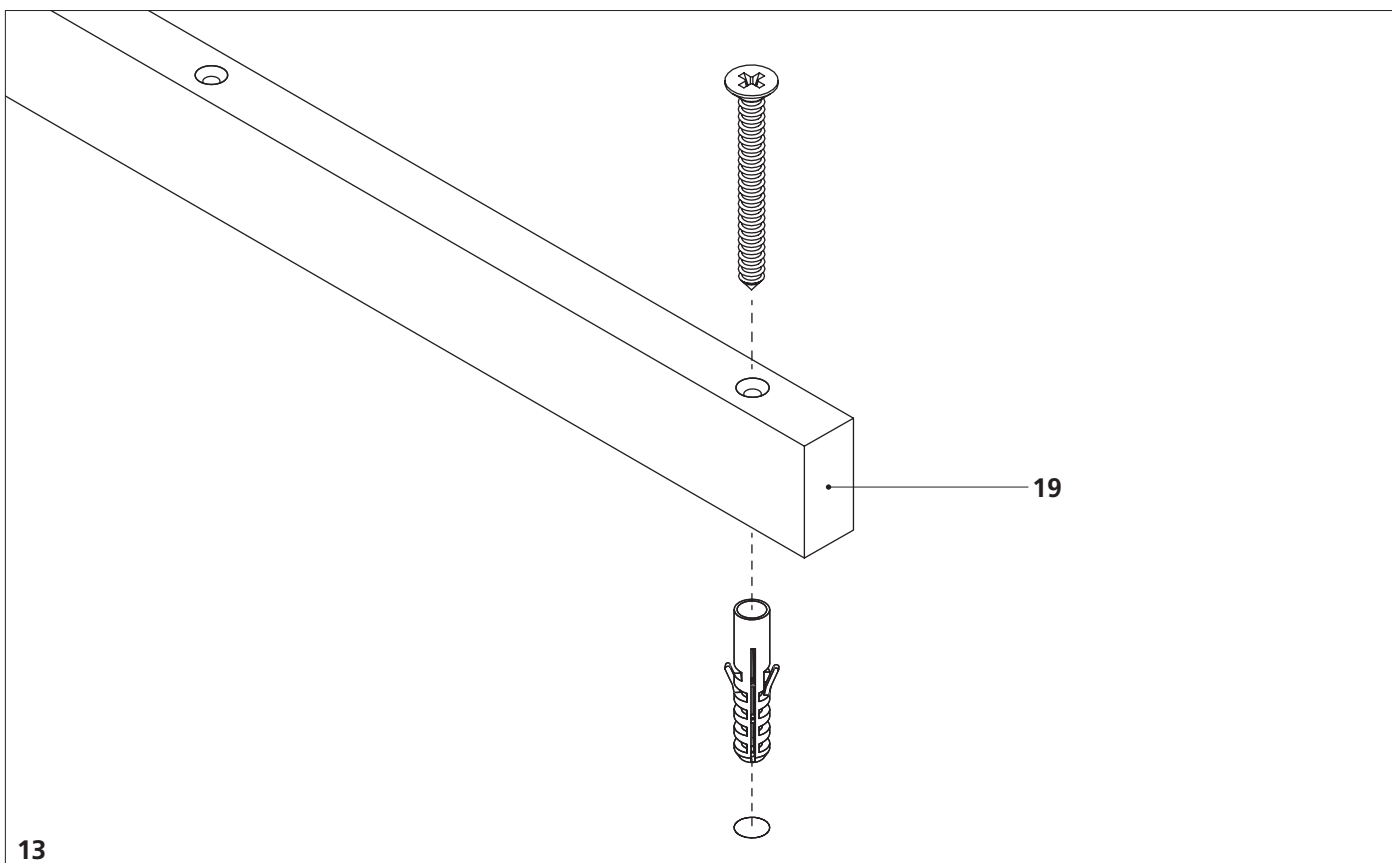

13 Fissare il profilo tubolare al pavimento.
13. Fix the tubular profile to the floor.

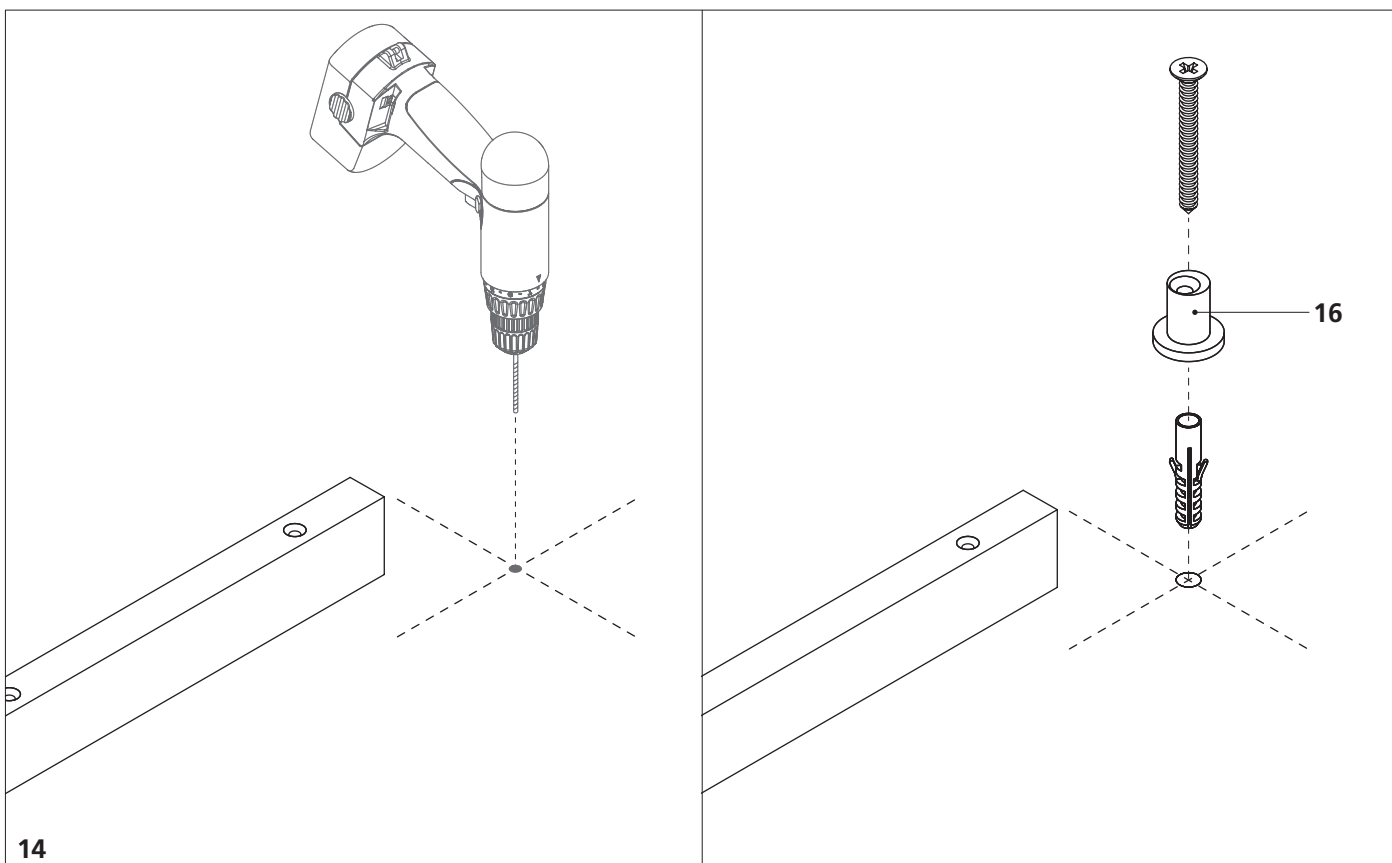

14. Forare e fissare il perno a pavimento.
14. Drill and fix the floor pivot to the floor.

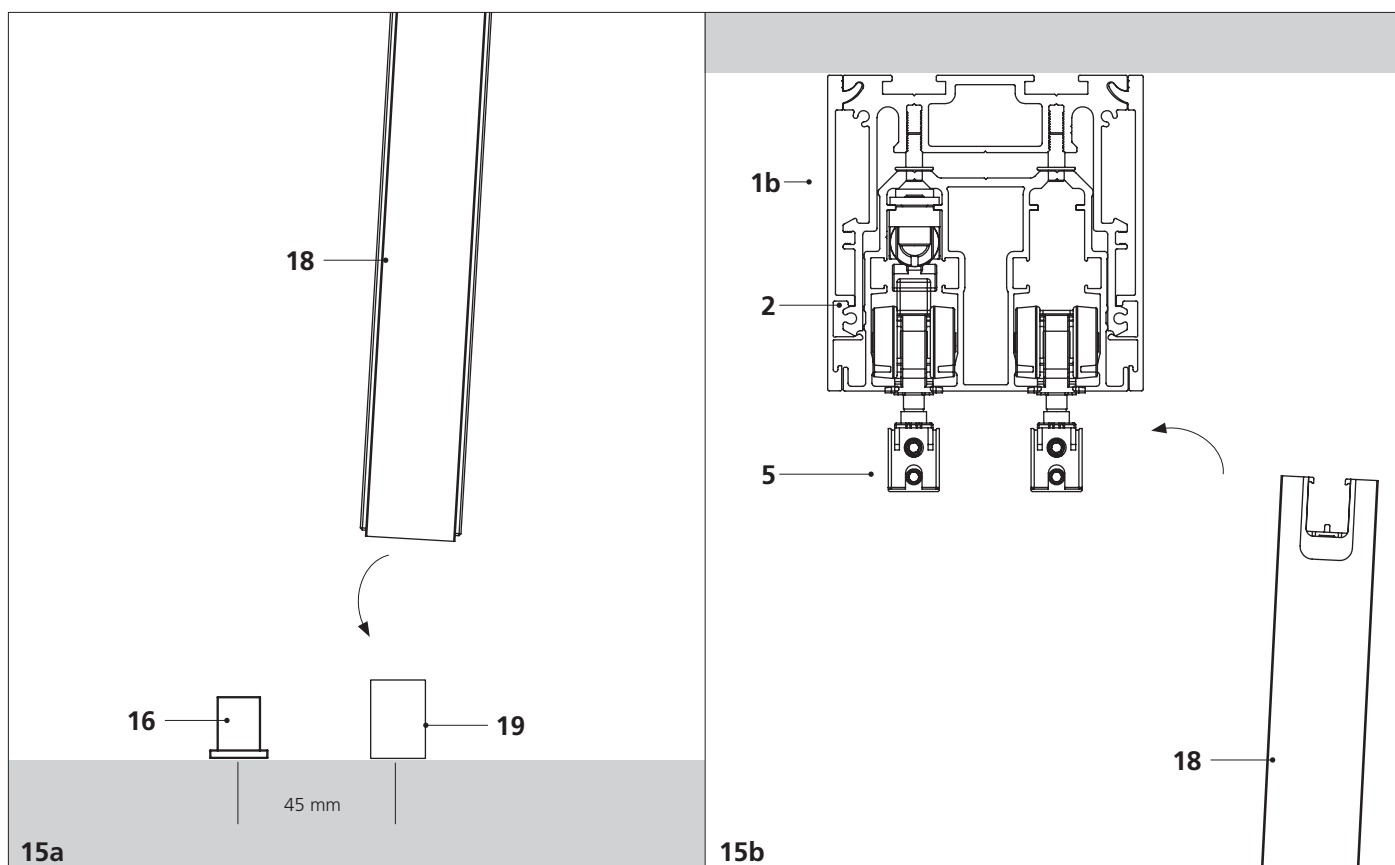

15. Calzare l'anta fissa sul profilo fissato a pavimento, sollevarla e avvicinarla ai carrelli inseriti nel binario.
 15. Insert the fixed door on the profile fixed to the floor, lift it and bring it close to the carriages inserted in the beam.

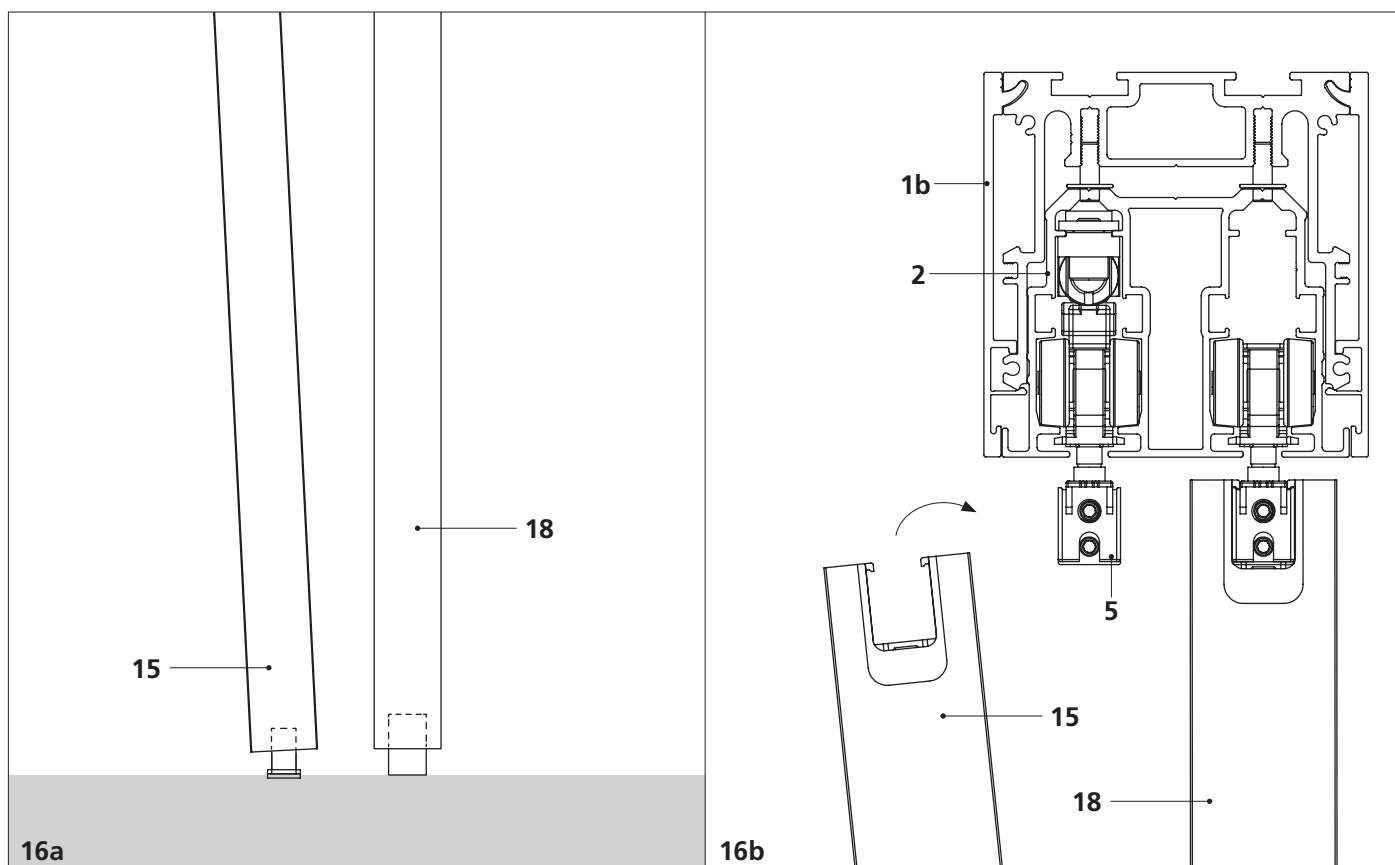

16. Calzare l'anta sul perno, sollevarla e avvicinarla ai carrelli inseriti nel binario.
 16. Insert the door on the floor pivot, lift it and bring it close to the carriages inserted in the beam.

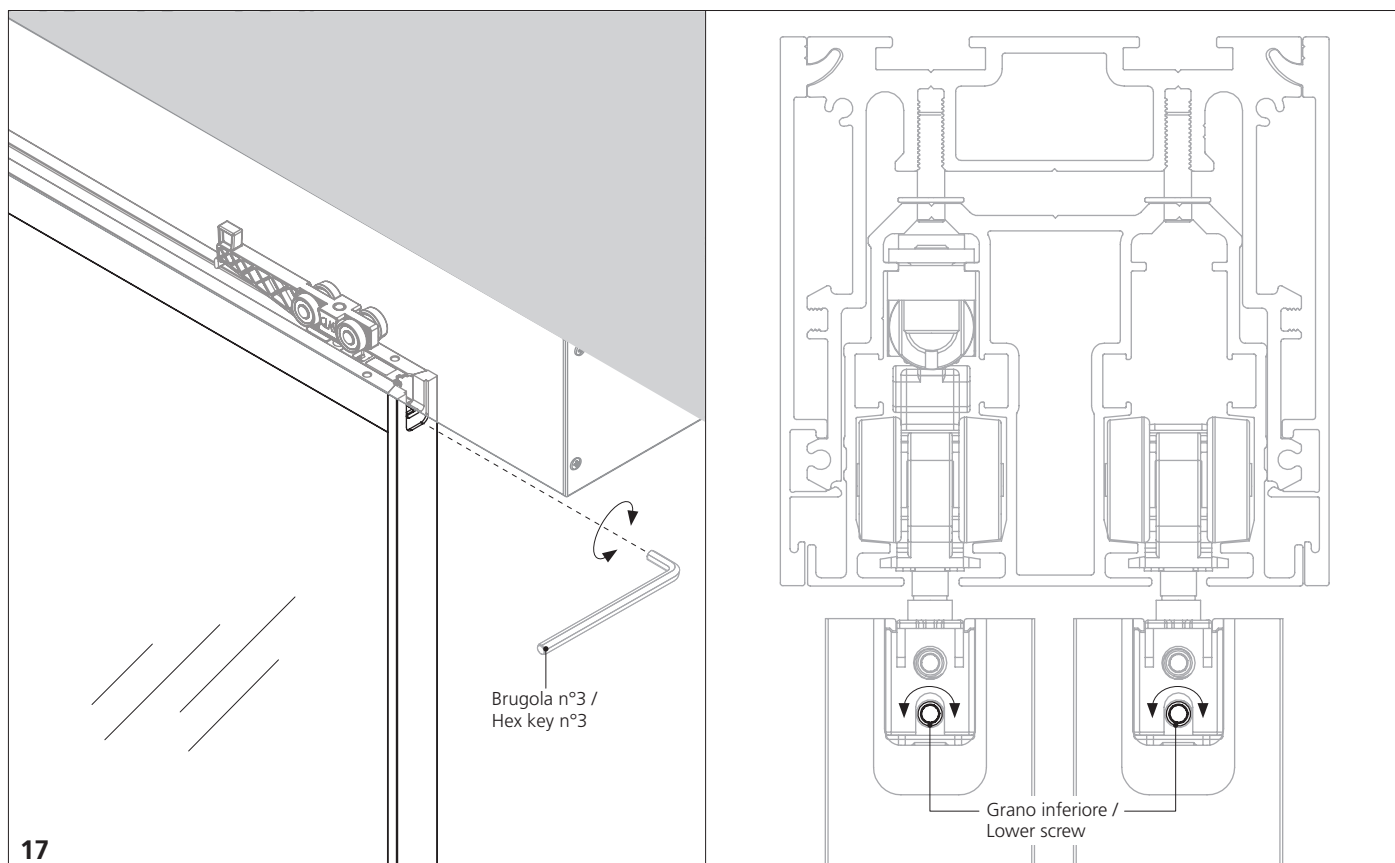

17. Avvitare il grano inferiore per bloccare il carrello.
17. Screw the lower grain to block the carriage.

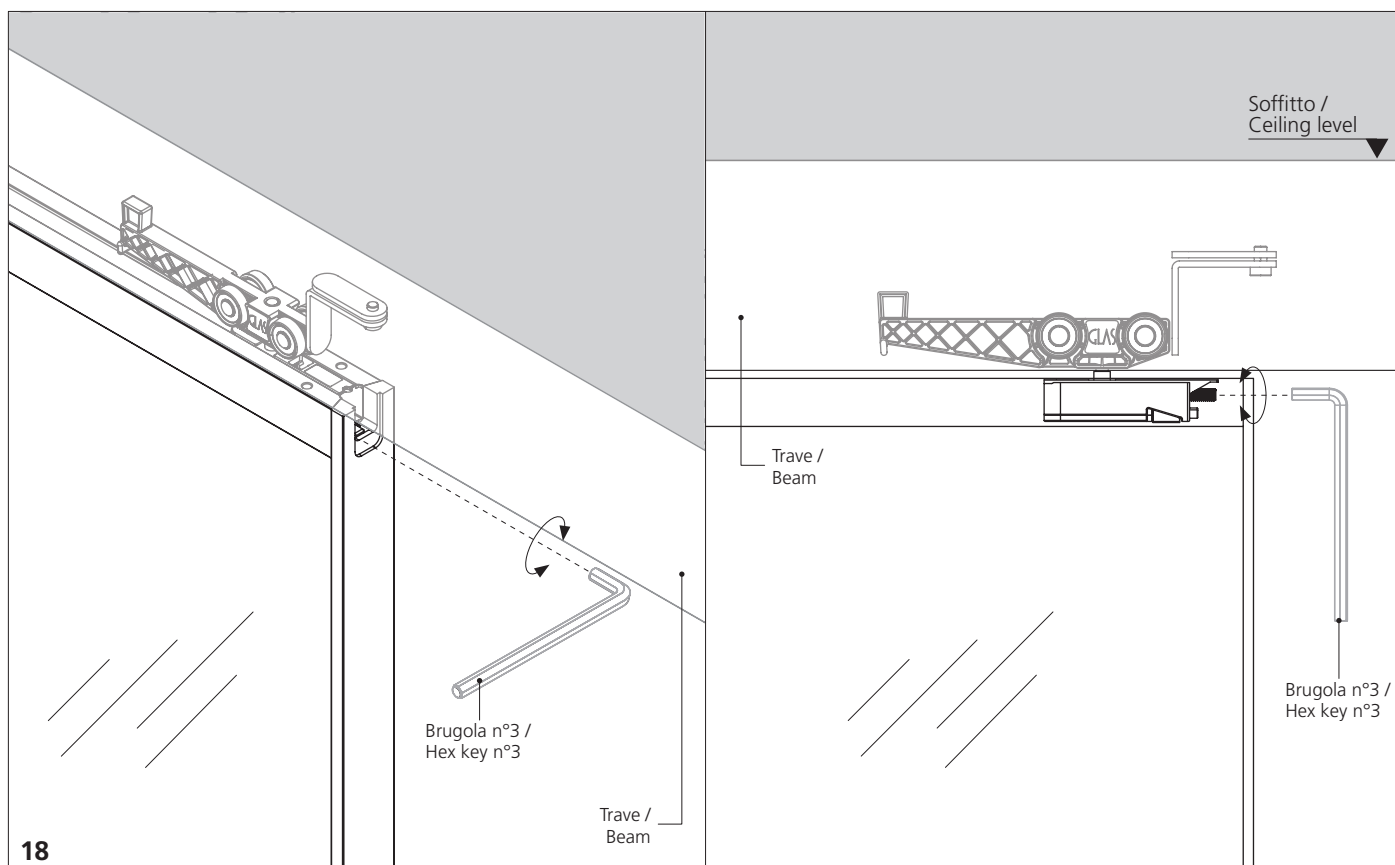

18. Per una regolazione millimetrica dell'anta, agire sulla vite superiore presente nel carrello di scorrimento.
18. To adjust the door millimetrically, act on the upper screw placed in the sliding carriage.

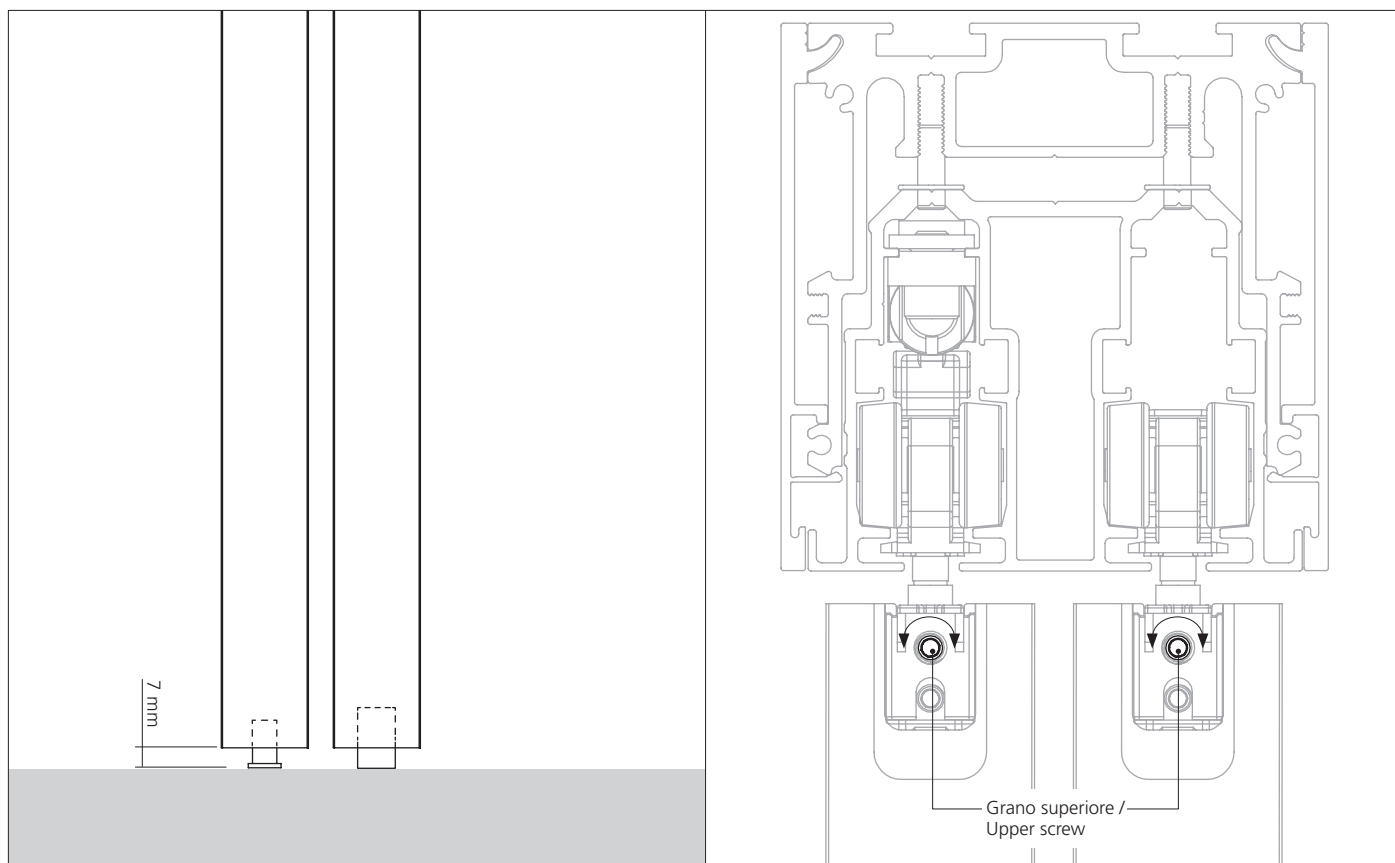

Misura ideale per lo scorrimento dell'anta.
Ideal size for the door's sliding.

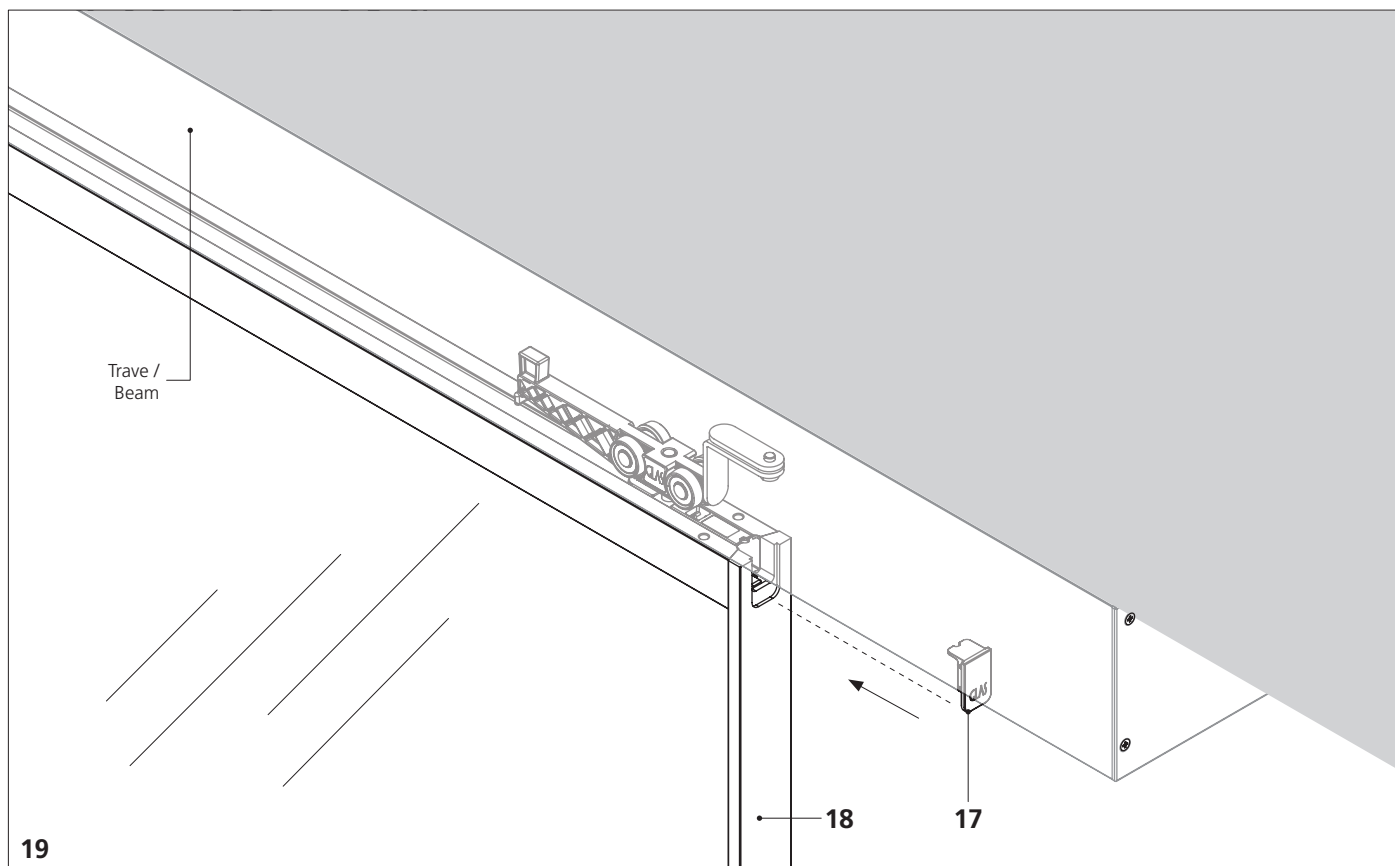

19. Posizionare a pressione il tappo copri carrello sulle ante.
19. Place at pressure the carriage covering cap on doors.